

890 DUKE R

ART. NO. 3214759EN



Congratulations on your decision to purchase a KTM motorcycle. You are now the owner of a state-of-the-art sports vehicle which, with appropriate care, will bring you pleasure for a long time to come.

We wish you good and safe riding at all times!

Enter the serial numbers of your vehicle below.

Vehicle identification number (📖 p. 12)	Dealer's stamp
Engine number (📖 p. 12)	
Key number (📖 p. 12)	

The Owner's Manual contained the latest information for this model series at the time of publication. However, minor differences due to further developments in design cannot be ruled out completely.

All specifications contained herein are non-binding. KTM Sportmotorcycle GmbH specifically reserves the right to modify or delete technical specifications, prices, colors, forms, materials, services, designs, equipment, etc., without prior notice and without specifying reasons, to adapt these to local conditions, as well as to stop production of a particular model without prior notice. KTM accepts no liability for delivery options, deviations from figures and descriptions, misprints, and other errors. The models portrayed partly contain special equipment that does not belong to the regular scope of supply.

© 2023 KTM Sportmotorcycle GmbH, Mattighofen Austria

All rights reserved

Reproduction, even in part, as well as copying of all kinds, is permitted only with the express written permission of the copyright owner.



ISO 9001(12 100 6061)

KTM applies quality assurance processes that lead to the highest possible product quality as defined in the ISO 9001 international quality management standard.

Issued by: TÜV Management Service

REG.NO. 12 100 6061

KTM Sportmotorcycle GmbH
Stallhofnerstraße 3
5230 Mattighofen, Austria

This document is valid for the following models:

890 DUKE R EU (F9703W3)

890 DUKE R ASEAN (F9788W4)

890 DUKE R CN (F9787W4)



3214759en













05.01.2023

TABLE OF CONTENTS

1	MEANS OF REPRESENTATION	5	6.5	Switches on the right side of the handlebar.....	17
1.1	Symbols used	5	6.5.1	Start button/emergency OFF switch.....	17
1.2	Formats used.....	5	6.6	Ignition and steering lock.....	18
2	SAFETY ADVICE.....	6	6.7	Opening fuel tank filler cap.....	18
2.1	Use definition – intended use.....	6	6.8	Closing the fuel tank filler cap.....	19
2.2	Misuse.....	6	6.9	Seat lock.....	19
2.3	Safety advice.....	6	6.10	Tool set.....	20
2.4	Degrees of risk and symbols.....	6	6.11	Grab handle	20
2.5	Tampering warning.....	7	6.12	Passenger foot pegs	20
2.6	Safe operation	7	6.13	Shift lever	21
2.7	Protective clothing	7	6.14	Foot brake lever	21
2.8	Work rules.....	8	6.15	Side stand.....	21
2.9	Environment.....	8	7	COMBINATION INSTRUMENT	22
2.10	Owner's Manual	8	7.1	Combination instrument	22
3	IMPORTANT NOTES.....	9	7.2	Activation and test	22
3.1	Manufacturer warranty, implied warranty.....	9	7.3	Day-Night mode.....	22
3.2	Fuel, auxiliary substances.....	9	7.4	Warnings.....	23
3.3	Spare parts, technical accessories	9	7.5	Indicator lamps.....	23
3.4	Service	9	7.6	Display	25
3.5	Figures	9	7.7	TRACK Display (optional).....	26
3.6	Customer service.....	9	7.8	Heated grip (optional).....	26
4	VIEW OF VEHICLE	10	7.9	Cruise control indicator (optional).....	27
4.1	View of vehicle, front left (example) ...	10	7.10	Fuel level display	27
4.2	View of vehicle, rear right (example).....	11	7.11	Coolant temperature indicator	27
5	SERIAL NUMBERS	12	7.12	trip odometer.....	28
5.1	Vehicle identification number.....	12	7.13	Time.....	28
5.2	Type label	12	7.14	ABS display.....	28
5.3	Key number.....	12	7.15	Shift warning light	28
5.4	Engine number	12	7.16	Menu	29
5.5	Fork part number	13	7.16.1	Favorites.....	29
5.6	Shock absorber article number	13	7.16.2	Trip 1	29
5.7	Steering damper article number	13	7.16.3	Trip 2	30
6	CONTROLS.....	14	7.16.4	General Info	30
6.1	Clutch lever.....	14	7.16.5	Settings	31
6.2	Hand brake lever.....	14	7.16.6	Bluetooth® (optional).....	31
6.3	Throttle grip	14	7.16.7	Distance	31
6.4	Switches on the left side of the handlebar.....	14	7.16.8	Temperature.....	32
6.4.1	Combination switch.....	14	7.16.9	Pressure	32
6.4.2	Light switch	15	7.16.10	Consumption	32
6.4.3	Cruise control system tip switch (optional).....	15	7.16.11	Language	33
6.4.4	Menu buttons.....	17	7.16.12	Clock/Date	33
6.4.5	Turn signal switch.....	17	7.16.13	DRL	33
6.4.6	Horn button	17	7.16.14	TPMS warning	34
			7.16.15	Quick Selector 1	35
			7.16.16	Quick Selector 2	35
			7.16.17	Set Favorites	36
			7.16.18	Heated Grips (optional)	36
			7.16.19	Service	36
			7.16.20	Extra functions	36
			7.16.21	Warnings.....	37
			7.16.22	Ride Mode	37







7.16.23	Track (optional)	38	11.2	Service schedule.....	61
7.16.24	Anti-wheelie mode (optional).....	38	12	TUNING THE CHASSIS	63
7.16.25	Launch control (optional).....	38	12.1	Fork/shock absorber	63
7.16.26	Heated Grips (optional)	39	12.2	Adjusting the compression damping of the fork	63
7.16.27	MTC	39	12.3	Adjusting the rebound damping of the fork.....	63
7.16.28	MTC + MSR (optional).....	39	12.4	Compression damping of the shock absorber.....	64
7.16.29	ABS Mode.....	40	12.5	Adjusting the low-speed compression damping of the shock absorber.....	64
7.16.30	Quickshifter + (optional).....	40	12.6	Adjusting the high-speed compression damping of the shock absorber.....	65
7.16.31	Shift Light	40	12.7	Adjusting the rebound damping of the shock absorber	66
7.16.32	KTM MY RIDE (optional)	41	12.8	Adjusting the spring preload of the shock absorber 🛠.....	66
7.16.33	Pairing (optional)	41	13	SERVICE WORK ON THE CHASSIS.....	68
7.16.34	Audio player (optional)	42	13.1	Raising the motorcycle with the rear lifting gear	68
7.16.35	Telephony (optional)	43	13.2	Removing the rear of the motorcycle from the lifting gear	68
8	ERGONOMICS	44	13.3	Lifting the motorcycle with the front lifting gear	68
8.1	Handlebar position	44	13.4	Taking the motorcycle off the front lifting gear	69
8.2	Adjusting the handlebar position 🛠.....	44	13.5	Cleaning the dust boots of the fork legs 🛠.....	69
8.3	Adjusting the basic position of the clutch lever	45	13.6	Removing the passenger seat	70
8.4	Adjusting the basic position of the hand brake lever	45	13.7	Mounting the passenger seat.....	71
8.5	Adjusting the response of the hand brake lever	45	13.8	Removing the front rider's seat	71
8.6	Adjusting the basic position of the foot brake lever 🛠.....	46	13.9	Mounting the front rider's seat.....	72
8.7	Checking the basic position of the shift lever.....	47	13.10	Checking the chain for dirt.....	72
8.8	Adjusting the basic position of the shift lever 🛠.....	47	13.11	Cleaning the chain	73
9	PREPARING FOR USE.....	48	13.12	Checking the chain tension	73
9.1	Advice on preparing for first use	48	13.13	Adjusting the chain tension.....	74
9.2	Running in the engine	49	13.14	Checking the chain, rear sprocket, engine sprocket, and chain guide	75
9.3	Loading the vehicle	49	14	BRAKE SYSTEM	78
10	RIDING INSTRUCTIONS.....	51	14.1	Anti-lock braking system (ABS)	78
10.1	Checks and maintenance measures when preparing for use	51	14.2	Checking the brake discs	79
10.2	Starting the vehicle	51	14.3	Checking the front brake fluid level ...	79
10.3	Starting off.....	52	14.4	Adding front brake fluid 🛠.....	80
10.4	Launch-Control (optional)	52	14.5	Checking that the brake linings of the front brake are secured	81
10.5	Starting off with launch control (optional)	53	14.6	Checking the free travel of the foot brake lever	82
10.6	Quickshifter + (optional).....	53	14.7	Checking the rear brake fluid level.....	82
10.7	Shifting, riding	54	14.8	Adding rear brake fluid 🛠.....	83
10.8	Engine traction torque control (MSR).....	57	14.9	Checking that the brake linings of the rear brake are secured.....	84
10.9	Applying the brakes.....	57			
10.10	Stopping, parking.....	58			
10.11	Transporting.....	59			
10.12	Towing in the event of a breakdown ...	59			
10.13	Refueling	60			
11	SERVICE SCHEDULE	61			
11.1	Additional information.....	61			

TABLE OF CONTENTS

15	WHEELS, TIRES	85	19.3	Adding engine oil.....	116
15.1	Removing the front wheel 	85	19.4	Checking the free travel of the clutch lever	117
15.2	Installing the front wheel 	86	19.5	Setting the free travel of the clutch lever 	117
15.3	Removing the rear wheel 	87	20	CLEANING, CARE	118
15.4	Installing the rear wheel 	88	20.1	Cleaning the motorcycle	118
15.5	Checking the rear hub damping rubber pieces 	90	20.2	Checks and maintenance steps for winter operation.....	119
15.6	Checking the tire condition	91	21	STORAGE	120
15.7	Checking tire pressure.....	92	21.1	Storage	120
15.8	Using tire repair spray	92	21.2	Preparing for use after storage.....	121
16	ELECTRICAL SYSTEM	94	22	TROUBLESHOOTING	122
16.1	Daytime running light (DRL).....	94	23	TECHNICAL SPECIFICATIONS	124
16.2	Removing the 12-V battery 	94	23.1	Engine	124
16.3	Installing the 12-V battery 	95	23.2	Engine tightening torques	125
16.4	Charging the 12-V battery 	96	23.3	Capacities	127
16.5	Changing the main fuse.....	98	23.3.1	Engine oil	127
16.6	Changing the ABS fuses	99	23.3.2	Coolant.....	127
16.7	Changing the fuses of individual electrical power consumers	100	23.3.3	Fuel	128
16.8	Loosening the headlight mask with the headlight.....	101	23.4	Chassis	128
16.9	Mounting the headlight mask with the headlight	101	23.5	Electrical system.....	129
16.10	Removing the cover of the headlight mask rack	102	23.6	Tires	129
16.11	Installing the cover of the headlight mask rack	103	23.7	Fork.....	129
16.12	Checking the headlight setting	103	23.8	Shock absorber	130
16.13	Adjusting the headlight range.....	104	23.9	Chassis tightening torques	130
16.14	Diagnostics connector	104	24	DECLARATIONS OF CONFORMITY	135
16.15	Front ACC1 and ACC2	105	24.1	Declarations of conformity	135
16.16	ACC1 and ACC2 rear	105	24.2	Country-specific declarations of conformity.....	135
17	COOLING SYSTEM	106	25	SUBSTANCES	136
17.1	Cooling system	106	26	AUXILIARY SUBSTANCES	138
17.2	Checking the antifreeze and coolant level.....	106	27	STANDARDS	139
17.3	Checking the coolant level in the compensating tank.....	107	28	INDEX OF SPECIAL TERMS	140
17.4	Draining the coolant 	108	29	LIST OF ABBREVIATIONS.....	141
17.5	Filling/bleeding the cooling system 	109	30	LIST OF SYMBOLS.....	142
17.6	Changing the coolant.....	110	30.1	Red symbols.....	142
18	TUNING THE ENGINE.....	112	30.2	Yellow and orange symbols.....	142
18.1	Ride Mode	112	30.3	Green and blue symbols.....	142
18.2	Motorcycle traction control (MTC)....	112	INDEX.....		143
18.3	Slip adjustment (optional).....	113			
18.4	Throttle response (optional).....	113			
19	SERVICE WORK ON THE ENGINE	114			
19.1	Checking the engine oil level.....	114			
19.2	Changing the engine oil and oil filter, cleaning the oil screens 	114			

1.1 Symbols used

The meaning of specific symbols is described below.

	Indicates an expected reaction (e.g., of a work step or a function).
	Indicates an unexpected reaction (e.g., of a work step or a function).
	Indicates work that requires expert knowledge and technical understanding. In the interest of your own safety, have these jobs performed by an authorized KTM workshop! Your motorcycle will be cared for there to the highest degree by specially trained experts using the special tools required.
	Indicates a page reference (more information is provided on the specified page).
	Indicates information with more details or tips.
	Indicates the result of a testing step.
	Indicates the end of an activity, including potential reworking.

1.2 Formats used

The typographical formats used in this document are explained below.

Proprietary name	Indicates a proprietary name.
Name[®]	Indicates a protected name.
Brand[™]	Indicates a brand available on the open market.
<u>Underlined terms</u>	Refer to technical details of the vehicle or indicate technical terms, which are explained in the glossary.

2.1 Use definition – intended use

The vehicle is designed and constructed to withstand the usual demands of regular traffic and use on race courses.

This vehicle is not suitable for offroad use.



Info

This vehicle is only authorized for operation on public roads in its homologated version.

2.2 Misuse

The vehicle must only be used as intended.

Dangers can arise for people, property and the environment through use not as intended.

Any use of the vehicle beyond the intended and defined use constitutes misuse.

Misuse also includes the use of operating and auxiliary fluids which do not meet the required specification for the respective use.

2.3 Safety advice

A number of safety instructions need to be followed to operate the product described safely. Therefore read this instruction and all further instructions included carefully. The safety instructions are highlighted in the text and are referred to at the relevant passages.



Info

Various information and warning labels are attached in prominent locations on the product described. Do not remove any information or warning labels. If they are missing, you or others may not recognize dangers and may therefore be injured.

2.4 Degrees of risk and symbols



Danger

Identifies a danger that will immediately and invariably lead to fatal or serious permanent injury if the appropriate measures are not taken.



Warning

Identifies a danger that is likely to lead to fatal or serious injury if the appropriate measures are not taken.



Caution

Identifies a danger that may lead to minor injuries if the appropriate measures are not taken.

Note

Identifies a danger that will lead to considerable machine and material damage if the appropriate measures are not taken.



Note

Indicates a danger that will lead to environmental damage if the appropriate measures are not taken.

2.5 Tampering warning

Tampering with the noise control system is prohibited. Federal law prohibits the following acts or the causing thereof:

- 1 The removal or rendering inoperative by any person other than for purposes of servicing, repair, or replacement, of any device or element of design incorporated into any new vehicle for the purpose of noise control prior to its sale or delivery to the ultimate purchaser or while it is in use, or
- 2 the use of the vehicle after such device or element of design has been removed or rendered inoperative by any person.

Among those acts presumed to constitute tampering are the acts listed below:

- 1 Removal or puncturing of the main silencers, baffles, header pipes or any other components which conduct exhaust gases.
- 2 Removal or puncturing of parts of the intake system.
- 3 Lack of proper maintenance.
- 4 Replacing moving parts of the vehicle, or parts of the exhaust system or intake system, with parts other than those specified by the manufacturer.

2.6 Safe operation



Danger

Danger of accidents A rider who is not fit to ride poses a danger to him or herself and others.

- Do not operate the vehicle if you are not fit to ride due to alcohol, drugs or medication.
- Do not operate the vehicle if you are physically or mentally impaired.



Danger

Danger of poisoning Exhaust gases are toxic and inhaling them may result in unconsciousness and death.

- Always make sure there is sufficient ventilation when running the engine.
- Use effective exhaust extraction when starting or running the engine in an enclosed space.



Warning

Danger of burns Some vehicle components become very hot when the vehicle is operated.

- Do not touch any parts such as the exhaust system, radiator, engine, shock absorber, or brake system before the vehicle parts have cooled down.
- Let the vehicle parts cool down before you perform any work on the vehicle.

Only operate the vehicle when it is in perfect technical condition, in accordance with its intended use, and in a safe and environmentally compatible manner.

An appropriate driver's license is needed to drive the vehicle on public roads.

Have malfunctions that impair safety promptly eliminated by an authorized KTM workshop.

Adhere to the information and warning labels on the vehicle.

2.7 Protective clothing



Warning

Risk of injury Missing or poor protective clothing presents an increased safety risk.

- Wear appropriate protective clothing such as helmet, boots, gloves as well as trousers and a jacket with protectors on all rides.
- Always wear protective clothing that is in good condition and meets the legal regulations.

In the interest of your own safety, KTM recommends that you only operate the vehicle while wearing protective clothing.

2.8 Work rules

Unless specified otherwise, the ignition must be turned off during all work (models with ignition lock, models with remote key) or the engine must be at a standstill (models without ignition lock or remote key).

Special tools are necessary for certain tasks. The tools are not a component of the vehicle, but can be ordered using the number in parentheses. Example: bearing puller (15112017000)

Unless otherwise noted, normal conditions apply to all tasks and descriptions.

Ambient temperature	20 °C (68 °F)
Ambient air pressure	1,013 mbar (14.69 psi)
Relative air humidity	60 ± 5 %

During assembly, use new parts to replace parts which cannot be reused (e.g. self-locking screws and nuts, expansion screws, seals, sealing rings, O-rings, pins, and lock washers).

In the case of certain screws, a screw adhesive (e.g. **Loctite**®) is required. Observe the manufacturer's instructions.

If thread locker (e.g., **Precote**®) has already been applied to a new part, do not apply any additional thread locker. After disassembly, clean the parts that are to be reused and check them for damage and wear. Change damaged or worn parts.

After completing a repair or service work, check the operating safety of the vehicle.

2.9 Environment

If you use your motorcycle responsibly, you can ensure that problems and conflicts do not occur. To protect the future of the motorcycle sport, make sure that you use your motorcycle legally, display environmental consciousness, and respect the rights of others.

When disposing of used oil, other operating and auxiliary fluids, and used components, comply with the laws and regulations of the respective country.

Because motorcycles are not subject to the EU regulations governing the disposal of used vehicles, there are no legal regulations that pertain to the disposal of an end-of-life motorcycle. Your authorized KTM dealer will be glad to advise you.

2.10 Owner's Manual

Read this owner's manual carefully and completely before making your first trip. The Owner's Manual contains useful information and many tips on how to operate, handle, and service your motorcycle. This is the only way to find out how best to customize the vehicle for your own use and how you can protect yourself from injury.



Tip

Store the Owner's Manual on your terminal device, for example, so that you can read it whenever you need to.

If you would like to know more about the vehicle or have questions on the material you read, please contact an authorized KTM dealer.

The Owner's Manual is an important component of the vehicle. If the vehicle is sold, the Owner's Manual must be downloaded again by the new owner.

The Owner's Manual can be downloaded several times using the QR code or the link on the delivery certificate.

The Owner's Manual is also available for download from your authorized KTM dealer and on the KTM website. A printed copy can also be ordered from your authorized KTM dealer.

International KTM Website: KTM.COM

3.1 Manufacturer warranty, implied warranty

The work prescribed in the service schedule must only be carried out in an authorized KTM workshop and confirmed in the **KTM Dealer.net**, as otherwise all warranty claims will be void. Damage or secondary damage caused by tampering with and/or conversions on the vehicle are not covered by the manufacturer warranty.

3.2 Fuel, auxiliary substances



Note

Environmental hazard Improper handling of fuel is a danger to the environment.

- Do not allow fuel to enter the groundwater, the soil, or the sewage system.

Use fuels and auxiliary substances in accordance with the Owner's Manual and specification.

3.3 Spare parts, technical accessories

For your own safety, only use spare parts and accessory products that are approved and/or recommended by KTM and have them installed by an authorized KTM workshop. KTM accepts no liability for other products and any resulting damage or loss.

Certain spare parts and accessory products are specified in parentheses in the descriptions. Your authorized KTM dealer will be glad to advise you.

The latest news **KTM PowerParts** on your vehicle can be found on the KTM website.

International KTM Website: KTM.COM

3.4 Service

A prerequisite for perfect operation and prevention of premature wear is that the service, care, and tuning work on the engine and chassis is properly carried out as described in the Owner's Manual. An incorrect suspension setting can lead to damage and breakage of chassis components.

Use of the vehicle under difficult conditions, such as dusty environments, heavy rain, high heat or with a heavy load, can lead to considerably more rapid wear of components such as the air filter, drive train, brake system, or suspension components. For this reason, it may be necessary to inspect or replace parts before the next scheduled service.

It is imperative that you adhere to the stipulated run-in times and service intervals. If you observe these exactly, you will ensure a much longer service life for your motorcycle.

The relevant mileage or time interval is whichever occurs first.

3.5 Figures

The figures contained in the manual may depict special equipment.

In the interest of clarity, some components may be shown disassembled or may not be shown at all. It is not always necessary to disassemble the component to perform the activity in question. Please follow the instructions in the text.

3.6 Customer service

Your authorized KTM dealer will be happy to answer any questions you may have on your vehicle and KTM.

A list of authorized KTM dealers can be found on the KTM website.

International KTM Website: KTM.COM

4 VIEW OF VEHICLE

4.1 View of vehicle, front left (example)

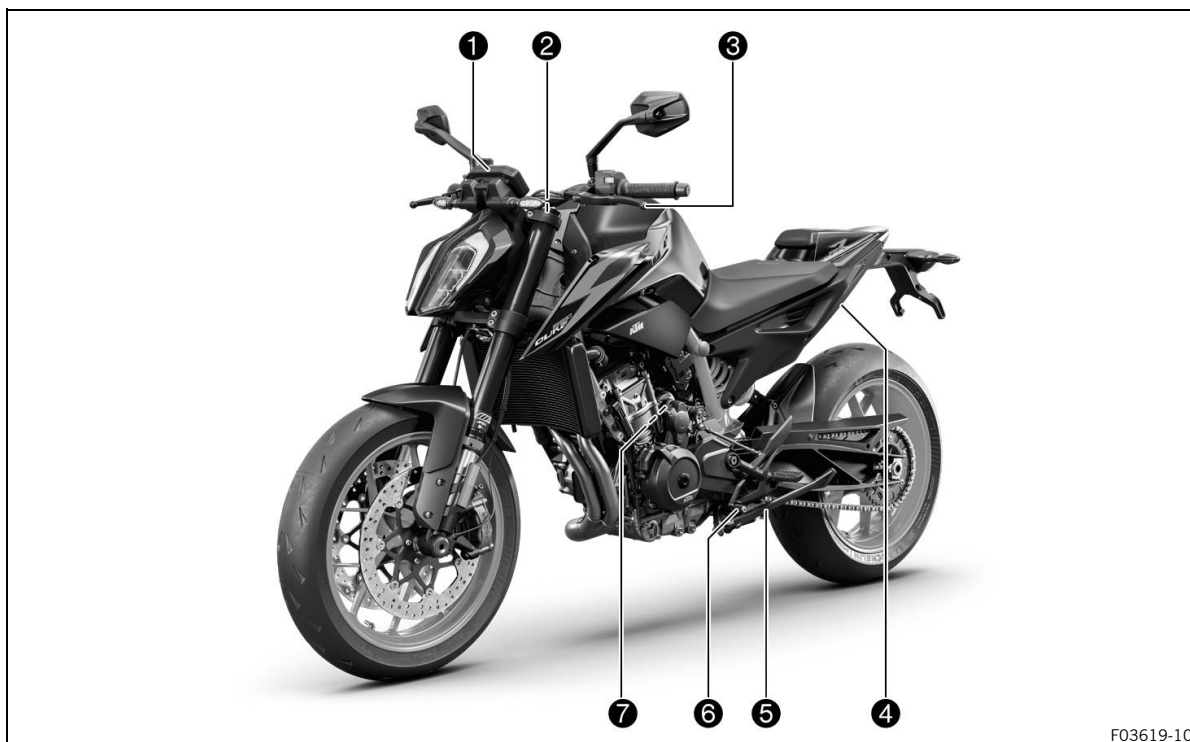

F03619-10

- ❶ Combination instrument (📖 p. 22)
- ❷ Ignition and steering lock (📖 p. 18)
- ❸ Clutch lever (📖 p. 14)
- ❹ Seat lock (📖 p. 19)
- ❺ Side stand (📖 p. 21)
- ❻ Shift lever (📖 p. 21)
- ❼ Engine number (📖 p. 12)

4.2 View of vehicle, rear right (example)

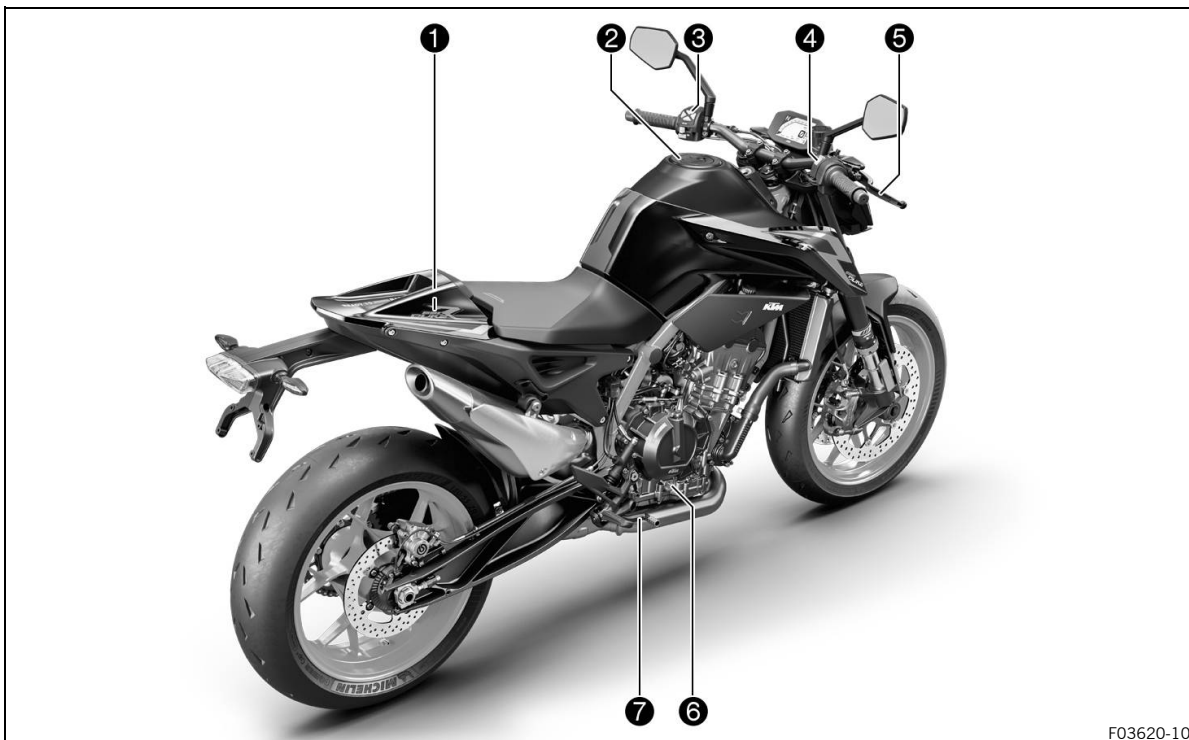

F03620-10

- ❶ Tool set (📖 p. 20)
- ❷ Fuel tank filler cap
- ❸ Combination switch (📖 p. 14)
- ❹ Start button/emergency OFF switch (📖 p. 17)
- ❺ Hand brake lever (📖 p. 14)
- ❻ Level viewer, engine oil
- ❼ Foot brake lever (📖 p. 21)

5 SERIAL NUMBERS

5.1 Vehicle identification number

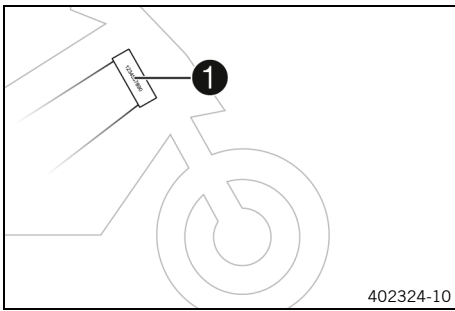

The vehicle identification number **1** is stamped on the right side of the steering head.

5.2 Type label

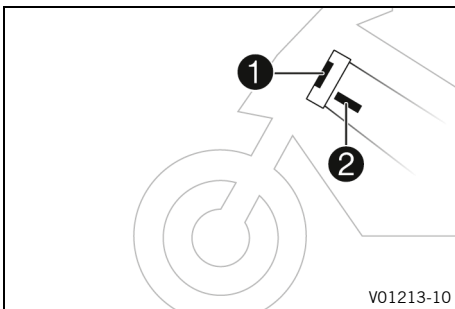

The type label **1** is located on the steering head on the left. The type label Australia **2** is located on the frame behind the steering head at the top left.

5.3 Key number

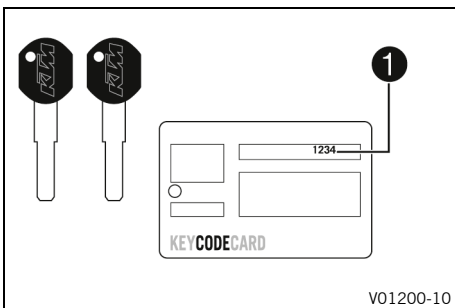

The key number **1** can be found on the **KEYCODECARD**.



Info

You need the key number to order a spare key. Keep the **KEYCODECARD** in a safe place.

5.4 Engine number

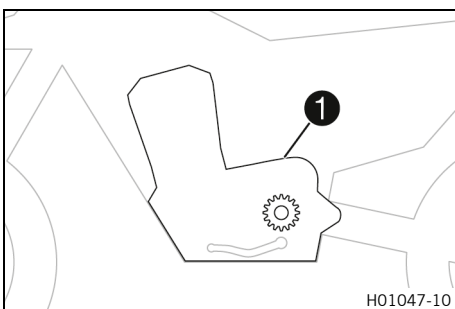

The engine number **1** is stamped onto the engine case at the top.

5.5 Fork part number

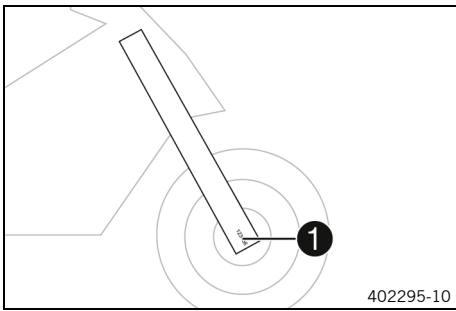

The fork part number **1** is stamped on the inner side of the fork stub.

5.6 Shock absorber article number

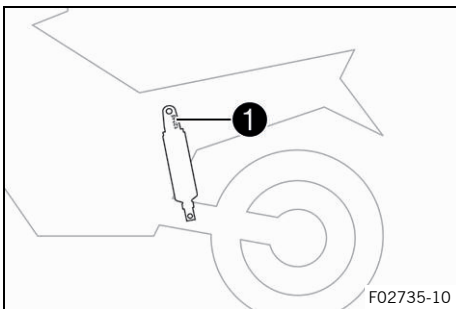

Shock absorber article number **1** is attached the top of the shock absorber.

5.7 Steering damper article number

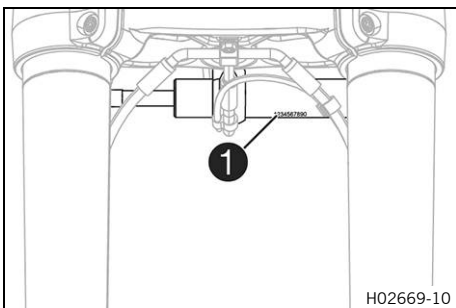

Steering damper article number **1** is embossed on the underside of the steering damper.

6.1 Clutch lever

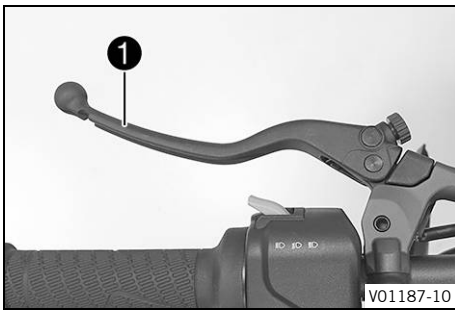

Clutch lever **1** is fitted on the handlebar on the left.

6.2 Hand brake lever



The hand brake lever **1** is located on the right side of the handlebar.

The front brake is engaged using the hand brake lever.

6.3 Throttle grip

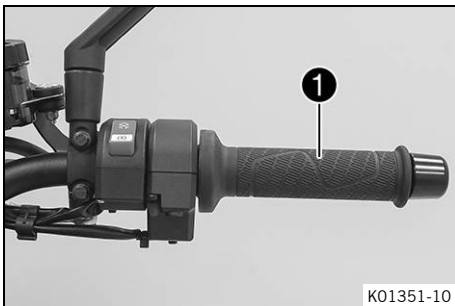

The throttle grip **1** is fitted on the right side of the handlebar.

6.4 Switches on the left side of the handlebar

6.4.1 Combination switch

The combination switch is fitted on the left side of the handlebar.

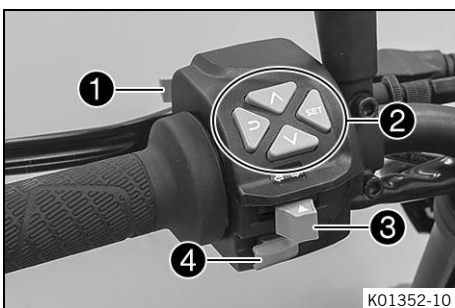

Overview of the left combination switch

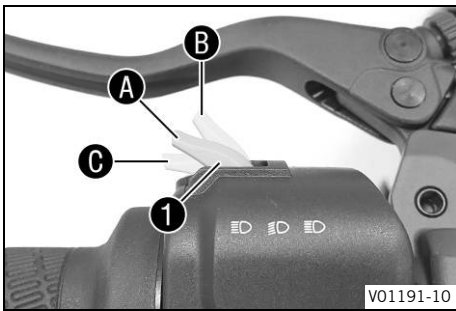

- 1** Light switch (📖 p. 15)
- 2** Menu buttons (📖 p. 17)
- 3** Turn signal switch (📖 p. 17)
- 4** Horn button (📖 p. 17)

6.4.2 Light switch



Light switch 1 is fitted on the left side of the handlebar.

Possible states





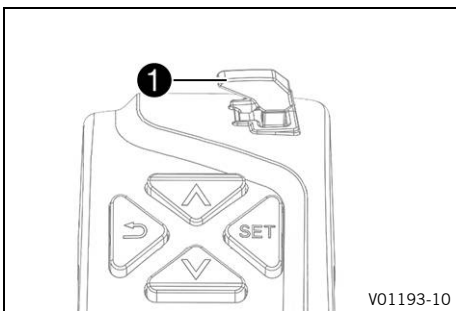



	Low beam on – Light switch in position A. In this position, the low beam and the tail light are switched on.
	High beam on – Push the light switch to position B. In this position, the high beam and the tail light are switched on.
	Headlight flasher – Push the light switch into position C.

6.4.3 Cruise control system tip switch (optional)



The 1 cruise control system tip switch is fitted on the left side of the combination switch.

Possible states

- Cruise control system tip switch  in the basic position.
- Cruise control system tip switch  pressed to the left. – In this position, the cruise control system function is switched on and off. The operating mode is displayed in the combination instrument.
- Briefly press cruise control system tip switch  in position **RES/+**. – In this position, the cruise control system function is activated for the first time if no speed was saved beforehand. The operating mode is displayed in the combination instrument.
- Briefly press cruise control system tip switch  in position **SET/-**. – In this position, the cruise control system function is activated for the first time if no speed was saved beforehand. The operating mode is displayed in the combination instrument.
- Briefly press cruise control system tip switch  in position **RES/+**. – The last saved speed is reapplied. Every subsequent brief pressing increases the target speed by 1 km/h or 1 mph.
- Press and hold the cruise control system tip switch  in position **RES/+**. – The target speed increases in increments of 5 km/h or 5 mph.
- Briefly press cruise control system tip switch  in position **SET/-**. – The cruise control system function is activated and the current speed is maintained. Every subsequent brief press reduces the target speed by 1 km/h or 1 mph.
- Press and hold the cruise control system tip switch  in position **SET/-**. – The target speed decreases in increments of 5 km/h or 5 mph.

i Info

After activation of the cruise control system function, the throttle grip can be turned back to the basic position. The selected speed will be maintained.

If the target speed is exceeded for less than 30 seconds by turning the throttle grip, the cruise control system remains activated.

To switch off the cruise control system function, press the cruise control system tip switch  to the left.

In addition, the cruise control system function is deactivated when one of the following events occurs:

- Operating the hand brake lever
- Operating the foot brake lever
- Operating the clutch lever
- Turning the throttle grip beyond the basic position
- Control of the motorcycle traction control (**MTC**)
- Slip at the rear wheel or lifting front wheel
- A fault occurring, which impairs the cruise control system function
- Exceeding the target speed for more than 30 seconds when overtaking



Warning

Danger of accidents The cruise control system function is not suitable for all riding situations.

The selected target speed will not be reached, if the engine power is not sufficient for a gradient.

The selected target speed will be exceeded if the engine braking effect is not sufficient on an incline.

- Do not use the cruise control systems function on winding roads.
- Do not use the cruise control systems on slippery road surfaces (e.g. rain, ice or snow), where there is poor visibility or on unpaved surfaces (e.g. sand, stones or gravel).
- Do not use the cruise control systems function if the traffic does not permit a constant speed.

The cruise control system function is only available when motorcycle traction control (**MTC**) is activated.

When motorcycle traction control (**MTC**) is switched off, the cruise control system function is also switched off.

With the cruise control system function active, menu items **Ride Mode**, **Throttle response**, and **Leave Track** are not available. The cruise control system function cannot be activated during rapid acceleration.

The cruise control system function can only be activated in 2nd, 3rd, 4th, 5th and 6th gear.

The control range is from 30 to 160 km/h or from 18 to 100 mph.

6.4.4 Menu buttons

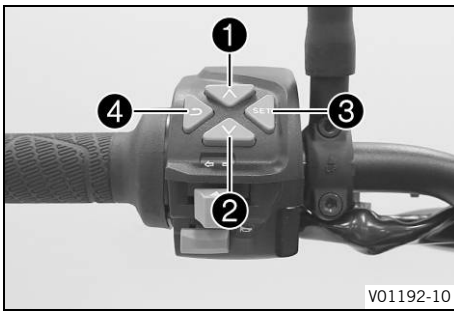

The menu buttons are fitted in the middle of the left combination switch.

The menu buttons are used to control the display on the combination instrument.

Button **1** is the **UP** button.

Button **2** is the **DOWN** button.

Button **3** is the **SET** button.

Button **4** is the **BACK** button.

6.4.5 Turn signal switch

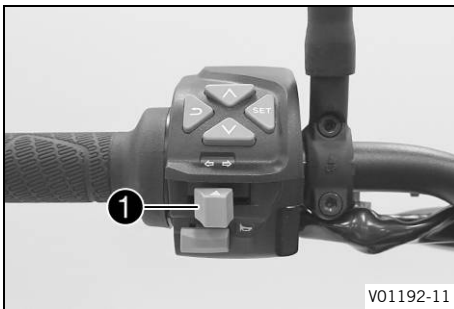

The turn signal switch **1** is fitted on the left side of the handlebar.

Possible states

	Turn signal off
	Left turn signal on – Turn signal switch pressed to the left. The turn signal switch returns to the center position after activation.
	Right turn signal on – Turn signal switch pressed to the right. The turn signal switch returns to the center position after activation.

To switch off the turn signal, press the turn signal switch towards the switch housing.

6.4.6 Horn button

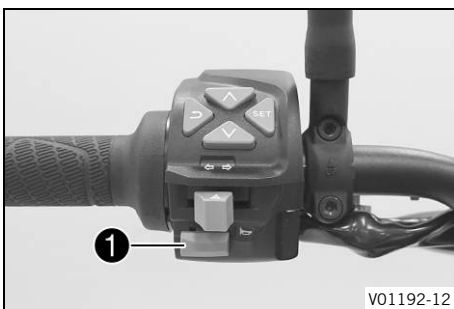

Horn button **1** is fitted on the left side of the handlebar.

Possible states

- The horn button is in the basic position
- The horn button is pressed – The horn is operated in this position.

6.5 Switches on the right side of the handlebar

6.5.1 Start button/emergency OFF switch



The start button/emergency OFF switch **1** is fitted on the right side of the combination switch.

Possible states

	Start button/emergency OFF switch off (upper position) – In this position, the ignition circuit is interrupted, a running engine stops, and a non-running engine cannot be started. A message appears on the display.
	Start button/emergency OFF switch on (middle position) – This position is required for operation; the ignition circuit is closed.

	Starter motor on (lower position) – In this position, the starter motor is actuated.
---	--



6.6 Ignition and steering lock



K01354-01

The ignition and steering lock is located in front of the upper triple clamp.

Possible states

	Ignition off – In this position, the ignition circuit is interrupted, a running engine stops, and a non-running engine will not start. The ignition key can be removed.
	Ignition on – In this position, the ignition circuit is closed and the engine can be started.
	Steering locked – In this position, the ignition circuit is interrupted and the steering locked. The ignition key can be removed.

6.7 Opening fuel tank filler cap



Danger

Fire hazard Fuel is highly flammable.

The fuel in the fuel tank expands when warm and can escape if overfilled.

- Do not fuel the vehicle in the vicinity of open flames or lit cigarettes.
- Switch off the engine for refueling.
- Make sure that no fuel is spilled; particularly not on hot parts of the vehicle.
- If any fuel is spilled, wipe it off immediately.
- Observe the specifications for refueling.



Warning

Danger of poisoning Fuel is harmful to health.

- Avoid skin, eye and clothing contact with fuel.
- Immediately consult a doctor if you swallow fuel.
- Do not inhale fuel vapors.
- Rinse the affected area immediately with plenty of water in the event of contact with the skin.
- Rinse the eyes thoroughly with water, and consult a doctor in case of fuel contact with the eyes.
- Change your clothing if fuel spills on them.
- Keep fuels correctly in a suitable canister, and out of the reach of children.



Note

Environmental hazard Improper handling of fuel is a danger to the environment.

- Do not allow fuel to enter the groundwater, the soil, or the sewage system.

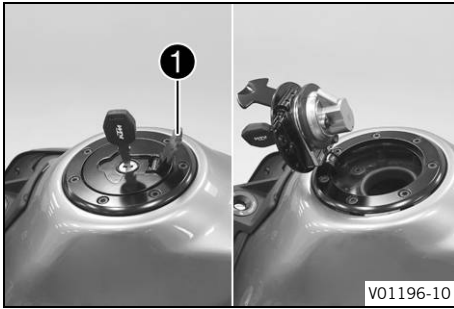

- Lift cover **1** of the fuel tank filler cap and insert the ignition key into the lock.

Note

Danger of damage The ignition key may break if overloaded. Damaged ignition keys must be replaced.

- Push down on the fuel tank filler cap to take pressure off the ignition key.
- Turn the ignition key 90° clockwise.
- Lift the fuel tank filler cap.



6.8 Closing the fuel tank filler cap



- Fold down the fuel tank filler cap.
- Turn the ignition key 90° clockwise.
- Push down the fuel tank filler cap and turn the ignition key counterclockwise until the lock closes.



Warning

Fire hazard Fuel is highly flammable and a health hazard.

- Check that the fuel tank filler cap is locked correctly after closing.
- Change your clothing if fuel spills on them.
- Rinse the affected area immediately with plenty of water in the event of contact with the skin.

- Remove the ignition key and close the cover.



6.9 Seat lock



The seat lock **1** is located on the left side of the vehicle. It can be locked with the ignition key.

6.10 Tool set

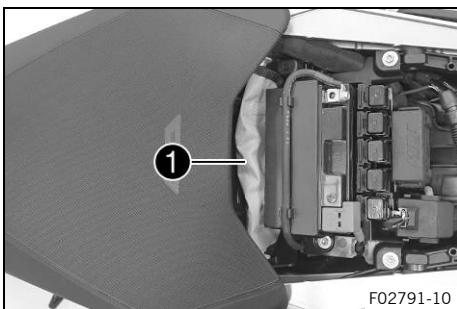

The tool set ① is located under the passenger seat.

6.11 Grab handle

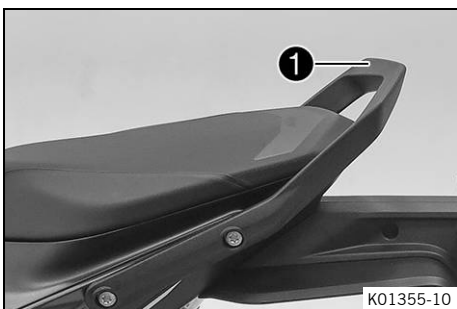

The grab handle ① is used for maneuvering the motorcycle. If you carry a passenger, the passenger can hold onto the grab handles during the trip.

i Info

The vehicle has been set up in the factory for one-person operation. Only an authorized KTM workshop may carry out the conversion.

The components for one-person operation and for operation with a passenger are included in the scope of supply.

Always ensure that the legal requirements are observed, e.g., entry in the vehicle documents if applicable.

6.12 Passenger foot pegs

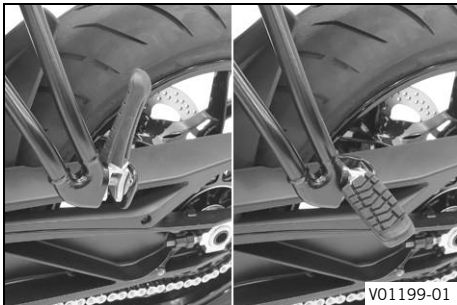

The passenger foot pegs can be folded up and down.

i Info

The vehicle has been set up in the factory for one-person operation. Only an authorized KTM workshop may carry out the conversion.

The components for one-person operation and for operation with a passenger are included in the scope of supply.

Always ensure that the legal requirements are observed, e.g., entry in the vehicle documents if applicable.

Possible states

- Passenger foot pegs folded up – For operation without a passenger.
- Passenger foot pegs folded down – For operation with a passenger.

6.13 Shift lever

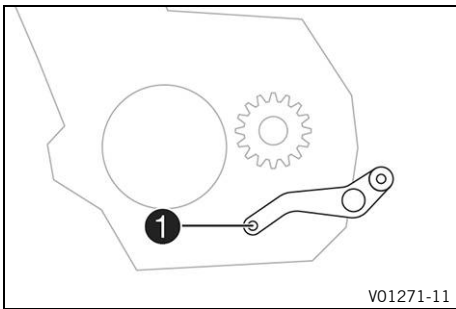

The shift lever ① is mounted on the left side of the engine.

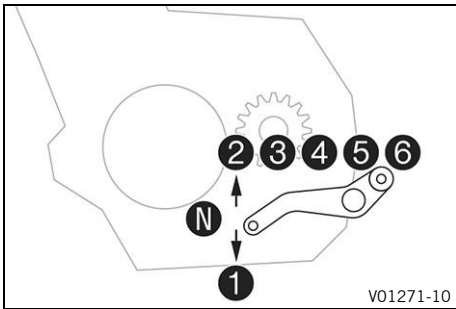

The gear positions can be seen in the photograph.
The neutral or idle position is between the first and second gears.

6.14 Foot brake lever

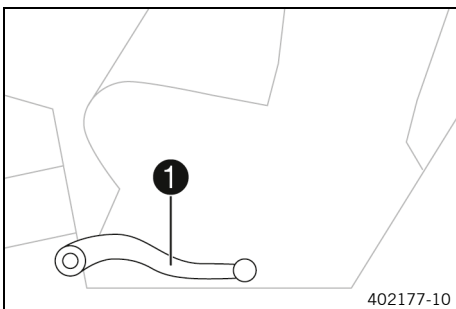

Foot brake lever ① is located in front of the right footrest.
The rear brake is engaged with the foot brake lever.

6.15 Side stand

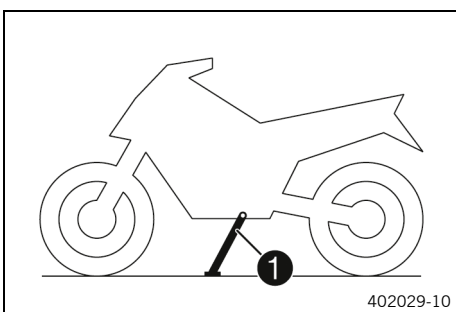

The side stand ① is located on the left of the vehicle.
The side stand is used for parking the motorcycle.



Info

The side stand must be folded up during motorcycle use.
The side stand is coupled with the safety starting system;
follow the riding instructions.

Possible states

- Side stand folded out – The vehicle can be supported on the side stand. The safety starting system is active.
- Side stand folded in – This position is mandatory when riding the motorcycle. The safety starting system is inactive.

7.1 Combination instrument

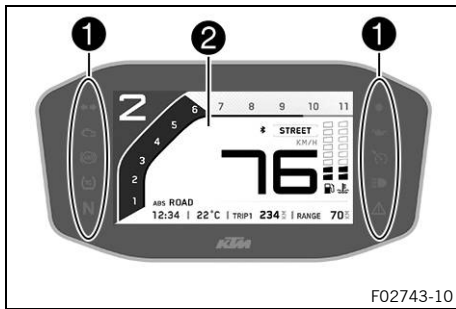

The combination instrument is attached in front of the handlebar. The combination instrument is divided into two function areas.

① indicator lamps (📖 p. 23)

Display ②

7.2 Activation and test



Activation

The combination instrument is activated when the ignition is switched on.



Info

The brightness of the displays is controlled by an ambient light sensor in the combination instrument.

Test

The welcome text appears on the display and the indicator lamps are briefly activated for a function check.



Info

The malfunction indicator lamp always lights up as long as the engine is not running. If the engine is running and the malfunction indicator lamp lights up, stop (taking care not to endanger yourself or other road users in the process) and contact an authorized KTM workshop.

The oil pressure warning lamp always lights up as long as the engine is not running. If the engine is running and the oil pressure warning lamp lights up, stop immediately (taking care not to endanger yourself or other road users in the process) and switch off the engine.

The ABS warning lamp and TC indicator lamp light up until a speed of approx. 6 km/h (approx. 4 mph) or more has been reached.

7.3 Day-Night mode

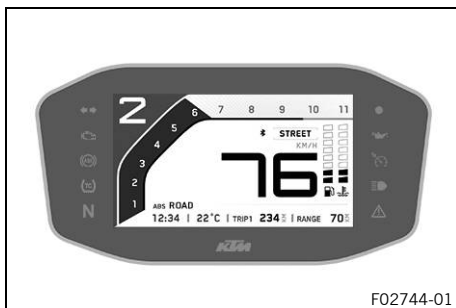

Day mode is shown in a bright color.

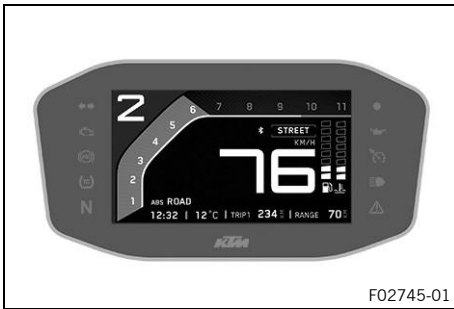

F02745-01

Night mode is shown in a dark color.

i Info

The ambient light sensor in the combination instrument measures the brightness of the environment and automatically switches the display to day or night mode. The display is brightened, darkened or switched to the other mode depending on the brightness measured by the ambient light sensor.

The display mode cannot be changed manually.

7.4 Warnings

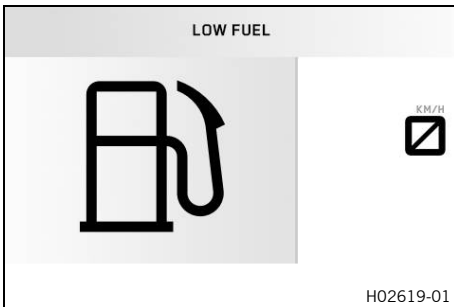

H02619-01

If the general warning lamp  lights up among the indicator lamps (p. 23), the corresponding message appears in the display. Pressing any button confirms receipt of the information and the message is cleared.

All the existing warnings are displayed in the **Warnings** menu until they are no longer active.

7.5 Indicator lamps



F02746-01

The indicator lamps offer additional information about the operating state of the motorcycle. When the ignition is switched on, all indicator lamps light up briefly.











i Info

The malfunction indicator lamp always lights up as long as the engine is not running. If the engine is running and the malfunction indicator lamp lights up, stop (taking care not to endanger yourself or other road users in the process) and contact an authorized KTM workshop.

The oil pressure warning lamp always lights up as long as the engine is not running. If the engine is running and the oil pressure warning lamp lights up, stop immediately (taking care not to endanger yourself or other road users in the process) and switch off the engine.

The ABS warning lamp and TC indicator lamp light up until a speed of approx. 6 km/h (approx. 4 mph) or more has been reached.

Possible states

	The turn signal indicator lamp flashes green simultaneously with the turn signal – The turn signal is switched on.
	Malfunction indicator lamp lights up yellow – The <u>OBD</u> has detected a malfunction in the vehicle electronics. Come safely to a halt, and contact an authorized KTM workshop.
	ABS warning lamp lights up yellow – Status or error messages relating to <u>ABS</u> .
	TC indicator lamp lights up yellow – MTC (📖 p. 112) is not enabled or is currently intervening. The TC indicator lamp also lights up if a malfunction is detected. Contact an authorized KTM workshop. The TC indicator lamp flashes if MTC actively engages or if the Launch Control (📖 p. 52) is activated.
	The idle indicator lamp lights up green – The transmission is in neutral.
	The immobilizer indicator lamp lights up or flashes red – Status or error message of the alarm system.
	The oil pressure warning lamp lights up red – The oil pressure is too low. Stop immediately, taking care not to endanger yourself or other road users in the process, and switch off the engine.
	The cruise control system indicator lamp (optional) lights up yellow – The cruise control system function is switched on, but cruise control is not activated.
	The cruise control system indicator lamp (optional) lights up green – The cruise control system function is switched on and cruise control is activated.
	The high beam indicator lamp lights up blue – The high beam is switched on.
	The general warning lamp lights up yellow – A note/warning on operating safety has been detected. This is also shown in the display.

7.6 Display

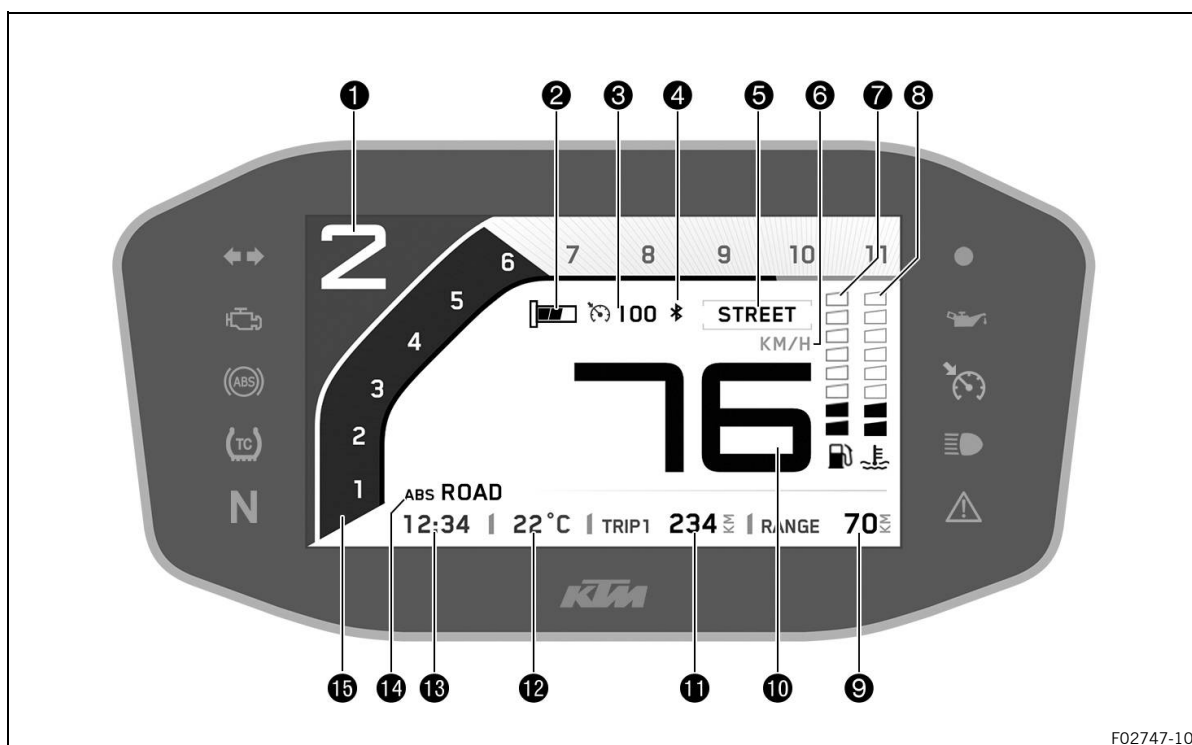

F02747-10

**Info**

The figure shows the start screen of the combination instrument. If the menu is opened, the speed is still displayed.

- 1 Gear display
 - 2 Heated grip (optional) (📖 p. 26)
 - 3 Cruise control indicator (optional) (📖 p. 27)
 - 4 **Bluetooth®** (optional)
 - 5 **Ride Mode** (📖 p. 112)
 - 6 Unit for the speedometer
 - 7 Fuel level display (📖 p. 27)
 - 8 Coolant temperature indicator (📖 p. 27)
 - 9 Range display
 - 10 Speed
 - 11 trip odometer (📖 p. 28)
 - 12 Ambient temperature
 - 13 Time (📖 p. 28)
 - 14 **ABS** display (📖 p. 28)
 - 15 Tachometer
- Shift warning light (📖 p. 28)
The shift warning light is integrated in the tachometer display.

7.7 TRACK Display (optional)

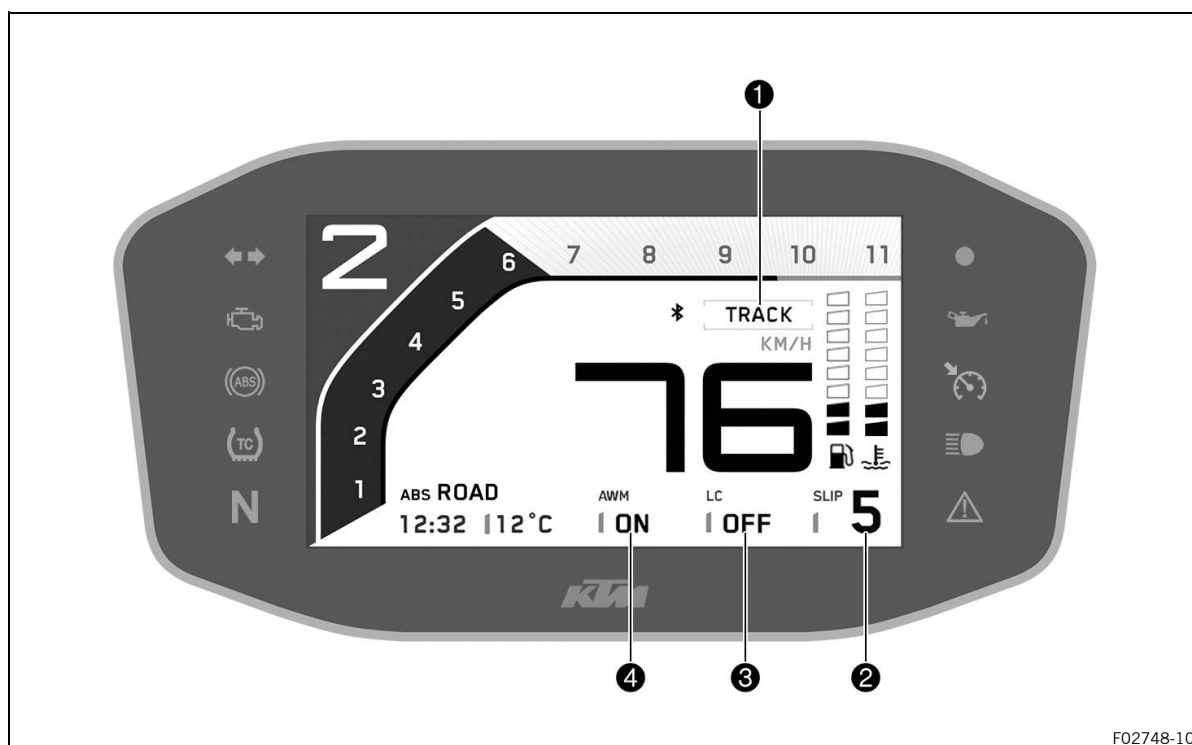

F02748-10

i Info

The figure shows the start screen of the combination instrument in active riding mode **TRACK** (optional). If the menu is opened, the speed is still displayed.

- ❶ **Throttle response** (optional) (📖 p. 113)
- ❷ Slip adjustment (optional) (📖 p. 113)
- ❸ **Launch-Control** (optional) (📖 p. 52)
- ❹ Anti Wheelie Mode (optional)

7.8 Heated grip (optional)

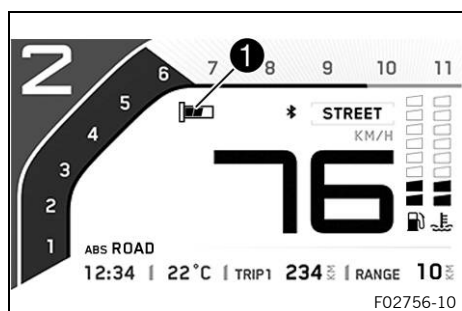

F02756-10

When the heated grip (optional) is switched on, the **Heated Grips** symbol appears in the ❶ area of the display. The heated grip can be configured in the **Heated Grips** menu.

7.9 Cruise control indicator (optional)

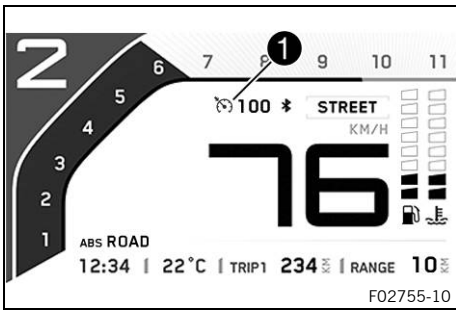

When cruise control (optional) is activated, the operating mode **1** is shown on the combination instrument display. Cruise control is operated using the cruise control tip switch (p. 15).

7.10 Fuel level display

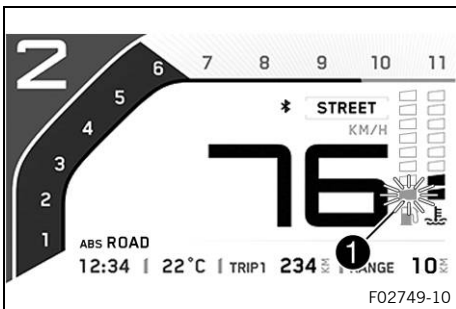

The fuel level indicator **1** consists of bars. The more bars are lit, the more fuel is in the fuel tank.

i Info

If the fuel level is getting low, the last bar flashes orange and the **LOW FUEL** warning also appears. The fuel level is displayed with a slight delay to prevent the indicator from constantly moving while riding. The fuel level display is not updated while the side stand is folded out or the emergency off switch is switched off. Once the side stand is folded up and the emergency OFF switch is switched on, the fuel level display is next updated after 2 minutes. The fuel level display flashes if the combination instrument does not receive a signal from the fuel level sensor.

7.11 Coolant temperature indicator

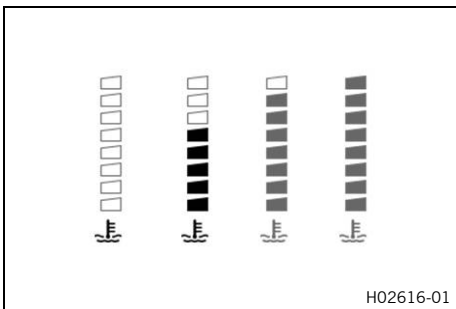

Note

Engine failure Overheating damages the engine.

- If the coolant temperature warning is displayed, stop immediately and take care not to endanger yourself or other traffic participants in the process.
- Allow the engine and cooling system to cool down.
- Check and, if necessary, correct the coolant level on the cooling system while it is in a cooled state.

The temperature indicator consists of eight bars. The more bars that light up, the hotter the coolant. Emergency mode operation is automatically activated at a coolant temperature of 120 °C.

i Info

When all the bars light up, the **ENGINE TEMP HIGH** warning also appears.

Possible states

- The engine is cold – Up to three bars light up.
- Engine warm – Four to five bars light up.
- Engine hot – Six to eight bars light up.

- Engine very hot – All eight bars flash orange.

7.12 trip odometer

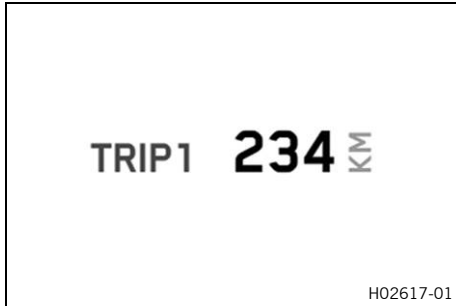

Trip 1 is displayed in the start screen as a trip odometer. This cannot be changed.

Information about the total riding distance covered can be accessed in the **General Info** menu under menu item **Odometer**.

The trip odometer can be configured in the **Trip 1** menu.

Information about other distances traveled can be accessed and configured in the **Trip 2** menu.

7.13 Time

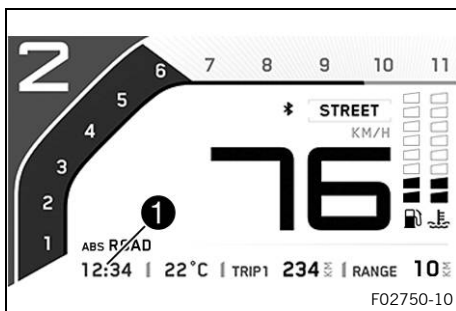

The time **1** is displayed in 24 hour format in all languages except for EN-US. The time **1** is displayed in 12 hour format if the language is set to EN-US.

The time can be configured in the **Clock/Date** menu.

i Info

The time must be reset if the 12-V battery was disconnected from the vehicle or the fuse was removed.

7.14 ABS display

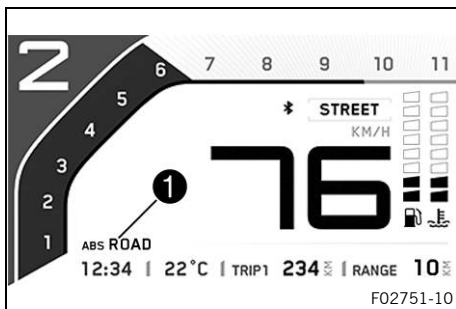

The ABS mode setting is shown in the **1** area of the display. The **ABS** can be configured in the **ABS Mode** menu.

7.15 Shift warning light

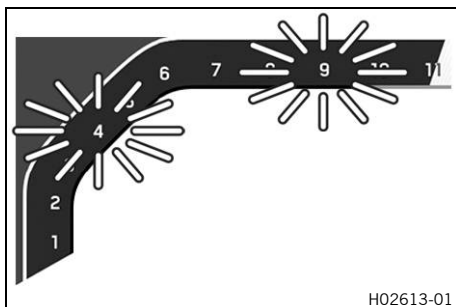

The shift warning light is integrated in the tachometer display.

The speed for the shift warning light can be set in the **Shift Light** menu. The shift warning light is always active during the running-in time (up to 1,000 km / 600 mi). The shift warning light can only be deactivated, and the values for **Lights up** and **Flashes** can only be adjusted after this. The shift warning light lights up orange at **Lights up** and flashes orange at **Flashes**.

Coolant temperature	> 35 °C (> 95 °F)
Lights up	Shift warning light lights up orange
Flashes	Shift warning light flashes orange
Coolant temperature	≤ 35 °C (≤ 95 °F)

The shift warning light always lights up at	6,500 rpm
---	-----------

7.16 Menu

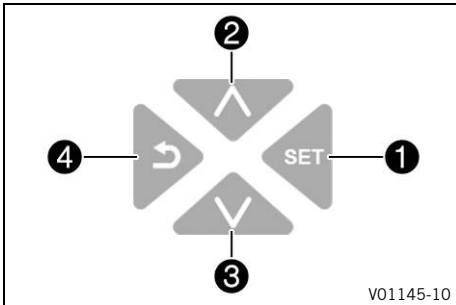

i Info
 Press the **SET** button **1** to open the menu. Navigate through the menu using the **UP** button **2** or the **DOWN** button **3**. Press the **BACK** button **4** to close the current menu or the menu overview.

7.16.1 Favorites

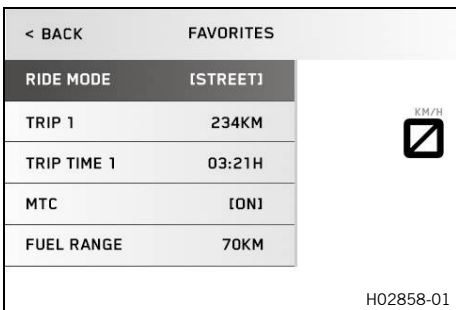

- Press the **SET** button when the menu is closed.
 - Pressing the **SET** button again opens the menu.
 - Press the **UP** or **DOWN** button to activate the menu item and select it with the **SET** button.
- You can directly open five freely configurable menus in the **Favorites** menu. The **Favorites** menu is configured in the **Set Favorites** menu.

7.16.2 Trip 1

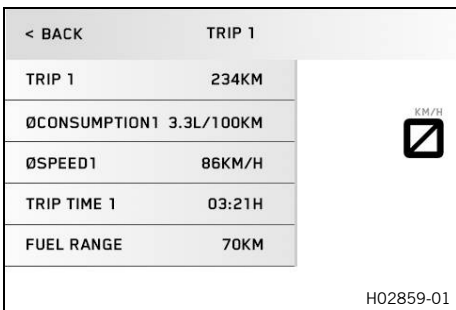

- Press the **SET** button when the menu is closed.
 - Press the **UP** or **DOWN** button until the **Trips/Data** menu is marked on the display. Press the **SET** button to open the menu.
 - Press the **UP** or **DOWN** button until the **Trip 1** menu is marked on the display. Press the **SET** button to open the menu.
- Trip 1** shows the distance since the last reset, such as between two refueling stops. **Trip 1** is running and counts up to **9999**. **ØConsumption1** indicates the average fuel consumption based on **Trip 1** and **Trip time 1**. **ØSpeed1** indicates the average speed based on **Trip 1** and **Trip time 1**. **Trip time 1** shows the journey time on the basis of **Trip 1** and runs as soon as a speed signal is received. **Fuel range** indicates the possible distance you can cover with the fuel reserve.

Press and hold the button SET for 3–5 seconds.	In the Trip 1 menu all entries apart from Fuel range are deleted.
--	---

7.16.3 Trip 2

< BACK	TRIP 2	
TRIP 2	678KM	
ØCONSUMPTION2	3.7L/100KM	
ØSPEED2	93KM/H	
TRIP TIME 2	07:56H	
FUEL RANGE	70KM	

H02857-01

- Press the **SET** button when the menu is closed.
- Press the **UP** or **DOWN** button until the **Trips/Data** menu is marked on the display. Press the **SET** button to open the menu.
- Press the **UP** or **DOWN** button until the **Trip 2** menu is marked on the display. Press the **SET** button to open the menu.

Trip 2 shows the distance since the last reset, such as between two refueling stops. **Trip 2** is running and counts up to **9999**.

ØConsumption2 indicates the average consumption based on **Trip 2** and **Trip time 2**.

ØSpeed2 indicates the average speed based on **Trip 2** and **Trip time 2**.

Trip time 2 shows the journey time on the basis of **Trip 2** and runs as soon as a speed signal is received.

Fuel range indicates the possible distance you can cover with the fuel reserve.

Press and hold the button **SET** for 3–5 seconds.

In the **Trip 2** menu all entries apart from **Fuel range** are deleted.

7.16.4 General Info

< BACK	GENERAL INFO	
DATE	12.01.2018	
ODOMETER	1234KM	
BATTERY	12.0V	
TYRE PRESS FRON	2.3	
TYRE PRESS REAR	2.6	

V01111-01



Warning

Danger of accidents The tire pressure monitoring system does not eliminate the necessity to check the tires before going on a ride.

To avoid false alarms, the tire pressure values are evaluated over a period of several minutes.

- Check the tire pressure before every ride.
- Correct the tire pressure if the tire pressure deviates from the specified value.
- Even if the tire pressure values are correct, stop the vehicle immediately if its behavior indicates a loss of pressure in the tires.

- Press the **SET** button when the menu is closed.
- Press the **UP** or **DOWN** button until the **Trips/Data** menu is marked on the display. Press the **SET** button to open the menu.
- Press the **UP** or **DOWN** button until the **General Info** menu is marked on the display. Press the **SET** button to open the menu.

Date shows the date.

Odometer shows the total distance covered.

Battery indicates the battery voltage.

Tire press fron (optional) indicates the tire pressure at the front.

Tire press rear (optional) indicates the tire pressure at the rear.

7.16.5 Settings

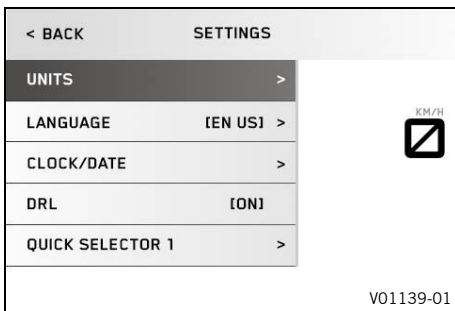

Condition

- The motorcycle is stationary.
- Press the **SET** button when the menu is closed.
- Press the **UP** or **DOWN** button until the **Trips/Data** menu is marked on the display. Press the **SET** button to open the menu.
- Press the **UP** or **DOWN** button until the **Settings** menu is marked on the display. Press the **SET** button to open the menu.

Settings for units or various values are made in the **Settings** menu. Several functions can be enabled or disabled.

7.16.6 Bluetooth® (optional)

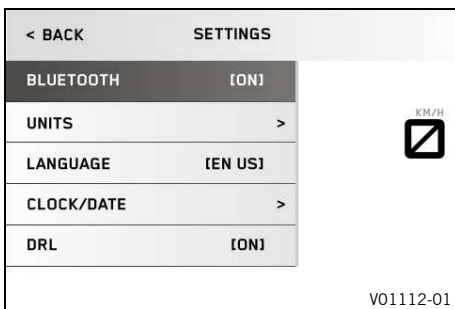

Condition

- The motorcycle is stationary.
- Function **KTM MY RIDE** (optional) activated.
- Press the **SET** button when the menu is closed.
- Press the **UP** or **DOWN** button until the **Trips/Data** menu is marked on the display. Press the **SET** button to open the menu.
- Press the **UP** or **DOWN** button until the **Settings** menu is marked on the display. Press the **SET** button to open the menu.
- Press the **UP** or **DOWN** button until **Bluetooth®** is marked on the display.
- Switch the **Bluetooth®** on and off using the **SET** button.

Info

The **Bluetooth®** function can only be used in conjunction with **KTM MY RIDE** (optional).
If a device has been paired via the menu **Pairing** but is currently not connected, the **Bluetooth®** symbol flashes when the **Bluetooth®** function is switched on. The **Bluetooth®** symbol lights up as soon as a device is connected.

7.16.7 Distance

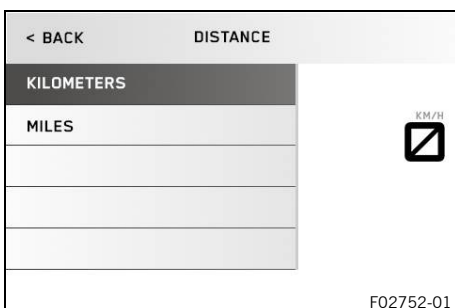

Condition

- The motorcycle is stationary.
- Press the **SET** button when the menu is closed.
- Press the **UP** or **DOWN** button until the **Trips/Data** menu is marked on the display. Press the **SET** button to open the menu.
- Press the **UP** or **DOWN** button until the **Settings** menu is marked on the display. Press the **SET** button to open the menu.
- Press the **UP** or **DOWN** button until **Units** is marked on the display. Pressing the **SET** button again opens the menu.
- Press the **UP** or **DOWN** button until **Distance** is marked on the display. Pressing the **SET** button again sets the unit of measure.

Select kilometers **km** or miles **mi** for the distance.

7.16.8 Temperature

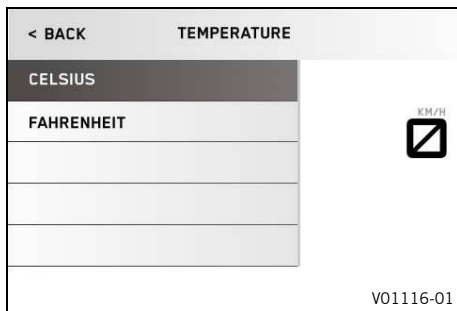

Condition

- The motorcycle is stationary.
- Press the **SET** button when the menu is closed.
- Press the **UP** or **DOWN** button until the **Trips/Data** menu is marked on the display. Press the **SET** button to open the menu.
- Press the **UP** or **DOWN** button until the **Settings** menu is marked on the display. Press the **SET** button to open the menu.
- Press the **UP** or **DOWN** button until **Units** is marked on the display. Pressing the **SET** button again opens the menu.
- Press the **UP** or **DOWN** button until **Temperature** is marked on the display. Pressing the **SET** button again sets the unit of measure.

Select **°C** or **°F** for the temperature indicator.

7.16.9 Pressure

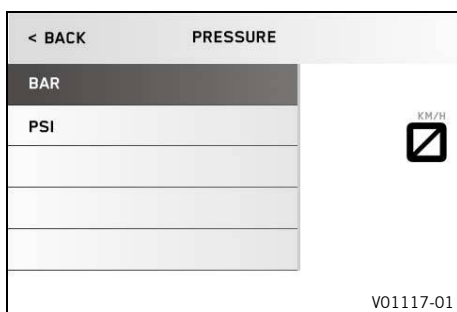

Condition

- The motorcycle is stationary.
- Model with **TPMS**.
- Press the **SET** button when the menu is closed.
- Press the **UP** or **DOWN** button until the **Trips/Data** menu is marked on the display. Press the **SET** button to open the menu.
- Press the **UP** or **DOWN** button until the **Settings** menu is marked on the display. Press the **SET** button to open the menu.
- Press the **UP** or **DOWN** button until **Units** is marked on the display. Pressing the **SET** button again opens the menu.
- Press the **UP** or **DOWN** button until **Pressure** is marked on the display. Pressing the **SET** button again sets the unit of measure.

Select **bar** or **psi**.

7.16.10 Consumption

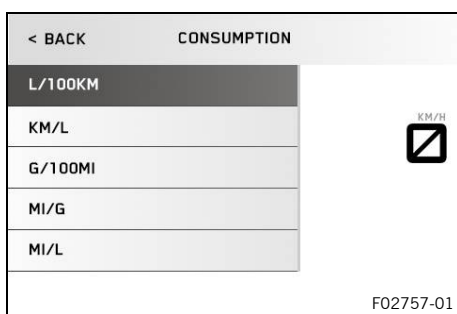

Condition

- The motorcycle is stationary.
- Press the **SET** button when the menu is closed.
- Press the **UP** or **DOWN** button until the **Trips/Data** menu is marked on the display. Press the **SET** button to open the menu.
- Press the **UP** or **DOWN** button until the **Settings** menu is marked on the display. Press the **SET** button to open the menu.
- Press the **UP** or **DOWN** button until **Units** is marked on the display. Pressing the **SET** button again opens the menu.
- Press the **UP** or **DOWN** button until **Consumption** is marked on the display. Pressing the **SET** button again sets the unit of measure.

Select one of the available consumption displays.

7.16.11 Language

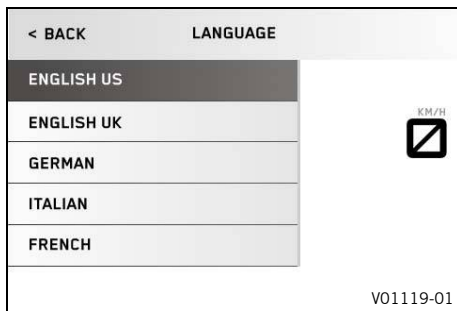

Condition

- The motorcycle is stationary.
- Press the **SET** button when the menu is closed.
- Press the **UP** or **DOWN** button until the **Trips/Data** menu is marked on the display. Press the **SET** button to open the menu.
- Press the **UP** or **DOWN** button until the **Settings** menu is marked on the display. Press the **SET** button to open the menu.
- Press the **UP** or **DOWN** button until **Language** is marked on the display. Press the **SET** button again to select the language.

The menu languages are US English, UK English, German, Italian, French, and Spanish.

7.16.12 Clock/Date

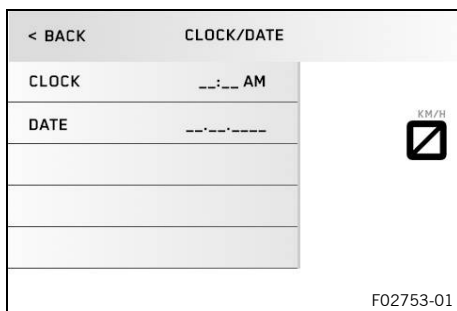

Condition

- The motorcycle is stationary.
- Press the **SET** button when the menu is closed.
- Press the **UP** or **DOWN** button until the **Trips/Data** menu is marked on the display. Press the **SET** button to open the menu.
- Press the **UP** or **DOWN** button until the **Settings** menu is marked on the display. Press the **SET** button to open the menu.
- Press the **UP** or **DOWN** button until **Clock/Date** is marked on the display. Pressing the **SET** button again opens the menu.
- Press the **UP** or **DOWN** button to set the clock and confirm with the **SET** button.
- Press the **UP** or **DOWN** button to set the date and confirm with the **SET** button.

If the 12-V battery has been disconnected, the time and date must be set.



Info

If the 12-V battery has been disconnected, the software version is also displayed.

7.16.13 DRL

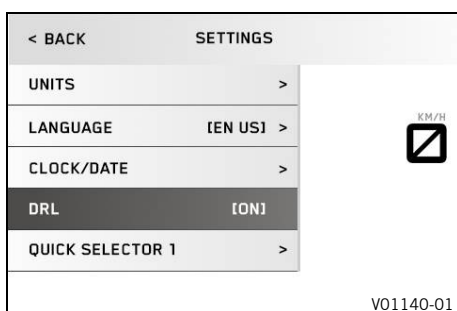

Condition

- The motorcycle is stationary.
- Press the **SET** button when the menu is closed.
- Press the **UP** or **DOWN** button until the **Trips/Data** menu is marked on the display. Press the **SET** button to open the menu.
- Press the **UP** or **DOWN** button until the **Settings** menu is marked on the display. Press the **SET** button to open the menu.



Warning

Danger of accidents When visibility is poor, the daytime running light is not a substitute for the low beam.

Automatic switching between the daytime running light and low beam may only be partially available when visibility is significantly impaired due to fog, snow or rain.

- Ensure that the appropriate type of lighting is always selected.
- If necessary switch off the daytime running lights using the menu before going on a ride or when stopped so that the low beam is switched on permanently.
- Make sure that the daytime running light is deactivated with the diagnostics tool when the menu item is not available, but the low beam is required. (Your authorized KTM workshop will be glad to help.)
- Note the legal regulations regarding the daytime running light.

- Press the **UP** or **DOWN** button until **DRL** is marked on the display. Press the **SET** button to switch the daytime running light on or off.

7.16.14 TPMS warning

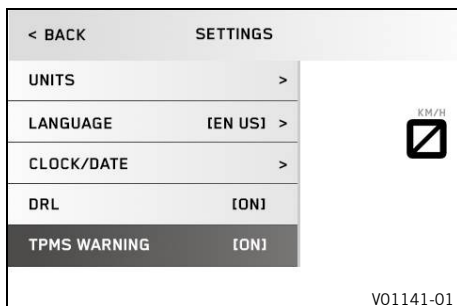

Condition

- The motorcycle is stationary.
- Model with **TPMS**.
- Press the **SET** button when the menu is closed.
- Press the **UP** or **DOWN** button until the **Trips/Data** menu is marked on the display. Press the **SET** button to open the menu.
- Press the **UP** or **DOWN** button until the **Settings** menu is marked on the display. Press the **SET** button to open the menu.
- Press the **UP** or **DOWN** button until **TPMS warning** is marked on the display. Press the **SET** button to switch indications of tire pressure being too high, or too low, on or off.

Guideline

Tire pressure when solo	
front	2.3 bar (33 psi)
rear	2.5 bar (36 psi)
Tire pressure with passenger / full payload	
front	2.3 bar (33 psi)
rear	2.6 bar (38 psi)

7.16.15 Quick Selector 1

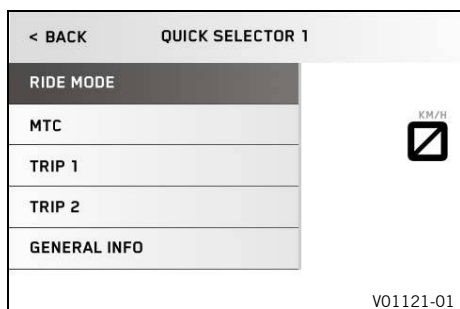
**Condition**

- The motorcycle is stationary.
- Press the **SET** button when the menu is closed.
- Press the **UP** or **DOWN** button until the **Trips/Data** menu is marked on the display. Press the **SET** button to open the menu.
- Press the **UP** or **DOWN** button until the **Settings** menu is marked on the display. Press the **SET** button to open the menu.
- Press the **UP** or **DOWN** button until the **Quick Selector 1** menu is marked on the display. Press **SET** button to open the menu.
- Press the **UP** or **DOWN** button until the desired menu is marked.
- Press **SET** button to confirm the selection.

A menu can be defined for direct selection in the **Quick Selector 1** menu.

When the menu is closed, the menu defined in **Quick Selector 1** is opened by pressing the **UP** button.

**Info**

In drive mode **TRACK** (optional), the **UP** button can be used to set the slip adjustment.

7.16.16 Quick Selector 2

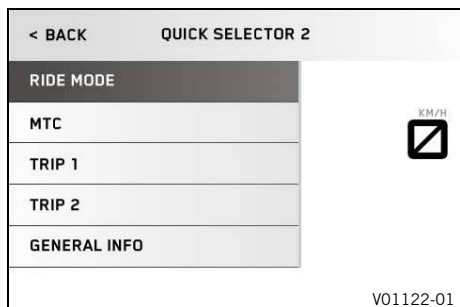
**Condition**

- The motorcycle is stationary.
- Press the **SET** button when the menu is closed.
- Press the **UP** or **DOWN** button until the **Trips/Data** menu is marked on the display. Press the **SET** button to open the menu.
- Press the **UP** or **DOWN** button until the **Settings** menu is marked on the display. Press the **SET** button to open the menu.
- Press the **UP** or **DOWN** button until the **Quick Selector 2** menu is marked on the display. Press **SET** button to open the menu.
- Press the **UP** or **DOWN** button until the desired menu is marked.
- Press **SET** button to confirm the selection.

A menu can be defined for direct selection in the **Quick Selector 2** menu.

When the menu is closed, the menu defined in **Quick Selector 2** is opened by pressing the **DOWN** button.

**Info**

In drive mode **TRACK** (optional), the **DOWN** button can be used to set the slip adjustment.

7.16.17 Set Favorites

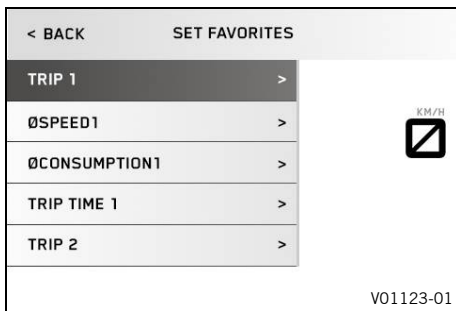

Condition

- The motorcycle is stationary.
- Press the **SET** button when the menu is closed.
- Press the **UP** or **DOWN** button until the **Trips/Data** menu is marked on the display. Press the **SET** button to open the menu.
- Press the **UP** or **DOWN** button until the **Settings** menu is marked on the display. Press the **SET** button to open the menu.
- Press the **UP** or **DOWN** button until the **Set Favorites** menu is marked on the display. Press the **SET** button to open the menu.
- Press the **UP** or **DOWN** button to select the menu. Press the **SET** button to set the menu for quick selection.

The **Favorites** menu is configured in the **Set Favorites** menu.

7.16.18 Heated Grips (optional)

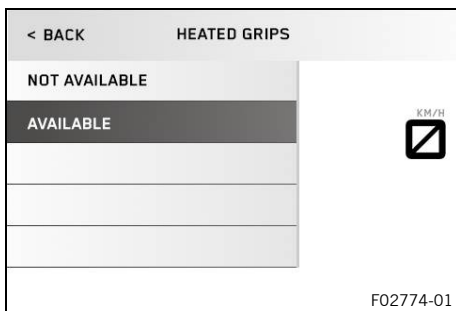

Condition

- The motorcycle is stationary.
- Press the **SET** button when the menu is closed.
- Press the **UP** or **DOWN** button until the **Trips/Data** menu is marked on the display. Press the **SET** button to open the menu.
- Press the **UP** or **DOWN** button until the **Settings** menu is marked on the display. Press the **SET** button to open the menu.
- Press the **UP** or **DOWN** button until the **Heated Grips** menu is marked on the display. Press the **SET** button to open the menu.
- Press the **UP** or **DOWN** button until **NOT AVAILABLE** or **AVAILABLE** is marked. Press **SET** button to confirm the selection.

The heated grip is activated or deactivated in the **Settings** menu. The heated grip is controlled in the **Motorcycle** menu, in submenu **Heated Grips**.

7.16.19 Service

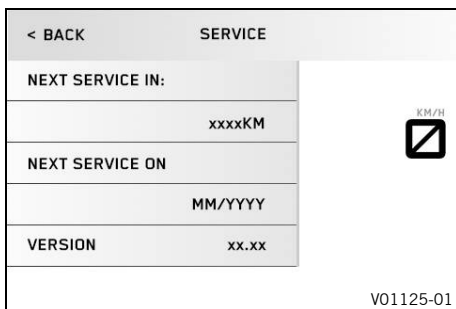

Condition

- The motorcycle is stationary.
- Press the **SET** button when the menu is closed.
- Press the **UP** or **DOWN** button until the **Trips/Data** menu is marked on the display. Press the **SET** button to open the menu.
- Press the **UP** or **DOWN** button until the **Service** menu is marked on the display. Press the **SET** button to open the menu.

The **Service** menu displays when the next service is due and the software version.

7.16.20 Extra functions

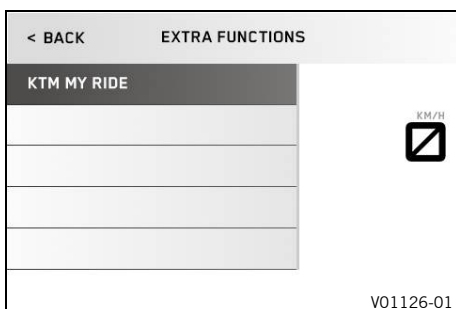

Condition

- The motorcycle is stationary.
- Motorcycle with optional supplementary function.
- Press the **SET** button when the menu is closed.
- Press the **UP** or **DOWN** button until **Trips/Data** is marked on the display. Press the **SET** button to open the menu.
- Press the **UP** or **DOWN** button until **Extra functions** is marked on the display. Press the **SET** button to open the menu.

- Use the **UP** or **DOWN** button to navigate through the extra functions.



Info

The optional extra functions are listed in **Extra functions**. The current **KTM PowerParts** and the available software for your vehicle can be found on the KTM website.

7.16.21 Warnings

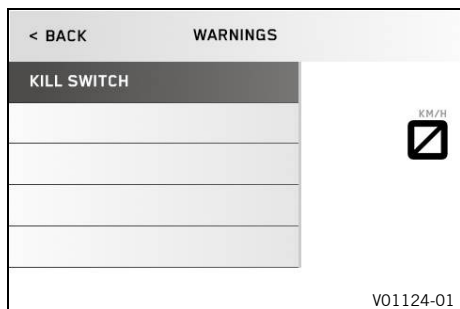

Condition

- At least one warning present.
- Press the **SET** button when the menu is closed.
- Press the **UP** or **DOWN** button until the **Trips/Data** menu is marked on the display. Press the **SET** button to open the menu.
- Press the **UP** or **DOWN** button until the **Warnings** menu is marked on the display. Press the **SET** button to open the menu.
- Use the **UP** or **DOWN** button to navigate through the warnings.

In the **Warnings** menu, warnings that occurred are displayed and stored until they are no longer enabled.

7.16.22 Ride Mode

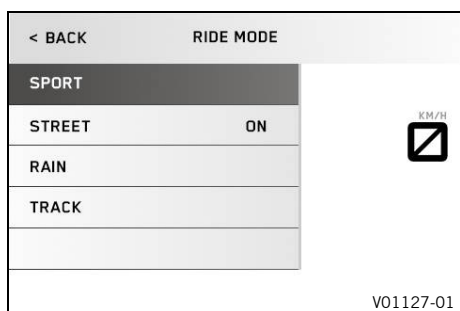

- Press the **SET** button when the menu is closed.
- Press the **UP** or **DOWN** button until the **Ride Mode** menu is marked on the display. Press **SET** button to open the menu.
- Use the **UP** or **DOWN** button to navigate through the menu. The **SET** button can be used to select engine and motorcycle traction control settings that are coordinated with each other.
 - ✓ **SPORT** – homologated performance with very direct response; the motorcycle traction control allows greater slip on the rear wheel.
 - ✓ **STREET** – homologated performance with balanced response; the motorcycle traction control allows normal slip on the rear wheel.
 - ✓ **RAIN** – reduced homologated performance for better rideability; the motorcycle traction control allows normal slip on the rear wheel.
 - ✓ **TRACK (optional)** – setting with homologated performance and extremely direct response. The motorcycle traction control and the characteristic map of the throttle response can be individually set.



Info

Do not open the throttle during the selection.

7.16.23 Track (optional)

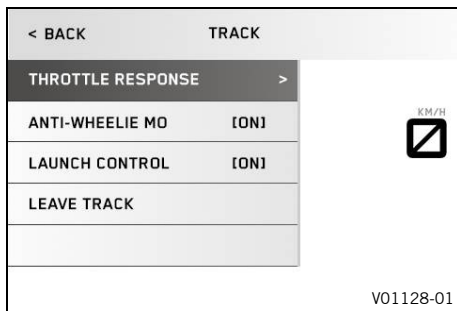

Condition

- The drive mode **TRACK** (optional) is activated.
 - Press the **SET** button when the menu is closed.
 - Press the **UP** or **DOWN** button until the **Ride Mode** menu is marked on the display. Press the **SET** button to open the menu.
 - Use the **UP** or **DOWN** button to navigate through the menu. Use the **SET** button to adjust the individual settings of the **TRACK PACK**.



Info

Do not open the throttle when setting it. The drive mode **TRACK** is ended via **Leave Track** and automatically switches to the drive mode **STREET**. Do not open the throttle when doing so.

7.16.24 Anti-wheelie mode (optional)

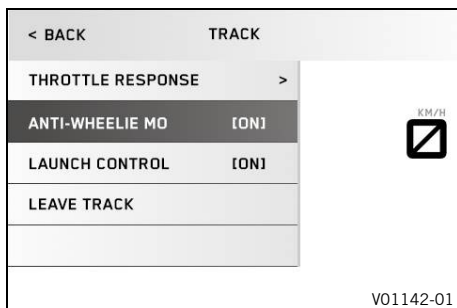

Condition

- The drive mode **TRACK** (optional) is activated.
 - Press the **SET** button when the menu is closed.
 - Press the **UP** or **DOWN** button until the menu item **Anti-wheelie mo** is marked on the display.



Warning

Danger of accidents When Anti Wheelie Mode is disabled, the motorcycle traction control no longer counteracts the raising of the front wheel.

- Only switch off the Anti Wheelie Mode if you have the appropriate experience.

- Switch the Anti Wheelie Mode on and off using the **SET** button.

7.16.25 Launch control (optional)

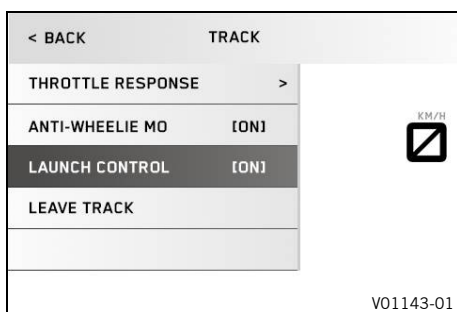

Condition

- The drive mode **TRACK** (optional) is activated.
 - Press the **SET** button when the menu is closed.
 - Press the **UP** or **DOWN** button until the menu item **Launch control** is marked on the display.
 - Switch the launch control (📖 p. 52) on and off using the **SET** button.

7.16.26 Heated Grips (optional)

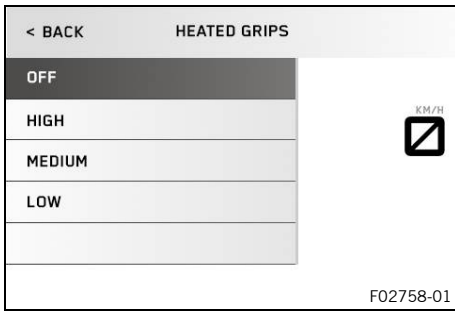

Condition

- The **Heated Grips** menu activated.
- Press the **SET** button when the menu is closed.
- Press the **UP** or **DOWN** button until the **Motorcycle** menu is marked on the display. Press the **SET** button to open the menu.
- Press the **UP** or **DOWN** button until **Heated Grips** is marked. Press the **SET** button to open the menu.
- Press the **UP** or **DOWN** button to select the heating level or **OFF**. Press the **SET** button to confirm the selection.

7.16.27 MTC

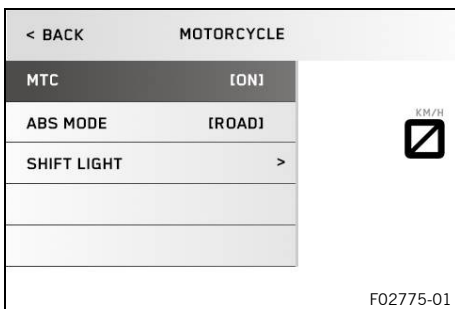

- Press the **SET** button when the menu is closed.
- Press the **UP** or **DOWN** button until the **Motorcycle** menu is marked on the display. Press the **SET** button to open the menu.
- Press the **UP** or **DOWN** button until **MTC** is marked on the display.
- Keep the **SET** button pressed for 3-5 seconds to switch **MTC** on or off.



Info

Do not open the throttle when switching on or off. After the ignition is switched on, motorcycle traction control is enabled again.

7.16.28 MTC + MSR (optional)

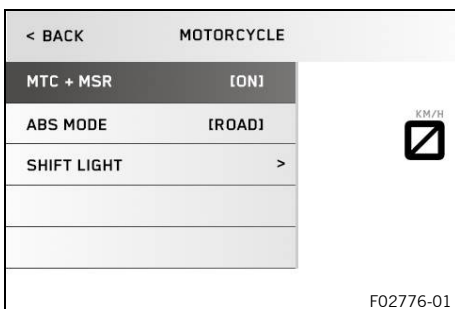

Condition

- **ABS Mode Supermoto** is not activated.
- Press the **SET** button when the menu is closed.
- Press the **UP** or **DOWN** button until the **Motorcycle** menu is marked on the display. Press the **SET** button to open the menu.
- Press the **UP** or **DOWN** button until **MTC + MSR** is marked on the display.
- Keep the **SET** button pressed for 3-5 seconds to switch **MTC + MSR** on or off.



Info

Do not open the throttle when switching on or off. After the ignition is switched on, the motorcycle traction control and engine traction torque control are enabled again.

7.16.29 ABS Mode

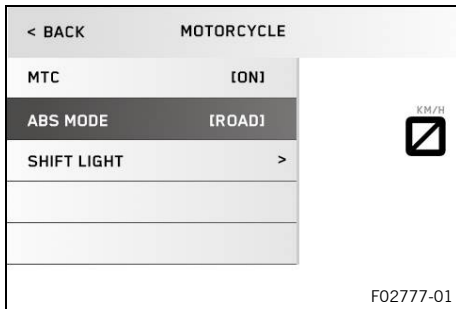

Condition

- The motorcycle is stationary.
- **ABS** is switched on.
- Press the **SET** button when the menu is closed.
- Press the **UP** or **DOWN** button until the **Motorcycle** menu is marked on the display. Press the **SET** button to open the menu.
- Press the **UP** or **DOWN** button until **ABS Mode** is marked on the display.
- Keep the **SET** button pressed for 3-5 seconds to change the ABS mode.

Info

Do not open the throttle during the selection.

If the ABS mode **Road** is enabled, ABS controls both wheels.

If the ABS mode **Supermoto** is enabled, ABS only controls the front wheel. The rear wheel is not controlled by ABS and may lock during braking maneuvers. **MSR** (optional) has been deactivated.

7.16.30 Quickshifter + (optional)

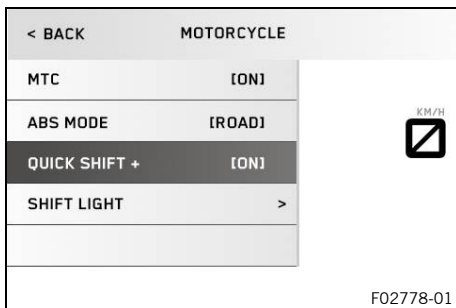

Condition

- The motorcycle is stationary.
- Press the **SET** button when the menu is closed.
- Press the **UP** or **DOWN** button until the **Motorcycle** menu is marked on the display. Press the **SET** button to open the menu.
- Press the **UP** or **DOWN** button until **Quick Shift +** is marked on the display.
- Switch quickshifter + (🔊 p. 53) on and off using the **SET** button.

7.16.31 Shift Light

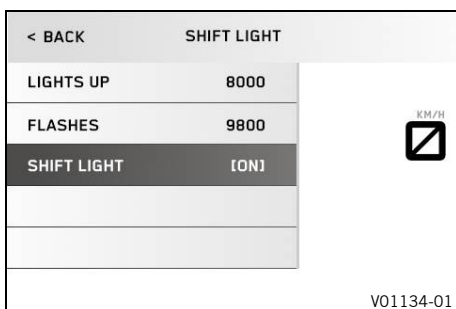

Condition

- The motorcycle is stationary.
- **ODO** > 1,000 km (600 mi).
- Press the **SET** button when the menu is closed.
- Press the **UP** or **DOWN** button until the **Motorcycle** menu is marked on the display. Press the **SET** button to open the menu.
- Press the **UP** or **DOWN** button until the **Shift Light** menu is marked on the display. Press the **SET** button to open the menu.
- Press the **UP** or **DOWN** button to select the function. Use the **SET** button to set the engine speed for the gear shift recommendation.

Once the engine speed reaches the engine speed specified at **Lights up**, the speed display lights up orange.

Once the engine speed reaches the engine speed specified at **Flashes**, the speed display flashes orange.

The gear shift recommendation can be switched on or off with the function **Shift Light**.

7.16.32 KTM MY RIDE (optional)

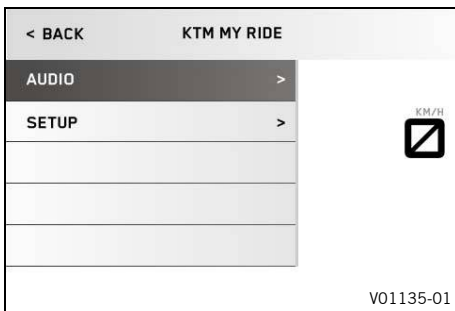
**Condition**

- Function **KTM MY RIDE** (optional) activated.
- Function **Bluetooth®** (optional) activated.
- Press the **SET** button when the menu is closed.
- Press the **UP** or **DOWN** button until the **KTM MY RIDE** menu is marked on the display. Press the **SET** button to open the menu.

In **KTM MY RIDE**, an appropriate cellphone or headset can be paired via **Bluetooth®** with the **KTM MY RIDE** control unit.

**Info**

Not every cellphone and headset is suitable for pairing with the **KTM MY RIDE** control unit. The standard **Bluetooth®** 2.1 must be supported.

7.16.33 Pairing (optional)

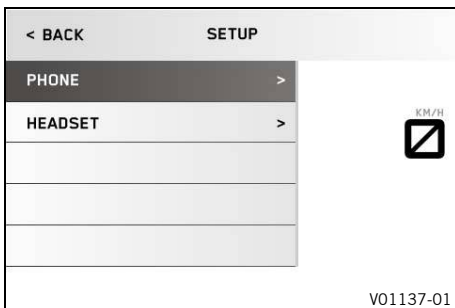
**Condition**

- The motorcycle is stationary.
- Function **KTM MY RIDE** (optional) activated.
- **Bluetooth®** (optional) is switched on.
- The **Bluetooth®** should also be switched on in the device to be paired.
- The **Bluetooth®** visibility must be activated on the device that is to be paired.
- Press the **SET** button when the menu is closed.
- Press the **UP** or **DOWN** button until the **KTM MY RIDE** menu is marked on the display. Press the **SET** button to open the menu.
- Press the **UP** or **DOWN** button until **Setup** is marked on the display. Press the **SET** button to open the menu.
- Press the **UP** or the **DOWN** button until the menu item **Phone** or **Headset** is marked.

**Info**

Two cellphones or headsets can never be paired simultaneously with the **KTM MY RIDE** control unit. Only one cellphone and one headset can be paired with the **KTM MY RIDE** control unit at the same time.

- In the submenu **Phone**, a suitable cellphone can be paired with the **KTM MY RIDE** control unit.
- In the submenu **Headset**, a suitable headset can be paired with the **KTM MY RIDE** control unit.
- Press the **SET** button to open the menu.
- When pairing the device for the first time, press the **UP** or **DOWN** button until **Pairing** is marked. Press the **SET** button to open the menu.
- Navigate to the device required using the **UP** or **DOWN** button. Confirm the selection using the **SET** button.

**Info**

The headset pairing is now finished.

- Confirmation of the **Passkey** successfully completes the cell-phone pairing.



Info

When a suitable device has been successfully paired, the name of the paired cellphone or headset appears in each case in the **Phone** or **Headset** menu.

Press the **UP** or **DOWN** button until the paired device is marked. The paired device can be deleted by pressing the **SET** button.

The device most recently linked is automatically paired with the **KTM MY RIDE** control unit when **Bluetooth®** is switched on and as soon as this device is in range and has not been previously deleted.

Not every cellphone or headset is suitable for pairing with the **KTM MY RIDE** control unit.

Make sure that the end device is in the correct pairing mode for call administration. If the end device is only paired for media playback, the call function may not work.

7.16.34 Audio player (optional)



Condition

- Function **KTM MY RIDE** (optional) activated.
- **Bluetooth®** (optional) is switched on.
- Similarly, the **Bluetooth®** is also switched on when devices are paired.
- Headset connected to a suitable audio device.
- Press the **SET** button when the menu is closed.
- Press the **UP** or **DOWN** button until the **KTM MY RIDE** menu is marked on the display. Press the **SET** button to open the menu.



Warning

Danger of accidents Headphone volume which is too high distracts attention from traffic activity.

- Always select headphone volume which is low enough for you to still clearly hear acoustic signals.

- Press the **UP** or **DOWN** button until **Audio player** is marked on the display. Press the **SET** button to open the menu.
- Press and hold the **UP** button to increase the audio volume.
- Press and hold **DOWN** button to reduce the audio volume.
- Press the **UP** button briefly to change to the next audio track.
- Press the **DOWN** button briefly to play the audio track from the beginning.
- Press the **DOWN** button twice to change to the previous audio track.
- Press the **SET** button to play or pause the audio track.



Tip

With some cellphones, the cellphone audio player needs to be started before a playback is possible. The audio function can be added to **Quick Selector 1** or **Quick Selector 2** for easier operation.

7.16.35 Telephony (optional)

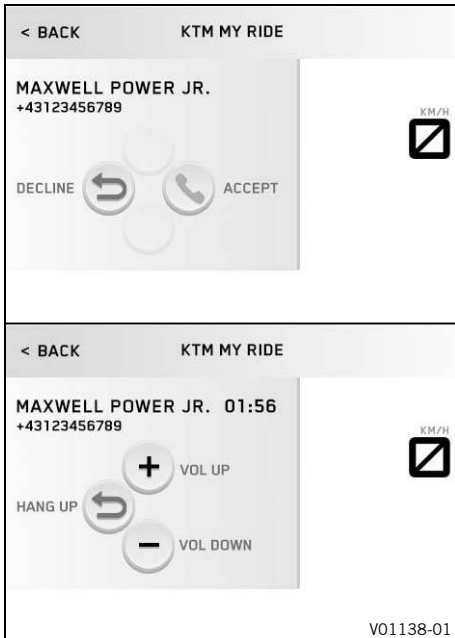

Condition

- Function **KTM MY RIDE** (optional) activated.
- **Bluetooth**® (optional) switched on.
- Similarly, the **Bluetooth**® function is also switched on when devices are paired.
- Headset linked with appropriate cellphone.



Warning

Danger of accidents Headphone volume which is too high distracts attention from traffic activity.

- Always select headphone volume which is low enough for you to still clearly hear acoustic signals.

- Press the **SET** button to accept an incoming call.
- Press the **BACK** button to reject an incoming call.
- Press and hold the **UP** button to increase the audio volume.
- Press and hold the **DOWN** button to reduce the audio volume.



Info

The call duration and contact are displayed. Depending on the cellphone settings, the contact is shown by name.

8.1 Handlebar position

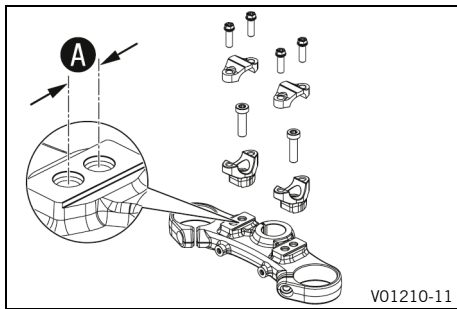

On the upper triple clamp there are two holes at a distance of **A** apart.

Hole distance A	15 mm (0.59 in)
------------------------	-----------------

The handlebar can be mounted in two different positions. This allows the handlebar to be mounted in the most comfortable position for the rider.

i Info

KTM recommends the front handlebar position when using the vehicle on a race track.

8.2 Adjusting the handlebar position ↻



Warning

Danger of accidents A repaired handlebar poses a safety risk.

If the handlebar is bent or straightened, the material becomes fatigued. The handlebar may break as a result.

- Change the handlebar if the handlebar is damaged or bent.

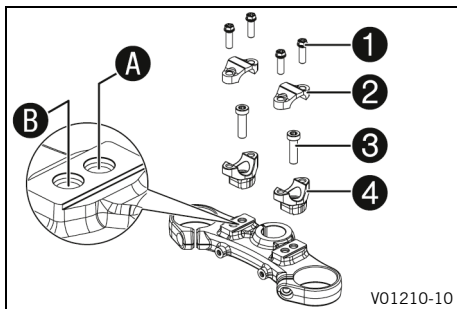

- Remove screws **1**. Take off the handlebar clamps **2**. Position the handlebar so that screws **3** are accessible.

i Info

Cover the components to protect them against damage. Do not kink the cables and lines.

- Remove screws **3**. Take off handlebar supports **4**.
- Move the handlebar supports into the desired position **A** or **B**. Mount and tighten screws **3**.

Guideline

Mount the left and right handlebar supports in the same position.		
---	--	--

Screw, handlebar support	M10	45 Nm (33.2 lbf ft) Loctite®243™
--------------------------	-----	--

- Position the handlebar.

i Info

Make sure the cables and wiring are positioned correctly.

- Position the handlebar clamp. Mount screws **1** and tighten evenly.

Guideline

Screw, handlebar clamp	M8	20 Nm (14.8 lbf ft)
------------------------	----	---------------------

8.3 Adjusting the basic position of the clutch lever

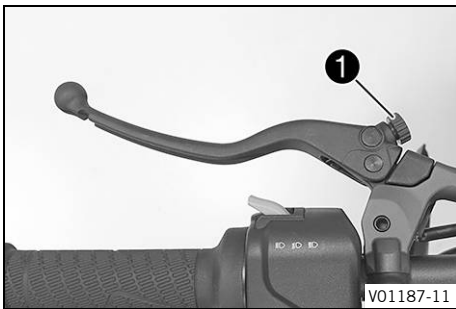

- Push the clutch lever forward.
- Adjust the basic position of the clutch lever to your hand size by turning adjusting screw ①.

i Info
 Turn the adjusting screw clockwise to increase the distance between the clutch lever and the handlebar. Turn the adjusting screw counterclockwise to decrease the distance between the clutch lever and the handlebar.
 The range of adjustment is limited.
 Only turn the adjusting screw by hand, and do not use force.
 Do not make any adjustments while riding.



8.4 Adjusting the basic position of the hand brake lever



- Push the hand brake lever forward.
- Adjust the basic position of the hand brake lever to your hand size by turning adjusting screw ①.

i Info
 Turn the adjusting screw clockwise to increase the distance between the hand brake lever and the handlebar. Turn the adjusting screw counterclockwise to decrease the distance between the hand brake lever and the handlebar.
 The range of adjustment is limited.
 Only turn the adjusting screw by hand, and do not use force.
 Do not make any adjustments while riding.



8.5 Adjusting the response of the hand brake lever



- Adjust the response of the hand brake lever with adjusting screw ①.
- ✓ 19 - Setting with large hand brake lever transmission ratio (soft response, more lever travel, less lever force).
- ✓ 20 - Setting with balanced hand brake lever response.
- ✓ 21 - Setting with small hand brake lever transmission ratio (hard response, less lever travel, more lever force).

i Info
 The transmission ratio and, therefore, the response of the hand brake lever can be changed.
 Only turn the adjusting screw by hand, and do not use force.
 Do not make any adjustments while riding.



8.6 Adjusting the basic position of the foot brake lever ↩



Warning

Danger of accidents The brake system fails in the event of overheating.

If there is no free travel on the foot brake lever, pressure builds up in the brake system on the rear brake.

- Set the free travel on the foot brake lever in accordance with the specification.

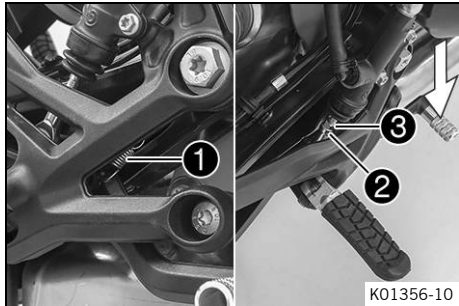

- Detach spring ①.
- Loosen nut ②.



Tip

Press the foot brake lever downwards to make this easier.

- Turn the push rod ③ to set the basic position of the foot brake lever.



Info

The range of adjustment is limited.

The screw must be screwed in by at least five full turns.

Screwing the push rod into the ball joint adjusts the foot brake lever downwards.

Screwing the push rod out of the ball joint adjusts the brake lever upwards.

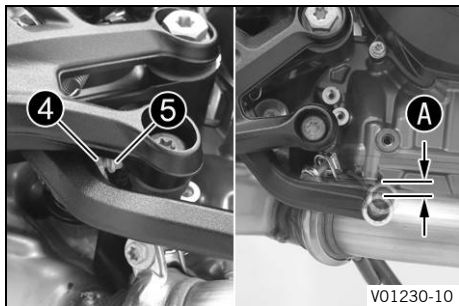

- Loosen nut ④ and turn screw ⑤ correspondingly until the free travel A is present. If necessary, adjust the basic position of the foot brake lever.

Guideline

Free travel at foot brake lever	3 ... 5 mm (0.12 ... 0.2 in)
---------------------------------	------------------------------

- Hold screw ⑤ and tighten nut ④.

Guideline

Remaining nuts, chassis	M6	10 Nm (7.4 lbf ft)
-------------------------	----	--------------------

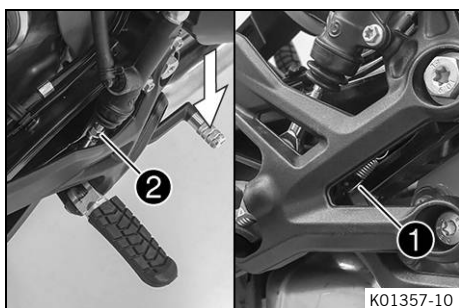

- Tighten nut ②.

Guideline

Nut, push rod, foot brake lever	M6	6 Nm (4.4 lbf ft)
---------------------------------	----	-------------------



Tip

Press the foot brake lever downwards to make this easier.

- Attach spring ①.

8.7 Checking the basic position of the shift lever

i Info
 When driving, the shift lever must not touch the rider's boot when in the basic position.
 If the shift lever is permanently touching the boot, the transmission will be subject to excessive load; this can cause a malfunction of the quickshifter + (optional).

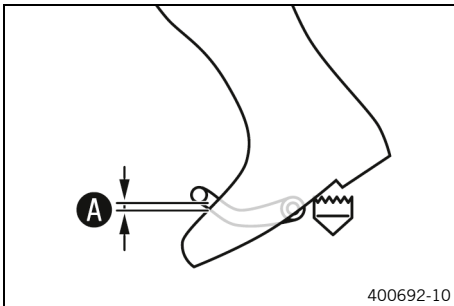

- Sit on the vehicle in the riding position and determine distance **A** between the upper edge of your boot and the shift lever.

Distance between shift lever and upper edge of boot	10 ... 20 mm (0.39 ... 0.79 in)
---	---------------------------------

- » If the distance does not meet specifications:
 - Set the basic position of the shift lever. 🛠️ (p. 47)

8.8 Adjusting the basic position of the shift lever 🛠️

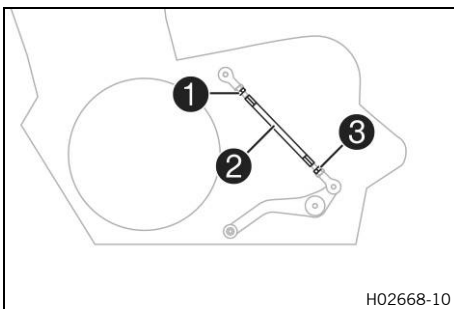

- Loosen nut **1**, holding threaded rod **2**.
- Loosen nut **3**, holding threaded rod **2**.

i Info
 Nut **3** has a left-handed thread.

- Turn threaded rod **2** to adjust the shift lever.

i Info
 The range of adjustment is limited.
 The shift lever must not come into contact with any other vehicle components during the shift procedure.

- Tighten nut **3** while holding threaded rod **2**.

Guideline

Nut, shift rod	M6LH	6 Nm (4.4 lbf ft)
----------------	------	-------------------

- Tighten nut **1** while holding threaded rod **2**.

Guideline

Nut, shift rod	M6	6 Nm (4.4 lbf ft)
----------------	----	-------------------

9.1 Advice on preparing for first use



Danger

Danger of accidents A rider who is not fit to ride poses a danger to him or herself and others.

- Do not operate the vehicle if you are not fit to ride due to alcohol, drugs or medication.
- Do not operate the vehicle if you are physically or mentally impaired.



Warning

Risk of injury Missing or poor protective clothing presents an increased safety risk.

- Wear appropriate protective clothing such as helmet, boots, gloves as well as trousers and a jacket with protectors on all rides.
- Always wear protective clothing that is in good condition and meets the legal regulations.



Warning

Danger of crashing Different tire tread patterns on the front and rear wheel impair the handling characteristic.

Different tire tread patterns can make the vehicle significantly more difficult to control.

- Make sure that only tires with a similar tire tread pattern are fitted to the front and rear wheel.



Warning

Danger of accidents Non-approved or non-recommended tires and wheels impact the handling characteristic.

- Only use tires/wheels approved by KTM with the corresponding speed index.



Warning

Danger of accidents New tires have reduced road grip.

The contact surface on new tires is not yet roughened.

- Run in new tires with moderate riding and only gradually increase the lean angle.
Run-in distance 200 km (124 mi)



Warning

Danger of accidents The brake system fails in the event of overheating.

If the foot brake lever is not released, the brake linings drag continuously.

- Take your foot off the foot brake lever if you do not want to brake.



Info

When using your vehicle, remember that others may feel disturbed by excessive noise.

- Make sure that the pre-sales inspection work has been carried out by an authorized KTM workshop.
 - ✓ You will receive a delivery certificate when the vehicle is handed over.
- Before riding for the first time, read the entire Owner's Manual carefully.
- Get to know the controls.
- Adjust the basic position of the clutch lever. (📖 p. 45)
- Adjust the basic position of the hand brake lever. (📖 p. 45)
- Adjust the basic position of the foot brake lever. (📖 p. 46)
- Get used to the handling characteristic of the motorcycle in a suitable area before making a longer trip. Try also to ride as slowly as possible to get a better feel for the motorcycle.
- Hold the handlebar firmly with both hands and keep your feet on the footrests when riding.



Warning

Fire hazard The hot exhaust system may burn luggage.

- Fasten your luggage in such a way that it cannot be burned or singed by the hot exhaust system.

- If luggage is carried, ensure it is fixed firmly as close as possible to the center of the vehicle and ensure even weight distribution between the front and rear wheels.
- Do not exceed the maximum permissible weight and maximum permissible axle loads.

Guideline

Maximum permissible overall weight	430 kg (948 lb.)
Maximum permissible front axle load	160 kg (353 lb.)
Maximum permissible rear axle load	270 kg (595 lb.)

10.1 Checks and maintenance measures when preparing for use

i Info

Before every trip, check the condition of the vehicle and ensure that it is roadworthy. The vehicle must be in perfect technical condition when it is being operated.

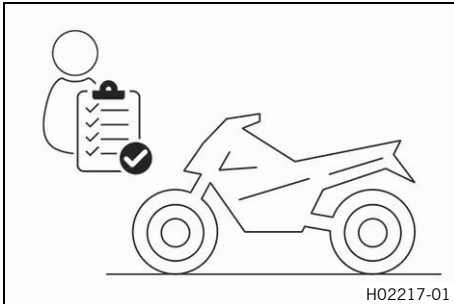

- Check the engine oil level. (📖 p. 114)
- Check the front brake fluid level. (📖 p. 79)
- Check the rear brake fluid level. (📖 p. 82)
- Check that the brake linings of the front brake are secured. (📖 p. 81)
- Check that the brake linings of the rear brake are secured. (📖 p. 84)
- Check that the brake system is functioning properly.
- Check coolant level in the compensating tank. (📖 p. 107)
- Check the chain for dirt. (📖 p. 72)
- Check the chain tension. (📖 p. 73)
- Check the tire condition. (📖 p. 91)
- Check tire pressure. (📖 p. 92)
- Check the settings of all controls and ensure that they can be operated smoothly.
- Check that the electrical system is functioning properly.
- Check that luggage is properly secured.
- Sit on the motorcycle and check the rear mirror setting.
- Check the fuel level.



10.2 Starting the vehicle



Danger

Danger of poisoning Exhaust gases are toxic and inhaling them may result in unconsciousness and death.

- Always make sure there is sufficient ventilation when running the engine.
- Use effective exhaust extraction when starting or running the engine in an enclosed space.



Caution

Danger of accidents Electronic components and safety devices will be damaged if the 12-V battery is discharged or missing.

If the 12-V battery is discharged or defective, malfunctions in the vehicle electronics can occur, especially when starting.

- Never operate the vehicle with a discharged 12-V battery or without a 12-V battery.

Note

Engine damage High revving speed with a cold engine negatively impacts the lifespan of the engine.

- Always run the engine warm at a low speed.

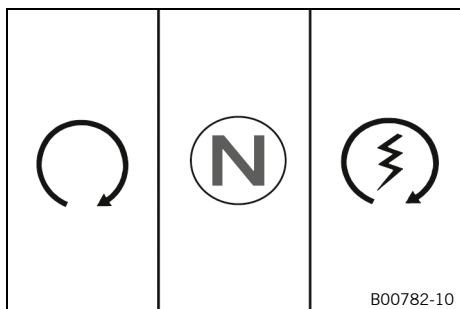

- Take the motorcycle off the side stand and sit on the motorcycle.
- Make sure that the start button/emergency OFF switch is in the middle position ○.
- Switch on the ignition by turning the ignition key to the position ○.

Guideline

To avoid malfunctions in the control unit communication, do not switch the ignition off and on in rapid succession.

- ✓ After you switch on the ignition, you can hear the fuel pump working for about two seconds. The function check of the combination instrument is run at the same time.
- ✓ The ABS warning lamp lights up and goes back out after starting off.
- Shift the transmission to neutral position.
 - ✓ The green idle indicator lamp **N** lights up.
- Press the start button/emergency OFF switch into the lower position Ⓣ.

i Info

Only press the start button/emergency OFF switch into the lower position Ⓣ when the combination instrument function check has been completed.

Do not open the throttle to start.

If the starting attempt is unsuccessful, wait for 15 seconds before making another attempt at starting.

After 6 unsuccessful starting attempts, do not try again, and check the vehicle for other malfunctions instead.

This motorcycle is equipped with a safety starting system. You can only start the engine if the transmission is in neutral or if the clutch lever is pulled when a gear is engaged. If the side stand is folded out and you shift into gear and release the clutch lever, the engine stops.

10.3 Starting off

- Pull the clutch lever, engage 1st gear, release the clutch lever slowly and simultaneously open the throttle carefully.

10.4 Launch-Control (optional)

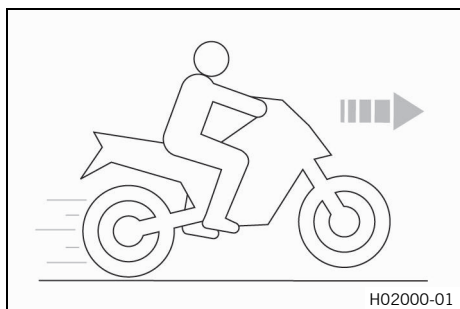

Launch Control is a vehicle electronics function.

Launch control adjusts the engine speed in order to achieve the best possible acceleration.

Launch control can be used for starting off for a maximum of three times in succession. Launch control is temporarily deactivated after the third starting off in order to protect the engine, transmission and cooling system from overloading.

Launch control is also deactivated if all conditions for activation are no longer met.

Launch control is enabled again in the following cases: the engine runs for at least three minutes, the engine is switched off for 20 minutes or a distance of 1.5 km (0.93 mi) has been covered.

10.5 Starting off with launch control (optional)



Warning

Danger of accidents Launch control enables very powerful acceleration which may ask too much of a novice rider.

- Only use the launch control if you have the appropriate experience.
- Do not use launch control on public roads.

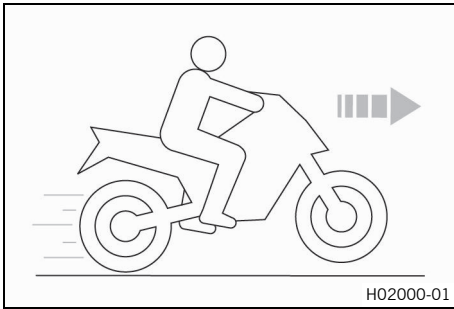

Condition

The drive mode **TRACK** (optional) is activated.

First gear is engaged.

The TC indicator lamp does not light up.

Coolant temperature: > 60 °C (> 140 °F)

Total riding distance covered: > 1,000 km (> 620 mi)

- Activate launch control in the combination instrument.
 - ✓ The number of available starts is indicated on the start screen.
 - Apply full throttle with the clutch lever pulled.
 - ✓ The engine speed is adjusted.
- 9,000 rpm
- ✓ The TC indicator lamp flashes quickly.
 - Release clutch lever quickly but in a controlled manner.

10.6 Quickshifter + (optional)

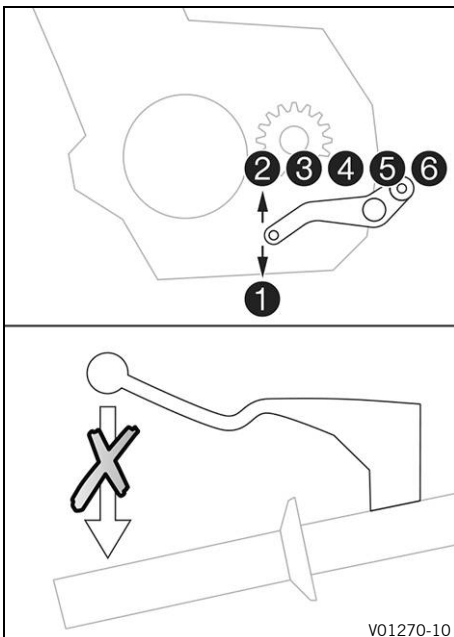

If the quickshifter + is activated, you can shift up and down without actuating the clutch.

Because there is no need to close the throttle grip, uninterrupted gear shifts are possible.

The quickshifter + uses the shifter shaft position to check whether or not a shift should be initiated, and sends a corresponding signal to the engine control.

If the quickshifter + is disabled in the combination instrument, the clutch needs to be actuated in the normal way for each shift.

10.7 Shifting, riding



Warning

Danger of accidents Abrupt load alterations can cause the vehicle to get out of control.

- Avoid abrupt load alterations and sudden braking actions.
- Adapt your speed to the road conditions.



Warning

Danger of accidents If you change down at high engine speed, the rear wheel blocks and the engine races.

- Do not change into a low gear at high engine speed.



Warning

Danger of accidents An incorrect ignition key position causes malfunctions.

- Do not change the ignition key position while driving.



Warning

Danger of accidents Adjustments to the vehicle distract attention from traffic activity.

- Make all adjustments when the vehicle is at a standstill.



Warning

Risk of injury The passenger may fall from the motorcycle if they conduct themselves incorrectly.

- Ensure that the passenger sits correctly on the passenger seat, places his or her feet on the passenger foot pegs and holds on to the rider or the grab handles.
- Note the regulations governing the minimum age of passengers in your country.



Warning

Danger of accidents A risky riding style constitutes a major risk.

- Comply with traffic regulations and ride defensively and with foresight to detect sources of danger as early as possible.



Warning

Danger of accidents Cold tires have reduced road grip.

- Ride the first miles carefully on every journey at moderate speed until the tires reach operating temperature.



Warning

Danger of accidents New tires have reduced road grip.

The contact surface on new tires is not yet roughened.

- Run in new tires with moderate riding and only gradually increase the lean angle.
Run-in distance 200 km (124 mi)



Warning

Danger of accidents Total weight and axle loads influence the handling characteristic.

The total weight consists of: operational motorcycle with a full tank, rider and, if necessary, a passenger with protective clothing and helmet, and, if necessary, mounted luggage.

- Do not exceed the maximum permissible overall weight or the axle loads.



Warning

Danger of accidents Improper mounting of cases, tank rucksacks or other luggage impairs the handling characteristics.

Luggage mounted incorrectly can slip while the vehicle is in motion.

- Mount and secure all luggage according to the manufacturer's instructions.
- Check that your luggage is fixed properly at regular intervals.



Warning

Danger of accidents A fall can damage the vehicle more seriously than it may first appear.

- Check the vehicle after a fall as you do when preparing for use.

Note

Engine damage Unfiltered intake air has a negative effect on the service life of the engine.

Dust and dirt will enter the engine without an air filter.

- Only operate the vehicle if it is equipped with an air filter.

Note

Engine failure Overheating damages the engine.

- If the coolant temperature warning is displayed, stop immediately and take care not to endanger yourself or other traffic participants in the process.
- Allow the engine and cooling system to cool down.
- Check and, if necessary, correct the coolant level on the cooling system while it is in a cooled state.

Note

Transmission damage Incorrect use of the quickshifter + will damage the transmission.

The quickshifter + can only be used if the function is enabled in the combination instrument.

The quickshifter + is not active if you pull the clutch lever.

- Only use the quickshifter + in the permitted speed range shown.



Info

If unusual noises occur while riding, stop immediately (taking care not to endanger yourself or other road users in the process), switch off the engine and contact an authorized KTM workshop.

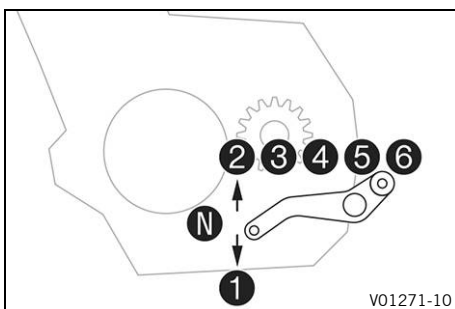

- Shift into a higher gear when conditions allow (incline, road situation, etc.).
- Release the throttle while simultaneously pulling the clutch lever, shift into the next gear, release the clutch lever, and open the throttle.





Info

You can see the positions of the 6 forward gears in the figure. The neutral or idle position is between the first and second gears. First gear is used for starting off or for steep inclines.

The operating temperature is reached when 5 bars of the temperature indicator light up.

- After reaching maximum speed by fully opening the throttle grip, turn the throttle back so it is $\frac{3}{4}$ open. This will barely reduce the speed, but fuel consumption will be considerably lower.

- Only accelerate up to a speed suitable for the road surface and weather conditions. Particularly in bends, do not shift, and accelerate very carefully.
- Brake if necessary and close the throttle at the same time in order to shift down.
- Pull clutch lever and shift into a lower gear, release the clutch lever slowly, and open the throttle or shift again.
- If the engine stalls (e.g., at a crossroads), just pull clutch lever and press the start button/emergency OFF switch into the lower position (3). The transmission must not be shifted into neutral.
- Switch off the engine if running at idle speed or stationary for a long time.
- If the oil pressure warning lamp  lights up during a trip, stop immediately and switch off the engine. Contact an authorized KTM workshop.
- If the malfunction indicator lamp  lights up during a trip, please contact an authorized KTM workshop as soon as possible.
- If the general warning lamp  lights up during a trip, the display shows a message.

i Info

Very important messages are stored in the **Warnings** menu.

- If the ice warning appears in the combination instrument, the roads may be icy. Adjust your speed to the road conditions.
- If the quickshifter + (optional) is enabled in the combination instrument, you can shift up in the speed range shown without pulling the clutch lever.

i Info

The minimum engine speed before shifting up in revolutions per minute is shown in the figure. Pull the shift lever quickly back to the stop without changing the throttle twist grip position.

- If the quickshifter + (optional) is enabled in the combination instrument, you can shift down in the speed range shown without pulling the clutch lever.

i Info

The maximum engine speed before shifting down in revolutions per minute is shown in the figure. Depress the shift lever quickly back to the stop without changing the throttle twist grip position.

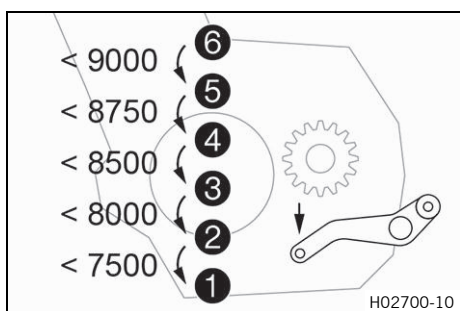
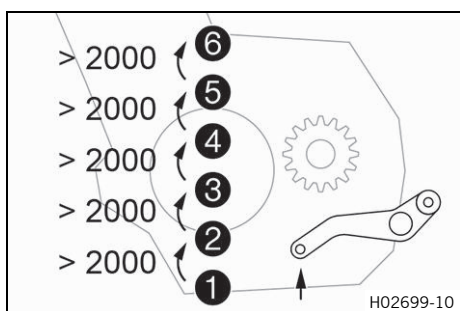

10.8 Engine traction torque control (MSR)

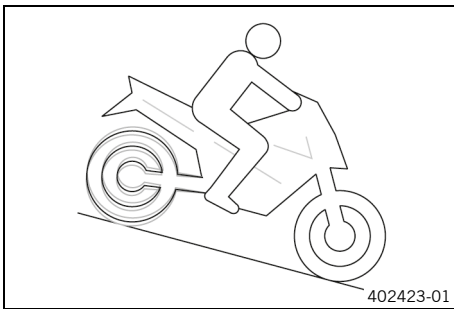

The **MSR** is a function of the engine control.

If the engine braking effect is too great, the **MSR** prevents the rear wheel from locking or sliding away on a sloping position.

To avoid slip of the rear wheel, the **MSR** only opens the throttle valve as far as absolutely necessary.

The **MSR** is applied on surfaces, where the friction coefficient is too low to open the slipper clutch.

To further increase ride safety, the **MSR** is slope dependent.

i Info

When the **ABS** or active **ABS** mode **Supermoto** is switched off, the **MSR** is not active.

10.9 Applying the brakes



Warning

Danger of accidents Moisture and dirt impair the brake system.

- Brake carefully several times to dry out and remove dirt from the brake linings and the brake discs.



Warning

Danger of accidents A spongy pressure point on the front or rear brake reduces braking efficiency.

- Check the brake system and do not continue riding until the problem is eliminated. (Your authorized KTM workshop will be glad to help.)



Warning

Danger of accidents The brake system fails in the event of overheating.

If the foot brake lever is not released, the brake linings drag continuously.

- Take your foot off the foot brake lever if you do not want to brake.



Warning

Danger of accidents Higher total weight increases the stopping distance.

- Take the longer stopping distance into account when carrying a passenger or luggage with you.



Warning

Danger of accidents Salt on the roads impairs the brake system.

- Brake carefully several times to remove salt from the brake linings and the brake discs.



Warning

Danger of accidents ABS may increase the stopping distance in certain situations.

- Adjust application of the brakes to the respective riding situation and riding surface conditions.



Warning

Danger of accidents Excessively forceful application of the brakes blocks the wheels.

The **ABS** effectiveness is only ensured if it is switched on.

- Leave the **ABS** switched on in order to benefit from the protective effect.



Warning

Danger of accidents The rear wheel can lock due to the engine braking effect.

- Pull in the clutch, if you perform emergency or full braking, or if you brake on a slippery ground.

- When braking, release the throttle and apply the front and rear brakes at the same time.



Info

When ABS is active, you can achieve maximum braking power even on low grip surfaces such as sandy, wet, or slippery terrain without locking of the tires.



Warning

Danger of accidents Banked or laterally sloping ground reduces the maximum possible delay.

- If possible finish braking before going into a bend.

- Braking should always be completed before you go into a bend. Change down to a lower gear appropriate to your road speed.
- On long downhill stretches, use the braking effect of the engine. Change down one or two gears, but do not over rev the engine. As a result, you will have to apply the brakes far less frequently and the brake system will not overheat.

10.10 Stopping, parking



Warning

Risk of injury People who act without authorization endanger themselves and others.

- Do not leave the vehicle unattended if the engine is running.
- Protect the vehicle against access by unauthorized persons.
- Lock the steering and remove the ignition key if you leave the vehicle unattended.



Warning

Danger of burns Some vehicle components become very hot when the vehicle is operated.

- Do not touch any parts such as the exhaust system, radiator, engine, shock absorber, or brake system before the vehicle parts have cooled down.
- Let the vehicle parts cool down before you perform any work on the vehicle.

Note

Material damage The vehicle may be damaged by incorrect procedure when parking.

Significant damage may be caused if the vehicle rolls away or falls over.

The components for parking the vehicle are designed only for the weight of the vehicle.

- Park the vehicle on a firm and level surface.
- Ensure that nobody sits on the vehicle when the vehicle is parked on a stand.

Note

Fire hazard Hot vehicle components pose a fire hazard and explosion risk.

- Do not park the vehicle near to materials which are highly flammable or explosive.
- Allow the vehicle to cool down before covering it.

- Apply the brakes on the motorcycle.
- Shift the transmission to neutral position.
- Switch off the ignition by turning the ignition key to the position ☒.



Info

If the engine is switched off with the emergency OFF switch and the ignition remains switched on at the ignition lock, power continues to flow to most power consumers. This discharges the 12-V battery. You should therefore always switch off the engine with the ignition lock – the emergency OFF switch is intended for emergencies only.

- Park the motorcycle on a firm surface.
- Swing side stand forward with your foot as far as it will go and lean the vehicle on it.
- Lock the steering by turning the handlebar fully to the left, pressing down the ignition key to the position ☒ and turning it to the position ☑. To make the steering lock engage more easily, move the handlebar a little to the left and right. Remove the ignition key.



10.11 Transporting

Note

Danger of damage The parked vehicle can roll away or fall over.

- Park the vehicle on a firm and level surface.

Note

Fire hazard Hot vehicle components pose a fire hazard and explosion risk.

- Do not park the vehicle near to materials which are highly flammable or explosive.
- Allow the vehicle to cool down before covering it.

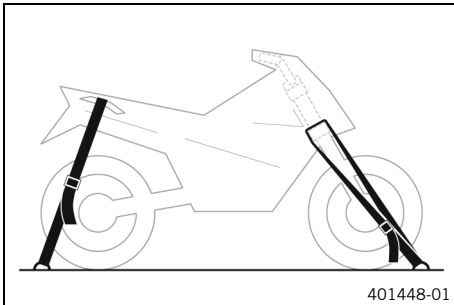

- Switch off the engine.
- Use tension belts or other suitable devices to secure the motorcycle against falling over or rolling away.

10.12 Towing in the event of a breakdown

Note

Danger of damage Towing away using a towing vehicle is not an appropriate vehicle recovery method.

Damage to the drive train or transmission may occur during towing.

- Do not use towing equipment where the wheels of the broken down vehicle remain on the road and rotate as it is towed.
- Always transport a broken down vehicle on a trailer or on the loading area of a transport vehicle.

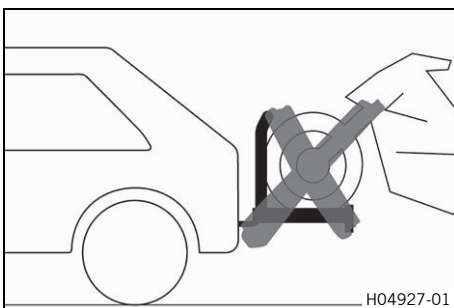

- Ensure that the broken down vehicle is properly secured on the trailer or transport vehicle.
- Observe local regulations for the recovery of broken down vehicles.

10.13 Refueling



Danger

Fire hazard Fuel is highly flammable.

The fuel in the fuel tank expands when warm and can escape if overfilled.

- Do not fuel the vehicle in the vicinity of open flames or lit cigarettes.
- Switch off the engine for refueling.
- Make sure that no fuel is spilled; particularly not on hot parts of the vehicle.
- If any fuel is spilled, wipe it off immediately.
- Observe the specifications for refueling.



Warning

Danger of poisoning Fuel is harmful to health.

- Avoid skin, eye and clothing contact with fuel.
- Immediately consult a doctor if you swallow fuel.
- Do not inhale fuel vapors.
- Rinse the affected area immediately with plenty of water in the event of contact with the skin.
- Rinse the eyes thoroughly with water, and consult a doctor in case of fuel contact with the eyes.
- Change your clothing if fuel spills on them.

Note

Material damage Inadequate fuel quality causes the fuel filter to quickly become clogged.

In some countries and regions, the available fuel quality and cleanliness may not be sufficient. This will result in problems with the fuel system.

- Refuel only with clean fuel that meets the specified standards. (Your authorized KTM workshop will be glad to help.)



Note

Environmental hazard Improper handling of fuel is a danger to the environment.

- Do not allow fuel to enter the groundwater, the soil, or the sewage system.

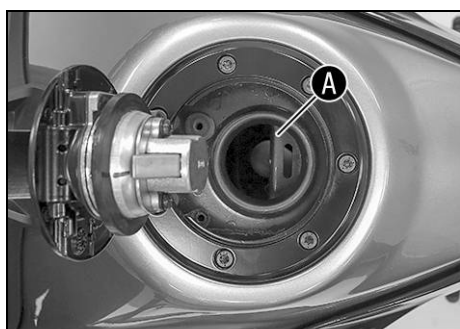

- Switch off the engine.
- Open fuel tank filler cap. (📖 p. 18)
- Fill the fuel tank with fuel up to the lower edge **A** of the filler neck.

Fuel tank capacity, approx.	14 l (3.7 US gal)	Super unleaded (ROZ 95) (📖 p. 137)
-----------------------------	----------------------	--

- Close the fuel tank filler cap. (📖 p. 19)



V01463-10

11.1 Additional information

Any further work that results from the service work must be ordered separately and invoiced separately. Different service intervals may apply in your country, depending on the local operating conditions. Individual service intervals and scopes may change in the course of technical developments. The most up-to-date service schedule can always be found on KTM Dealer.net. Your authorized KTM dealer will be happy to advise you.

11.2 Service schedule

	every 48 months	every 24 months	every 12 months	every 30,000 km (18,600 mi)	every 15,000 km (9,300 mi)	after 1,000 km (620 mi)
Read out the fault memory using the KTM diagnostics tool. 🛠️	○	●	●	●	●	●
Program the shift shaft sensor. 🛠️	○	●	●	●	●	●
Check that the electrical system is functioning properly. 🛠️	○	●	●	●	●	●
Check that the brake linings of the front brake are secured. (📖 p. 81)	○	●	●	●	●	●
Check that the brake linings of the rear brake are secured. (📖 p. 84)	○	●	●	●	●	●
Check the brake discs. (📖 p. 79)	○	●	●	●	●	●
Check the brake lines for damage and leakage. 🛠️	○	●	●	●	●	●
Check the front brake fluid level. (📖 p. 79)	○	●	●	●	●	●
Change the front brake fluid. 🛠️					●	●
Check the rear brake fluid level. (📖 p. 82)	○	●	●	●	●	●
Change the rear brake fluid. 🛠️					●	●
Check the free travel of the clutch lever. (📖 p. 117)	○	●	●	●	●	●
Check the free travel of the foot brake lever. (📖 p. 82)	○	●	●	●	●	●
Change the engine oil and the oil filter, clean the oil screens. 🛠️ (📖 p. 114)	○	●	●	●	●	●
Check all hoses (e.g. fuel, cooling, bleeder, drainage hoses, etc.) and sleeves for cracking, tightness, and correct routing. 🛠️		●	●	●	●	●
Empty the drainage hoses. 🛠️	○	●	●	●	●	●
Check the cables for damage and for routing without kinks. 🛠️		●	●	●	●	●
Check the frame. 🛠️			●			
Check the link fork. 🛠️			●			
Check the fork bearing for play. 🛠️		●	●			
Check the steering head bearing for play. 🛠️	○	●	●	●	●	●
Check the wheel bearing for play. 🛠️		●	●			
Check the shock absorber and fork for leaks. Perform a fork service and shock absorber service as needed, when possible and depending on how the vehicle is used. 🛠️	○	●	●	●	●	●
Check the tire condition. (📖 p. 91)	○	●	●	●	●	●
Check tire pressure. (📖 p. 92)	○	●	●	●	●	●
Check the chain, rear sprocket, engine sprocket, and chain guide. (📖 p. 75)		●	●	●	●	●
Check the chain tension. (📖 p. 73)	○	●	●	●	●	●
Grease all moving parts (e.g. side stand, hand lever, chain, etc.) and check for smooth operation. 🛠️	○	●	●	●	●	●
Change the spark plugs. 🛠️			●			

11 SERVICE SCHEDULE

		every 48 months		every 24 months		every 12 months	
		every 30,000 km (18,600 mi)		every 15,000 km (9,300 mi)		after 1,000 km (620 mi)	
Check the valve clearance. 🛠️			•				
Change the air filter, clean the air filter box. 🛠️		•	•				
Check the fuel pressure and the absorbing elements of the fuel tank bracket. 🛠️		•	•	•	•	•	•
Check the headlight setting. (📖 p. 103)	○	•	•				
Check the tightness of the safety-relevant screws and nuts which are easily accessible. 🛠️	○	•	•	•	•	•	•
Clean the dust boots of the fork legs. 🛠️ (📖 p. 69)		•	•				
Check the antifreeze and coolant level. (📖 p. 106)	○	•	•	•	•		
Change the coolant. 🛠️							•
Check that the radiator fan is functioning properly. 🛠️	○	•	•	•	•	•	•
Final check: Check the vehicle is roadworthy and take a test ride. 🛠️	○	•	•	•	•	•	•
Read out the fault memory using the KTM diagnostics tool after a test ride. 🛠️	○	•	•	•	•	•	•
Set the service interval display. 🛠️	○	•	•	•	•	•	•
Make a service entry in KTM Dealer.net . 🛠️	○	•	•	•	•	•	•

- One-time interval
- Periodic interval

12.1 Fork/shock absorber

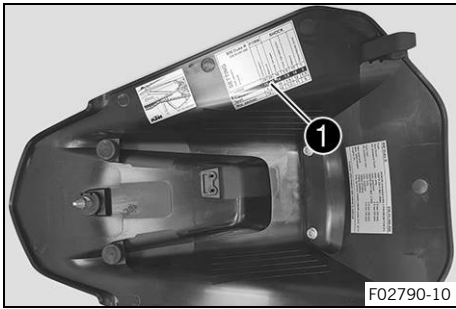

The fork and the shock absorber offer many options of adapting the chassis to your riding style and the payload.

i Info
To help you adapt the vehicle, we have summarized our findings in Table 1. You can find the table under the passenger seat cover.

These adjustments should be understood as a guideline and should always be the basis for one's personal suspension setting. Do not change the adjustments at random, as otherwise the riding characteristics could deteriorate, particularly at high speeds.

12.2 Adjusting the compression damping of the fork

i Info
The hydraulic compression damping determines the fork suspension behavior.



- Turn white adjuster 1 clockwise as far as it will go.

i Info
Adjuster 1 is located at the upper end of the left fork leg. The compression damping is located in left fork leg **COMP** (white adjuster). The rebound damping is located in right fork leg **REB** (red adjuster).

- Turn counterclockwise by the number of clicks corresponding to the fork type.

Guideline

Compression damping	
Comfort	20 clicks
Standard	15 clicks
Sport	4 clicks
Full payload	15 clicks

i Info
Turn clockwise to increase damping; turn counterclockwise to reduce damping during compression.

12.3 Adjusting the rebound damping of the fork

i Info
The hydraulic rebound damping determines the fork suspension behavior.



- Turn red adjuster **1** clockwise as far as it will go.

i Info

Adjuster **1** is located at the upper end of the right fork leg.

The rebound damping is located in right fork leg **REB** (red adjuster). The compression damping is located in left fork leg **COMP** (white adjuster).

- Turn counterclockwise by the number of clicks corresponding to the fork type.

Guideline

Rebound damping	
Comfort	20 clicks
Standard	15 clicks
Sport	10 clicks
Full payload	15 clicks

i Info

Turn clockwise to increase the damping; turn counterclockwise to reduce damping when the shock absorber rebounds.

12.4 Compression damping of the shock absorber

The compression damping of the shock absorber is divided into two ranges: high-speed and low-speed. High-speed and low-speed refer to the compression speed of the rear wheel suspension and not to the vehicle speed.

The high-speed compression adjuster, for example, has an effect when riding over an asphalt edge: the rear wheel suspension compresses quickly.

The low-speed compression adjuster has an effect, for example, when riding over long ground swells: the rear wheel suspension compresses slowly.

These two ranges can be adjusted separately, although the transition between high-speed and low-speed is gradual. Thus, modifications in the high-speed range affect the compression damping in the low-speed range and vice versa.

12.5 Adjusting the low-speed compression damping of the shock absorber



Caution

Risk of injury Parts of the shock absorber will move around if the shock absorber is detached incorrectly.

The shock absorber is filled with highly compressed nitrogen.

- Please follow the description provided. (Your authorized KTM workshop will be glad to help.)



Info

The effect of the low-speed compression adjuster can be seen in slow to normal compression of the shock absorber.

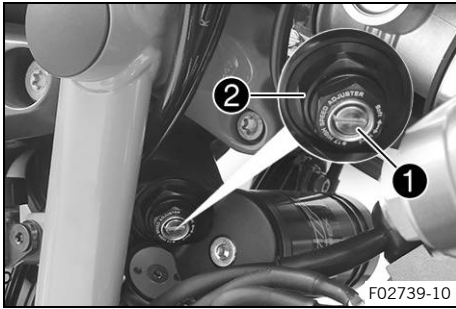

- Turn adjusting screw **1** clockwise with a screwdriver as far as the last perceptible click.

i Info
Do not loosen fitting **2**!

- Turn counterclockwise by the number of clicks corresponding to the shock absorber type.

Guideline

Low-speed compression damping	
Comfort	16 clicks
Standard	14 clicks
Sport	10 clicks
Full payload	14 clicks

i Info
Turn clockwise to increase damping; turn counterclockwise to reduce damping during slow to normal compression.



12.6 Adjusting the high-speed compression damping of the shock absorber

! Caution
Risk of injury Parts of the shock absorber will move around if the shock absorber is detached incorrectly. The shock absorber is filled with highly compressed nitrogen.
- Please follow the description provided. (Your authorized KTM workshop will be glad to help.)

i Info
The effect of the high-speed compression adjuster can be seen in fast compression of the shock absorber.

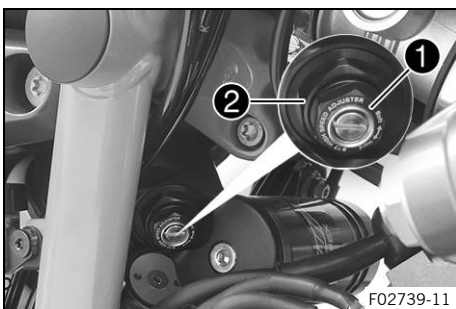

- Using an open end wrench, turn adjusting screw **1** clockwise all the way.

i Info
Do not loosen fitting **2**!

- Turn counterclockwise by the number of turns corresponding to the shock absorber type.

Guideline

High-speed compression damping	
Comfort	1.5 turns
Standard	1.5 turns
Sport	1.5 turns
Full payload	1.5 turns

i Info
Turn clockwise to increase damping; turn counterclockwise to reduce damping during fast compression.



12.7 Adjusting the rebound damping of the shock absorber



Caution

Risk of injury Parts of the shock absorber will move around if the shock absorber is detached incorrectly.

The shock absorber is filled with highly compressed nitrogen.

- Please follow the description provided. (Your authorized KTM workshop will be glad to help.)

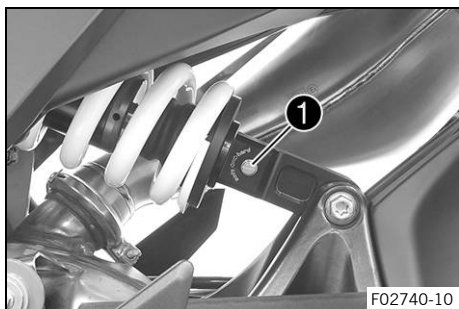

- Turn adjusting screw ① clockwise up to the last perceptible click.
- Turn counterclockwise by the number of clicks corresponding to the shock absorber type.

Guideline

Rebound damping	
Comfort	17 clicks
Standard	14 clicks
Sport	12 clicks
Full payload	11 clicks



Info

Turn clockwise to increase damping; turn counterclockwise to reduce damping.

12.8 Adjusting the spring preload of the shock absorber ↴



Warning

Danger of accidents Modifications to the suspension setting may seriously alter the handling characteristic.

- Ride slowly to start with after making adjustments to get the feel of the new handling characteristic.



Info

The spring preload defines the initial status of the spring operation on the shock absorber. The best spring preload setting is achieved when it is set for the weight of the rider and that of any luggage and a passenger, thus ensuring an ideal compromise between handling and stability.

Preparatory work

Condition

- The link fork is relieved of weight.

Main work

- Turn adjusting screw ① counterclockwise all the way.
- Turn it clockwise by the number of turns corresponding to the shock absorber type and use.

Guideline

Spring preload - Preload Adjuster	
Comfort	1 turn
Standard	3 turns
Sport	5.5 turns
Full payload	6 turns

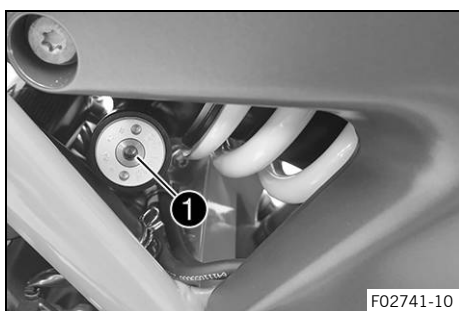

**Info**

Turn clockwise to increase the spring preload; turn counterclockwise to reduce the spring preload.



13.1 Raising the motorcycle with the rear lifting gear

Note

Danger of damage The parked vehicle can roll away or fall over.

- Park the vehicle on a firm and level surface.

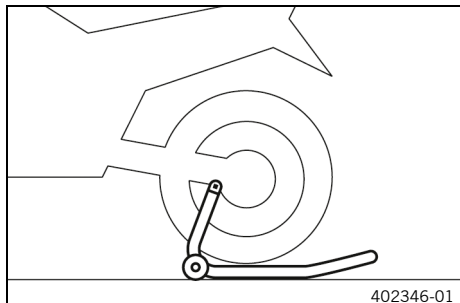

- Mount the supports of the lifting gear.
- Insert the adapter in the rear lifting gear.

Retaining adapter (63529955000)

Rear wheel work stand (69329955000)

- Stand the motorcycle upright, align the lifting gear to the swingarm and the adapters, and raise the motorcycle.

13.2 Removing the rear of the motorcycle from the lifting gear

Note

Danger of damage The parked vehicle can roll away or fall over.

- Park the vehicle on a firm and level surface.

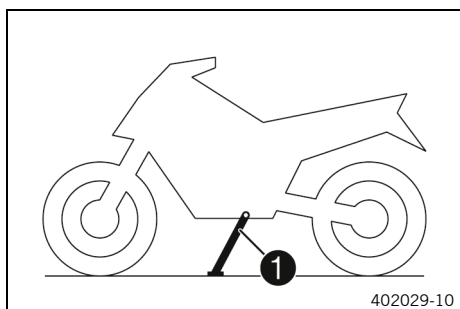

- Secure the motorcycle against falling over.
- Remove the rear lifting gear and lean the vehicle on side stand 1.
- Remove the retaining adapter from the link fork.

13.3 Lifting the motorcycle with the front lifting gear

Note

Danger of damage The parked vehicle can roll away or fall over.

- Park the vehicle on a firm and level surface.

Preparatory work

- Raise the motorcycle with the rear lifting gear. (📖 p. 68)

Main work

- Remove screw 1.

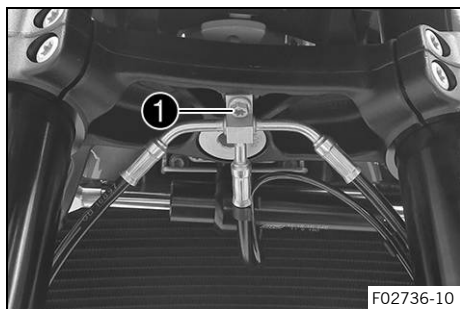

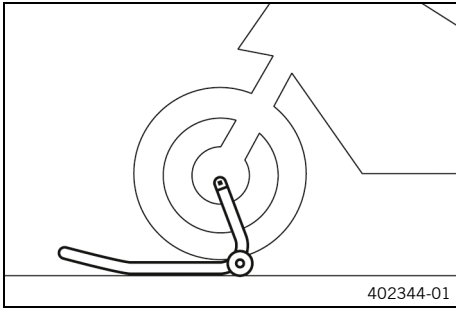

- Move the handlebar to the straight-ahead position. Align the lifting gear at the front with the adapters to the fork legs.

Front wheel work stand, small (61129965100)

i Info
Always raise the motorcycle at the rear first.
Pay attention to the brake lines.

- Lift the motorcycle at the front.

13.4 Taking the motorcycle off the front lifting gear

Note

Danger of damage The parked vehicle can roll away or fall over.

- Park the vehicle on a firm and level surface.

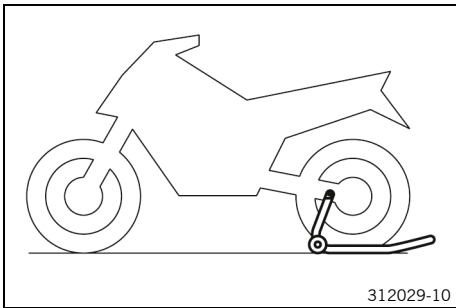

- Secure the motorcycle against falling over.
- Remove the front lifting gear.

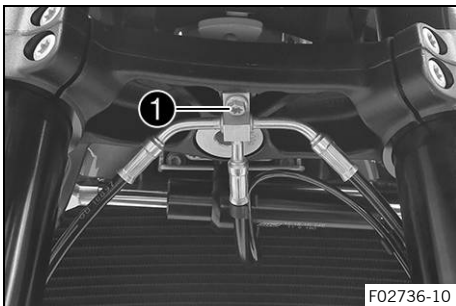

- Position the brake line.
- Mount and tighten screw ①.

Guideline

Remaining screws, chassis	M5	5 Nm (3.7 lbf ft)
---------------------------	----	-------------------

13.5 Cleaning the dust boots of the fork legs

Preparatory work

- Raise the motorcycle with the rear lifting gear. (📖 p. 68)
- Lift the motorcycle with the front lifting gear. (📖 p. 68)

Main work

- Push dust boots ① of both fork legs downward.



i Info
The dust boots remove dust and coarse dirt particles from the inside fork tubes. Over time, dirt can accumulate behind the dust boots. If this dirt is not removed, the oil seals behind can start to leak.



Warning

Danger of accidents Oil or grease on the brake discs reduces the braking effect.

- Always keep the brake discs free of oil and grease.
- Clean the brake discs with brake cleaner when necessary.

- Clean and oil the dust boots and inner fork tubes of both fork legs.

Universal oil spray (📖 p. 138)

- Press the dust boots back into their installation position.
- Remove excess oil.

Finishing work

- Take the motorcycle off the front lifting gear. (📖 p. 69)
- Remove the rear of the motorcycle from the lifting gear. (📖 p. 68)

13.6 Removing the passenger seat

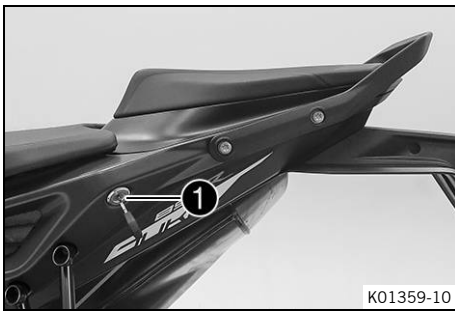

- Insert the ignition key in seat lock ❶ and turn it clockwise.
- Raise the rear of the passenger seat cover, push it toward the rear, and remove it upward.
- Remove the ignition key from the seat lock.



Info

The vehicle has been set up in the factory for one-person operation. Only an authorized KTM workshop may carry out the conversion.

The components for one-person operation and for operation with a passenger are included in the scope of supply.

Always ensure that the legal requirements are observed, e.g., entry in the vehicle documents if applicable.

13.7 Mounting the passenger seat

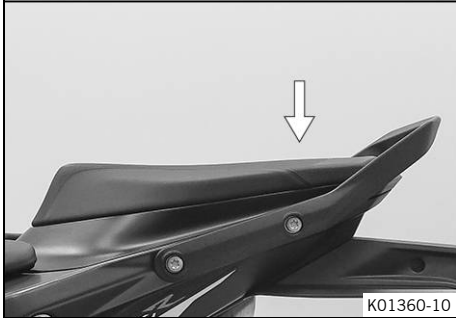
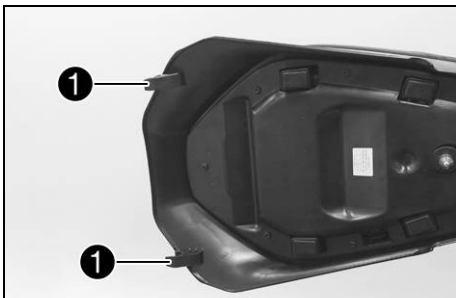

- Hook holding lugs ① of the passenger seat onto the storage compartment, lower the rear and push forward.
- Press the passenger seat downward until it clicks into place.



Warning

Danger of accidents The seat can come loose from the anchoring if it is not mounted correctly.

- After assembly, check whether the seat is correctly locked and cannot be pulled up.

- Finally, check that the passenger seat is correctly mounted.



Info

The vehicle has been set up in the factory for one-person operation. Only an authorized KTM workshop may carry out the conversion.

The components for one-person operation and for operation with a passenger are included in the scope of supply.

Always ensure that the legal requirements are observed, e.g., entry in the vehicle documents if applicable.



13.8 Removing the front rider's seat

Preparatory work

- Remove the passenger seat. (📖 p. 70)

Main work

- Remove screws ①.
- Raise the rear of the front rider's seat, pull the seat back, and lift it off.

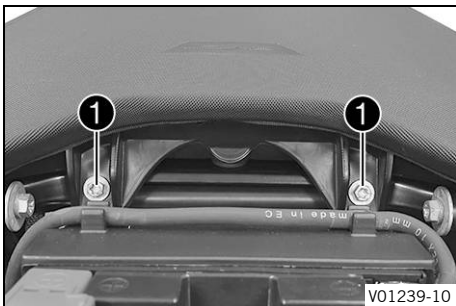

13.9 Mounting the front rider's seat

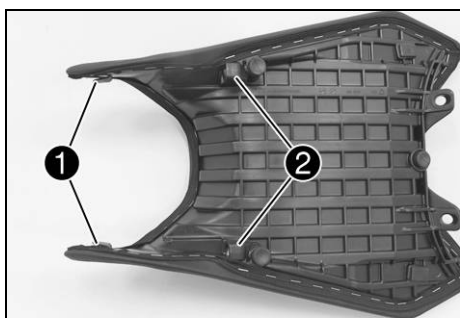

Main work

- Push the front rider's seat forward and lower at the rear.
 - ✓ The holding lugs 1 engage in the loops A on the tank.
 - ✓ The holding lugs 2 engage in the loops B on the frame.

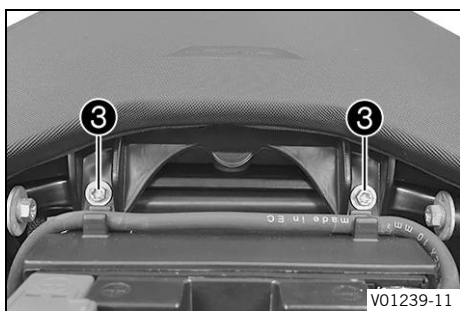
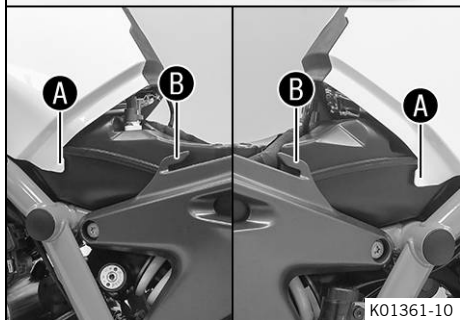

- Mount and tighten screws 3.

Guideline

Remaining screws, chassis	M6	10 Nm (7.4 lbf ft)
---------------------------	----	--------------------

- Finally, check that the front rider's seat is correctly mounted.

Finishing work

- Mount the passenger seat. (📖 p. 71)

13.10 Checking the chain for dirt

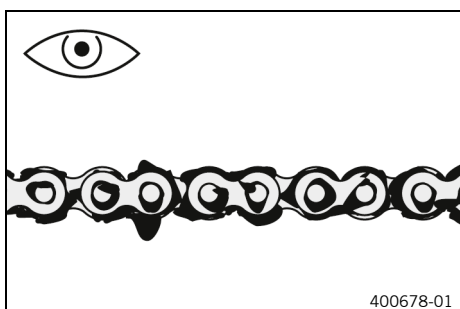

- Check the chain for heavy soiling.
 - » If the chain is very dirty:
 - Clean the chain. (📖 p. 73)

13.11 Cleaning the chain



Warning

Danger of accidents Lubricants on the tires reduces the road grip.

- Remove lubricants from the tires using a suitable cleaning agent.



Warning

Danger of accidents Oil or grease on the brake discs reduces the braking effect.

- Always keep the brake discs free of oil and grease.
- Clean the brake discs with brake cleaner when necessary.



Note

Environmental hazard Hazardous substances cause environmental damage.

- Dispose of oils, grease, filters, fuel, cleaning agents, brake fluid, etc., correctly and in compliance with the applicable regulations.



Info

The service life of the chain depends largely on its maintenance.

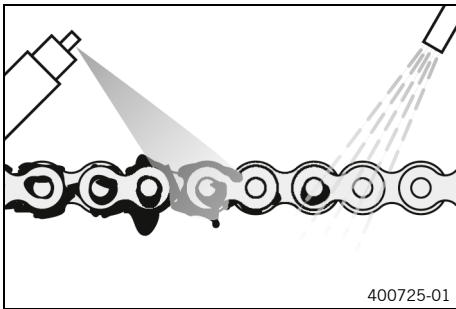

Preparatory work

- Raise the motorcycle with the rear lifting gear. (📖 p. 68)

Main work

- Rinse off loose dirt with a soft jet of water.
- Remove old grease residue with chain cleaner.

Chain cleaner (📖 p. 138)

- After drying, apply chain spray.

Street chain spray (📖 p. 138)

Finishing work

- Remove the rear of the motorcycle from the lifting gear. (📖 p. 68)



13.12 Checking the chain tension



Warning

Danger of accidents Incorrect chain tension damages components and results in accidents.

If the chain is tensioned too much, the chain, engine sprocket, rear sprocket, transmission and rear wheel bearings wear more quickly. Some components may break if overloaded.

If the chain is too loose, the chain may fall off the engine sprocket or the rear sprocket. As a result, the rear wheel locks or the engine will be damaged.

- Check the chain tension regularly.
- Set the chain tension in accordance with the specification.

Preparatory work

- Raise the motorcycle with the rear lifting gear. (📖 p. 68)

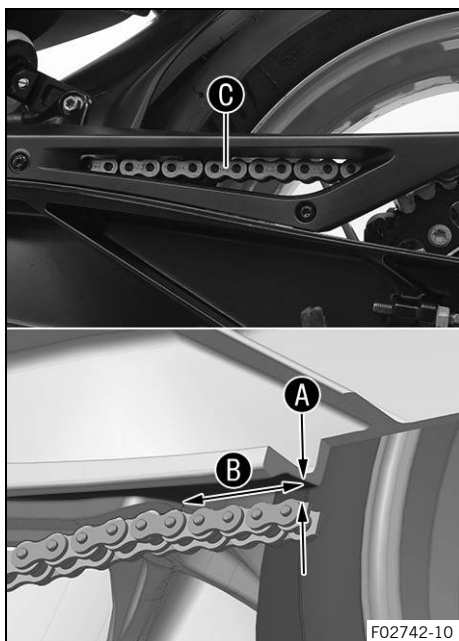

Main work

- Shift the transmission to neutral position.
- Push the chain behind the chain sliding piece up and determine the chain tension **A** between the swingarm and the upper edge of the chain.

Guideline

Distance B from the chain sliding piece	2.5 cm (0.98 in)
Measure the distance from the flat part of the swingarm directly above the chain, not from the edge of the swingarm.	

i Info

Top chain section **C** must be taut.
Chain wear is not always even. Repeat this measurement at different chain positions.

Chain tension	2 ... 5 mm (0.08 ... 0.2 in)
---------------	------------------------------

- » If the chain tension does not meet the specification:
 - Adjust the chain tension. (📖 p. 74)

Finishing work

- Remove the rear of the motorcycle from the lifting gear. (📖 p. 68)

13.13 Adjusting the chain tension



Warning

Danger of accidents Incorrect chain tension damages components and results in accidents.

If the chain is tensioned too much, the chain, engine sprocket, rear sprocket, transmission and rear wheel bearings wear more quickly. Some components may break if overloaded.

If the chain is too loose, the chain may fall off the engine sprocket or the rear sprocket. As a result, the rear wheel locks or the engine will be damaged.

- Check the chain tension regularly.
- Set the chain tension in accordance with the specification.

Preparatory work

- Raise the motorcycle with the rear lifting gear. (📖 p. 68)
- Check the chain tension. (📖 p. 73)

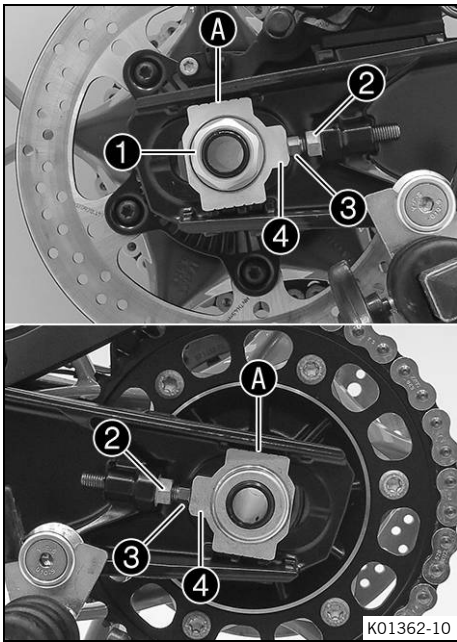

Main work

- Loosen nut ①.
- Loosen nuts ②.
- Adjust the chain tension by turning adjusting screws ③ left and right.

Guideline

Chain tension	2 ... 5 mm (0.08 ... 0.2 in)
Turn the adjusting screws ③ on the left and right so that the markings on the left and right chain adjusters ④ are in the same position relative to the reference marks A. The rear wheel is then correctly aligned.	

i Info

The top chain section must be taut. Chain wear is not always even. Repeat this measurement at different chain positions.

- Tighten nuts ②.
- Make sure that chain adjusters ④ are fitted correctly on adjusting screws ③.
- Tighten nut ①.

Guideline

Nut, rear wheel spindle	M25x1.5	90 Nm (66.4 lbf ft) Thread and contact area of wheel spindle greased
-------------------------	---------	---

Finishing work

- Check the chain tension. (📖 p. 73)
- Remove the rear of the motorcycle from the lifting gear. (📖 p. 68)



13.14 Checking the chain, rear sprocket, engine sprocket, and chain guide

Preparatory work

- Raise the motorcycle with the rear lifting gear. (📖 p. 68)

Main work

- Check the rear sprocket and engine sprocket for wear.
 - » If the rear sprocket and engine sprocket are worn:
 - Change the drivetrain kit. 🛠️

i Info

The engine sprocket, rear sprocket, and chain should always be replaced together.

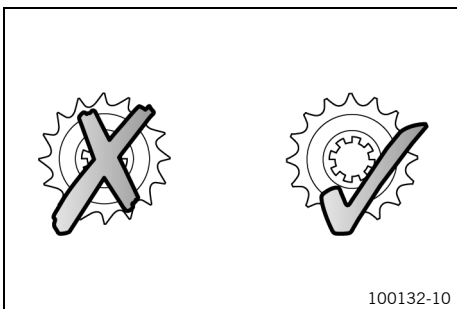

13 SERVICE WORK ON THE CHASSIS

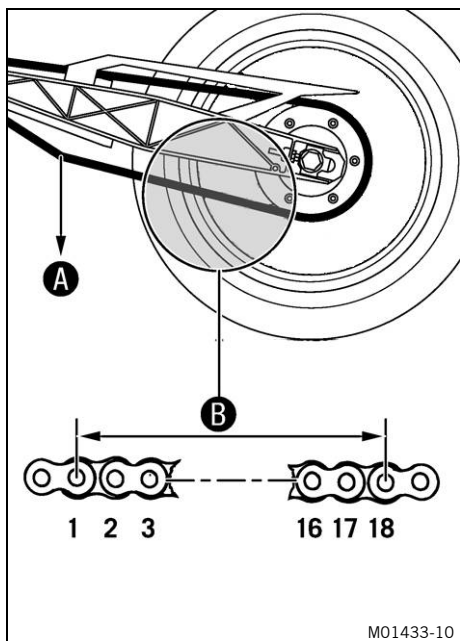

- Shift the transmission to neutral position.
- Pull on the lower chain section with the specified weight **A**.

Guideline

Weight of chain wear measurement	15 kg (33 lb.)
----------------------------------	----------------

- Measure distance **B** of 18 chain rollers in the lower chain section.

i Info
Chain wear is not always even. Repeat this measurement at different chain positions.

Maximum distance B from 18 chain rollers at the longest chain section	272 mm (10.71 in)
--	-------------------

- » If distance **B** is greater than the specified measurement:
 - Change the drivetrain kit. 🛠️

i Info
When a new chain is mounted, the rear sprocket and engine sprocket should also be changed. New chains wear out faster on old, worn sprockets. For safety reasons, the chain has no chain joint.

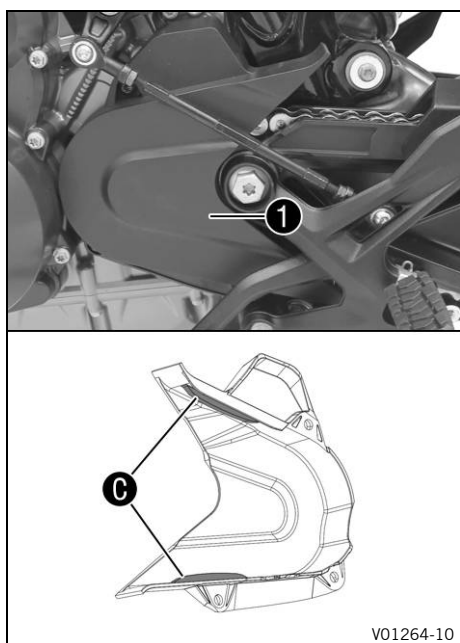

- Check the engine sprocket cover **1** for wear.
 - » If the engine sprocket cover is highly worn in the marked area **C**:
 - Change the engine sprocket cover. 🛠️
- Check the engine sprocket cover **1** for tightness.
 - » If the engine sprocket cover is loose:
 - Tighten the screws on the engine sprocket cover.

Guideline

Screw, engine sprocket cover	M5	5 Nm (3.7 lbf ft) Loctite®243™
------------------------------	----	--

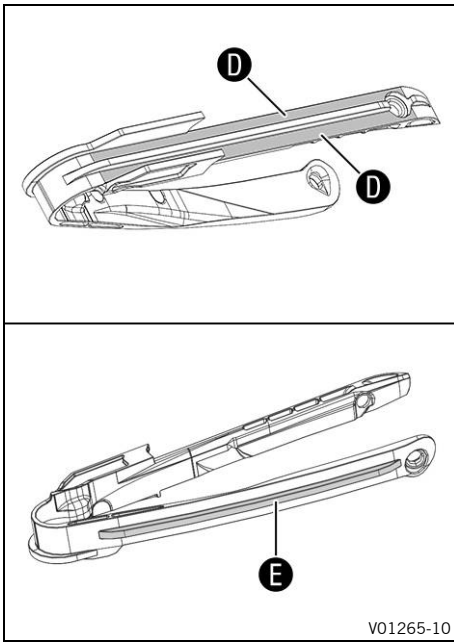

- Check the chain sliding guard for wear.
 - » If continuous signs of wear to the chain are visible on the chain sliding guard in the area **D** marked:
 - Replace the chain sliding guard. 🛠️
 - » If the chain sliding guard is highly worn on the underside in the marked area **E**:
 - Replace the chain sliding guard. 🛠️
- Check that the chain sliding guard is firmly seated.
 - » If the chain sliding guard is loose:
 - Tighten the screws on the chain sliding guard.

Guideline

Remaining screws, chassis	M5	5 Nm (3.7 lbf ft)
---------------------------	----	-------------------

Finishing work

- Remove the rear of the motorcycle from the lifting gear. (📖 p. 68)



14.1 Anti-lock braking system (ABS)

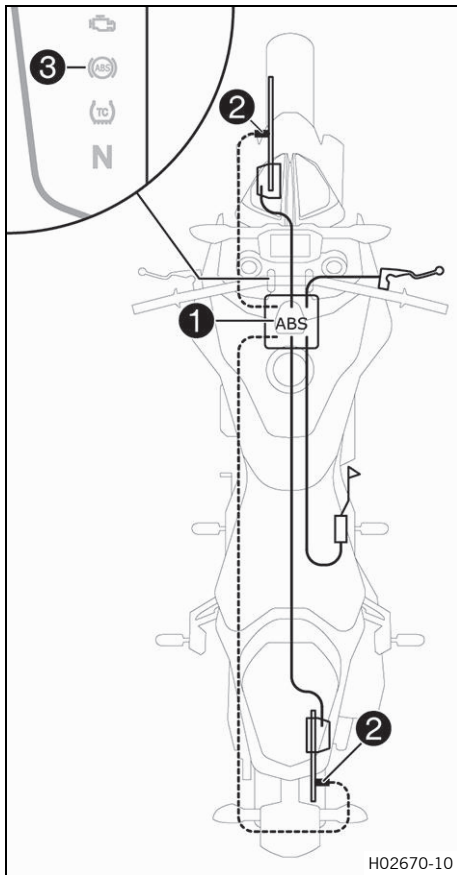

ABS module **1**, which consists of a hydraulic unit, ABS control unit, and return pump, is installed under the fuel tank. One wheel speed sensor **2** is located in each case on the front and the rear wheel.



Warning

Danger of accidents Changes to the vehicle impair the function of the ABS.

- Do not make any changes to the suspension travel.
- Only use spare parts on the brake system which have been approved and recommended by KTM.
- Only use tires/wheels approved by KTM with the corresponding speed index.
- Maintain the specified tire pressure.
- Ensure that service work and repairs are performed professionally. (Your authorized KTM workshop will be glad to help.)

The ABS is a safety system that prevents locking of the wheels when driving straight ahead without the influence of lateral forces.



Warning

Danger of accidents Driving aids can reduce the probability of a fall only within physical limits.

It is not always possible to compensate for certain riding situations, for example with luggage loaded with a high center of gravity, varying road surfaces, steep descents or full braking without disengaging the gear.

- Adapt your riding style to the road conditions and your driving ability.

The ABS operates with two independent brake circuits (front and rear brakes). During normal operation, the brake system operates like a conventional brake system without ABS. When the ABS control unit detects a locking tendency in a wheel, ABS begins regulating the brake pressure. The control function causes a slight pulsing of the hand and foot brake levers.

The ABS warning lamp **3** must light up after the ignition is switched on and go out after starting off. If it does not go out after starting off or if it lights up while riding, this indicates a fault in the ABS. In this case, the ABS is no longer enabled and the wheels may lock during braking. The brake system itself stays functional; only ABS control is not available.

The ABS warning lamp may also light up if the rotating speeds of the front and rear wheels differ greatly under extreme riding conditions, for example when making "wheelies" or if the rear wheel spins. This causes the ABS to switch off.

To reactivate the ABS, stop the vehicle and switch off the ignition. The ABS is reactivated when the vehicle is switched on again. The ABS warning lamp goes out after starting off.

14.2 Checking the brake discs



Warning

Danger of accidents Worn-out brake discs reduce the braking effect.

- Make sure that worn-out brake discs are replaced immediately. (Your authorized KTM workshop will be glad to help.)

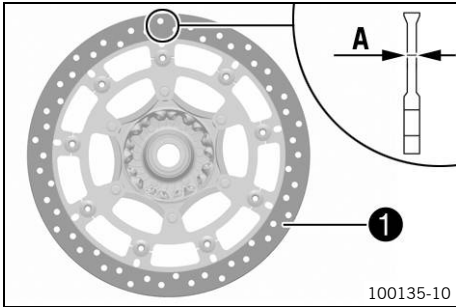

- Check the front and rear brake disc thickness at multiple points for the dimension **A**.



Info

Wear will reduce the thickness of the brake disc at contact surface **1** of the brake linings.

Brake discs - wear limit	
front	4.2 mm (0.165 in)
rear	4.5 mm (0.177 in)

- » If the brake disc thickness is less than the specified value.
 - Change the front brake discs. 🛠️
 - Change the rear brake disc. 🛠️
- Check the front and rear brake discs for damage, cracking, and deformation.
 - » If the brake disc exhibits damage, cracking, or deformation:
 - Change the front brake discs. 🛠️
 - Change the rear brake disc. 🛠️



14.3 Checking the front brake fluid level



Warning

Danger of accidents An insufficient brake fluid level will cause the brake system to fail.

If the brake fluid level drops below the specified marking or the specified value, the brake system is leaking or the brake linings are worn down.

- Check the brake system and do not continue riding until the problem is eliminated. (Your authorized KTM workshop will be glad to help.)



Warning

Danger of accidents Old brake fluid reduces the braking effect.

- Make sure that brake fluid for the front and rear brake is changed in accordance with the service schedule. (Your authorized KTM workshop will be glad to help.)

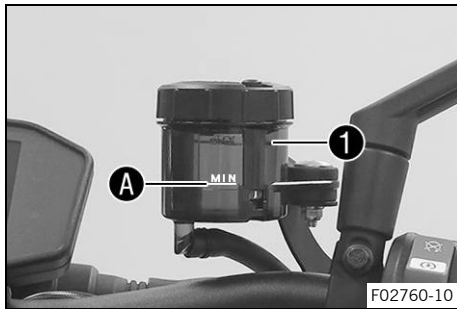

- Move the brake reservoir mounted on the handlebar to a horizontal position.
- Check the brake fluid level in brake fluid reservoir ①.
 - » If the brake fluid level has dropped below **MIN** marking A:
 - Add front brake fluid. 📖 (p. 80)

14.4 Adding front brake fluid 📖



Warning

Danger of accidents An insufficient brake fluid level will cause the brake system to fail.

If the brake fluid level drops below the specified marking or the specified value, the brake system is leaking or the brake linings are worn down.

- Check the brake system and do not continue riding until the problem is eliminated. (Your authorized KTM workshop will be glad to help.)



Warning

Skin irritation Brake fluid causes skin irritation.

- Keep brake fluid out of the reach of children.
- Wear suitable protective clothing and safety glasses.
- Do not allow brake fluid to come into contact with the skin, the eyes or clothing.
- Consult a doctor immediately if brake fluid has been swallowed.
- Rinse the affected area with plenty of water in the event of contact with the skin.
- Rinse eyes thoroughly with water immediately and consult a doctor if brake fluid comes into contact with the eyes.
- If brake fluid spills on to your clothing, change the clothing.



Warning

Danger of accidents Old brake fluid reduces the braking effect.

- Make sure that brake fluid for the front and rear brake is changed in accordance with the service schedule. (Your authorized KTM workshop will be glad to help.)



Note

Environmental hazard Hazardous substances cause environmental damage.

- Dispose of oils, grease, filters, fuel, cleaning agents, brake fluid, etc., correctly and in compliance with the applicable regulations.



Info

Never use DOT 5 brake fluid. It is silicone-based and purple in color. Oil seals and brake lines are not designed for DOT 5 brake fluid.

Avoid contact between brake fluid and painted parts. Brake fluid corrodes paint.

Only use clean brake fluid from a sealed container.

Preparatory work

- Check that the brake linings of the front brake are secured. (📖 p. 81)

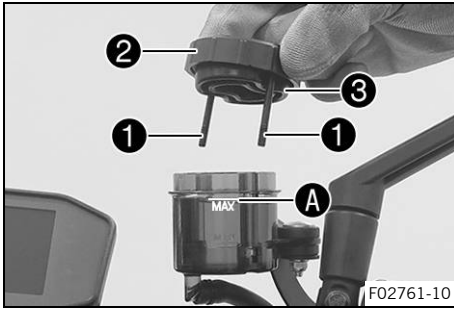

Main work

- Move the brake fluid reservoir mounted on the handlebar to a horizontal position.
- Remove screws ①.
- Take off cover ② with membrane ③.
- Add brake fluid up to the **MAX** marking A.

Brake fluid DOT 4 / DOT 5.1 (📖 p. 136)

- Position cover ② with membrane ③.
- Mount and tighten screws ①.

Guideline

Brake fluid reservoir cover, front	-	0.7 Nm (0.52 lbf ft)
------------------------------------	---	-------------------------

i Info
Use water to immediately clean up any brake fluid that has overflowed or spilled.

14.5 Checking that the brake linings of the front brake are secured

Warning
Danger of accidents Worn-out brake linings reduce the braking effect.
- Ensure that worn-out brake linings are replaced immediately. (Your authorized KTM workshop will be glad to help.)

Warning
Danger of accidents Damaged brake discs reduce the braking effect.
If the brake linings are not changed in time, the brake lining carriers grind against the brake disc. As a consequence, the braking effect is greatly reduced and the brake discs are destroyed.
- Check the brake linings regularly.

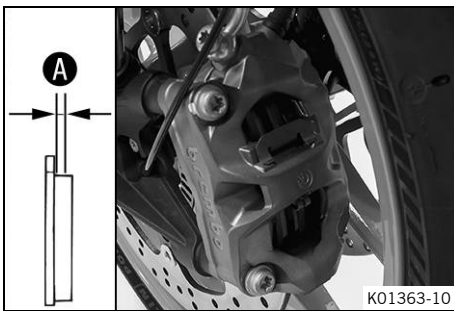

- Check the brake linings for lining thickness A.

Minimum thickness A $\geq 1 \text{ mm } (\geq 0.04 \text{ in})$

- » If it is less than the minimum thickness:
 - Change the brake linings of the front brake. 🛠️
- Check the brake linings for damage and cracking.
 - » If there is damage or cracking:
 - Change the brake linings of the front brake. 🛠️
- Check that the brake linings are secured.
 - » If the brake linings are not secured correctly:
 - Secure brake linings, replace with new parts if necessary.

14.6 Checking the free travel of the foot brake lever



Warning

Danger of accidents The brake system fails in the event of overheating.

If there is no free travel on the foot brake lever, pressure builds up in the brake system on the rear brake.

- Set the free travel on the foot brake lever in accordance with the specification.

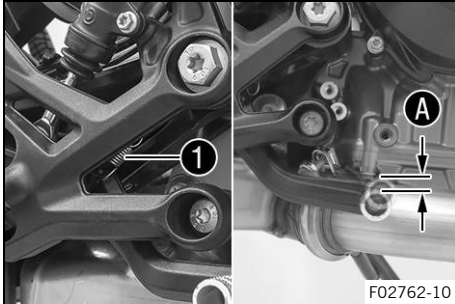

- Detach spring ①.
- Move the foot brake lever back and forth between the end stop and the contact to the foot brake cylinder piston and check free travel ②.

Guideline

Free travel at foot brake lever	3 ... 5 mm (0.12 ... 0.2 in)
---------------------------------	------------------------------

- » If the free travel does not match the specification:
 - Adjust the basic position of the foot brake lever. 🛠️ (📖 p. 46)
- Attach spring ①.

14.7 Checking the rear brake fluid level



Warning

Danger of accidents An insufficient brake fluid level will cause the brake system to fail.

If the brake fluid level drops below the **MIN** marking, the brake system is leaking or the brake linings are worn down.

- Check the brake system and do not continue riding until the problem is eliminated. (Your authorized KTM workshop will be glad to help.)



Warning

Danger of accidents Old brake fluid reduces the braking effect.

- Make sure that brake fluid for the front and rear brake is changed in accordance with the service schedule. (Your authorized KTM workshop will be glad to help.)

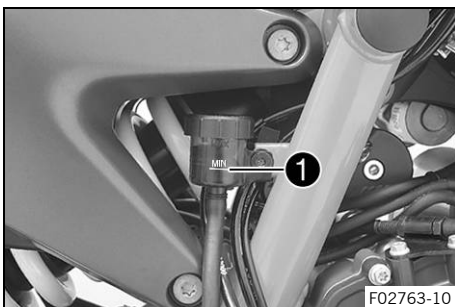

- Stand the vehicle upright.
- Check the brake fluid level in the brake fluid reservoir.
 - » If the fluid level reaches the **MIN** marking ①:
 - Add rear brake fluid. 🛠️ (📖 p. 83)

14.8 Adding rear brake fluid ↩



Warning

Danger of accidents An insufficient brake fluid level will cause the brake system to fail.

If the brake fluid level drops below the **MIN** marking, the brake system is leaking or the brake linings are worn down.

- Check the brake system and do not continue riding until the problem is eliminated. (Your authorized KTM workshop will be glad to help.)



Warning

Skin irritation Brake fluid causes skin irritation.

- Keep brake fluid out of the reach of children.
- Wear suitable protective clothing and safety glasses.
- Do not allow brake fluid to come into contact with the skin, the eyes or clothing.
- Consult a doctor immediately if brake fluid has been swallowed.
- Rinse the affected area with plenty of water in the event of contact with the skin.
- Rinse eyes thoroughly with water immediately and consult a doctor if brake fluid comes into contact with the eyes.
- If brake fluid spills on to your clothing, change the clothing.



Warning

Danger of accidents Old brake fluid reduces the braking effect.

- Make sure that brake fluid for the front and rear brake is changed in accordance with the service schedule. (Your authorized KTM workshop will be glad to help.)



Note

Environmental hazard Hazardous substances cause environmental damage.

- Dispose of oils, grease, filters, fuel, cleaning agents, brake fluid, etc., correctly and in compliance with the applicable regulations.



Info

Never use DOT 5 brake fluid. It is silicone-based and purple in color. Oil seals and brake lines are not designed for DOT 5 brake fluid.

Avoid contact between brake fluid and painted parts. Brake fluid attacks paint.

Only use clean brake fluid from a sealed container.

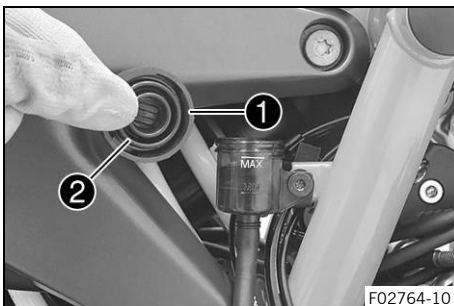

Preparatory work

- Check that the brake linings of the rear brake are secured. (📖 p. 84)

Main work

- Stand the vehicle upright.
- Remove screw cap ① with insert and membrane ②.
- Add brake fluid up to the **MAX** marking.

Brake fluid DOT 4 / DOT 5.1 (📖 p. 136)

- Mount and tighten screw cap with insert and membrane.



Info

Clean up overflowed or spilled brake fluid immediately with water.

14.9 Checking that the brake linings of the rear brake are secured



Warning

Danger of accidents Worn-out brake linings reduce the braking effect.

- Ensure that worn-out brake linings are replaced immediately. (Your authorized KTM workshop will be glad to help.)



Warning

Danger of accidents Damaged brake discs reduce the braking effect.

If the brake linings are not changed in time, the brake lining carriers grind against the brake disc. As a consequence, the braking effect is greatly reduced and the brake discs are destroyed.

- Check the brake linings regularly.

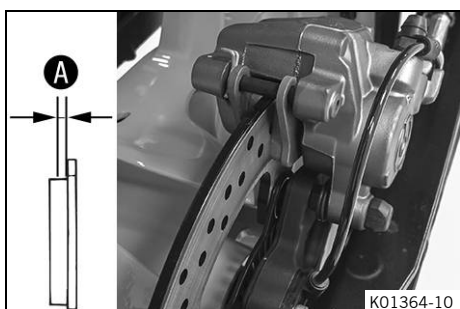

- Check the brake linings for lining thickness **A**.

Minimum thickness A	$\geq 1 \text{ mm } (\geq 0.04 \text{ in})$
----------------------------	---

- » If it is less than the minimum thickness:
 - Change the rear brake linings. 🛠️
- Check the brake linings for damage and cracking.
 - » If there is damage or cracking:
 - Change the rear brake linings. 🛠️
- Check that the brake linings are secured.
 - » If the brake linings are not secured correctly:
 - Secure brake linings, replace with new parts if necessary.

15.1 Removing the front wheel

Preparatory work

- Raise the motorcycle with the rear lifting gear. (p. 68)
- Lift the motorcycle with the front lifting gear. (p. 68)

Main work

- Remove screw ① and pull wheel speed sensor ② out of the hole.
- Remove screws ③.
- Press back the brake linings by slightly tilting the left brake caliper laterally on the brake disc. Pull the left brake caliper carefully back from the brake disc and hang to the side.

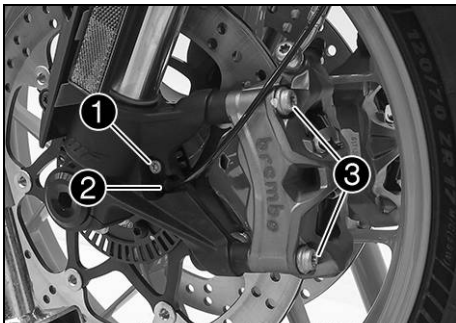

i Info
Do not operate the hand brake lever if the brake caliper has been removed.

- Remove screws ④.
- Press back the brake linings by slightly tilting the right brake caliper laterally on the brake disc. Pull the right brake caliper carefully back from the brake disc and hang to the side.

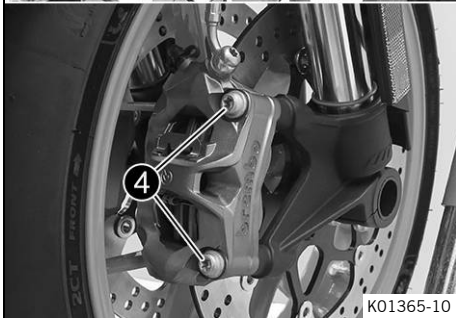

i Info
Do not operate the hand brake lever if the brake caliper has been removed.

- Loosen screw ⑤ by several rotations.
- Loosen screws ⑥.
- Press on screw ⑤ to push the wheel spindle out of the axle clamp.
- Remove screw ⑤.

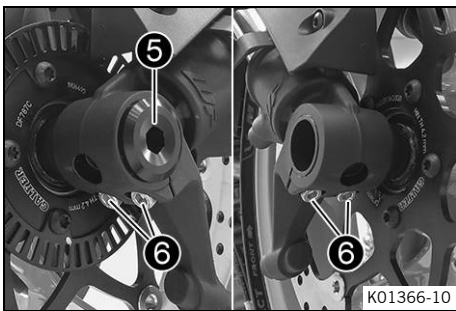

⚠ Warning
Danger of accidents Damaged brake discs reduce the braking effect.
- Always lay the wheel down in such a way that the brake discs are not damaged.

- Hold the front wheel and remove the wheel spindle. Take the front wheel out of the fork.
- Remove spacers ⑦.

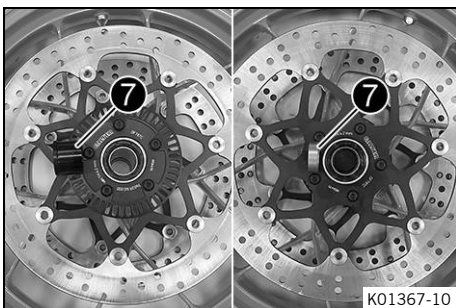

15.2 Installing the front wheel ↩



Warning

Danger of accidents Oil or grease on the brake discs reduces the braking effect.

- Always keep the brake discs free of oil and grease.
- Clean the brake discs with brake cleaner when necessary.

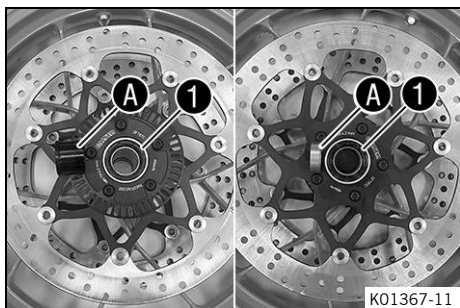

- Check the wheel bearing for damage and wear.
 - » If the wheel bearing is damaged or worn:
 - Change front wheel bearing. ↩
- Clean and grease shaft seal rings **1** and contact surfaces **A** of the spacers.

Long-life grease (🛢️ p. 138)

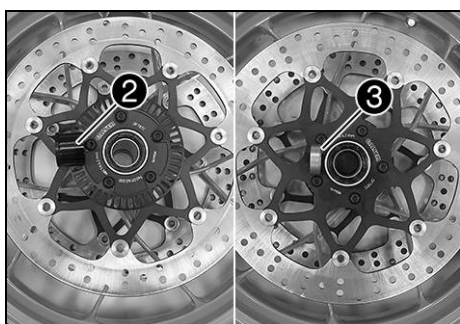

- Insert wide spacer **2** on the left in the direction of travel.
- Insert narrow spacer **3** on the right in the direction of travel.



Info

Arrow **B** indicates the direction of travel of the front wheel.

The wheel speed sensor wheel is on the left viewed in the direction of travel.

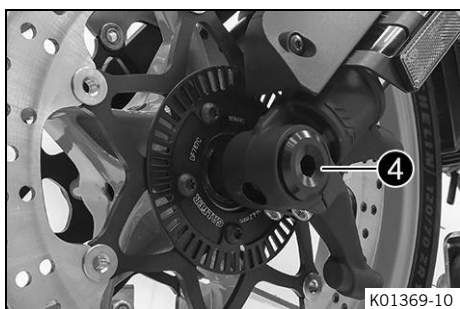
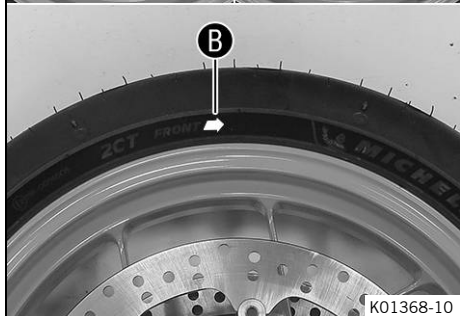

- Clean screw **4** and the wheel spindle.
- Grease wheel spindle lightly.

Long-life grease (🛢️ p. 138)

- Jack up the front wheel into the fork, position it, and insert the wheel spindle.
- Mount and tighten screw **4**.

Guideline

Screw, front wheel spindle	M25x1.5	45 Nm (33.2 lbf ft) Thread greased
----------------------------	---------	---------------------------------------

i Tip
 Temporarily tighten one of the axle clamp screws so that the axle does not rotate with it.
 Loosen the axle clamp screw again before compression to allow the fork legs to align.

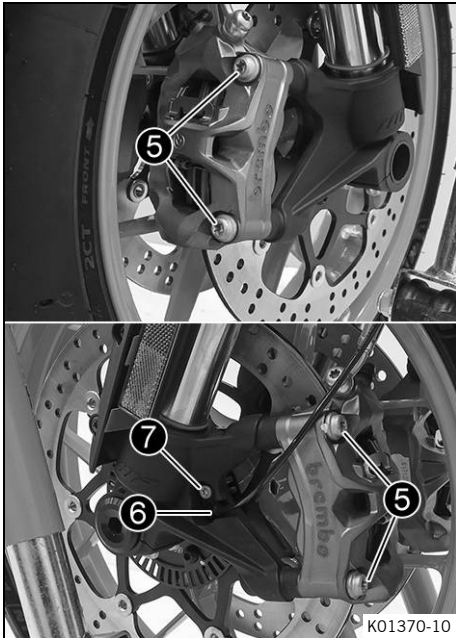

- Position both brake calipers.
- ✓ The brake linings are correctly positioned.
- Mount screws **5** on both sides but do not tighten yet.

Guideline

Screw, front brake caliper	M10x1.25	45 Nm (33.2 lbf ft) Loctite®243™
----------------------------	----------	--

- Operate the hand brake lever repeatedly until the brake linings are in contact with the brake disc and there is a pressure point. Secure the hand brake lever in the activated position.

✓ The brake calipers straighten.

- Tighten screws **5** on both sides.

Guideline

Screw, front brake caliper	M10x1.25	45 Nm (33.2 lbf ft) Loctite®243™
----------------------------	----------	--

- Position wheel speed sensor **6** in the hole.
- Mount and tighten screw **7**.

Guideline

Screw, wheel speed sensor	M6	6 Nm (4.4 lbf ft)
---------------------------	----	-------------------

- Remove the locking piece of the hand brake lever.
- Take the motorcycle off the front lifting gear. (📖 p. 69)
- Remove the rear of the motorcycle from the lifting gear. (📖 p. 68)
- Operate the front brake and compress the fork a few times firmly.

✓ The fork legs straighten.

- Tighten screws **8**.

Guideline

Screw, fork stub	M8	15 Nm (11.1 lbf ft)
------------------	----	---------------------

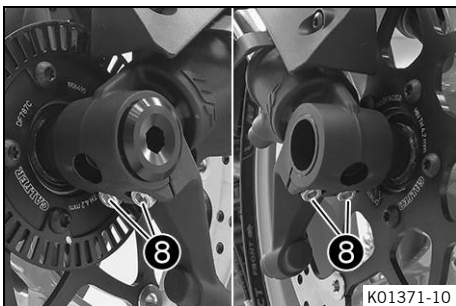

15.3 Removing the rear wheel 🛠️

Preparatory work

- Raise the motorcycle with the rear lifting gear. (📖 p. 68)

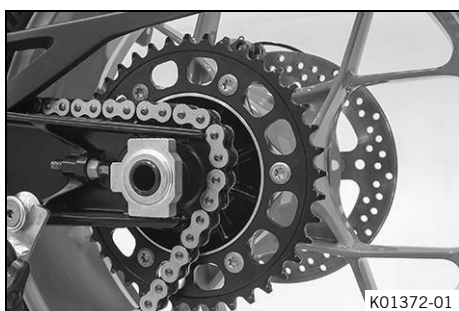
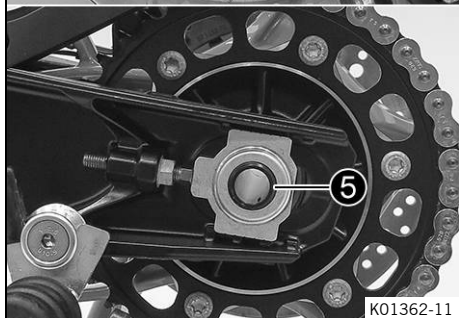
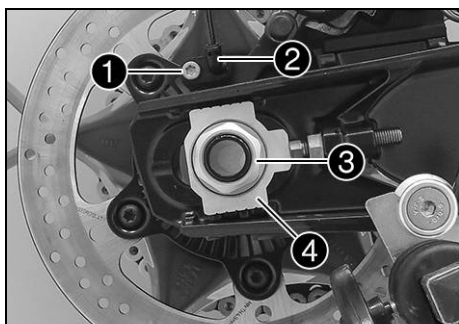

Main work

- Manually press the brake caliper toward the brake disc to push back the brake piston.
- Remove screw ① and pull wheel speed sensor ② out of the hole.
- Remove nut ③. Take off chain adjuster ④.
- Pull out wheel spindle ⑤ far enough to allow the rear wheel to be pushed forward.

- Push the rear wheel forward as far as possible. Remove the chain from the rear sprocket.

i Info
Cover the components to protect them against damage.

- Hold the rear wheel and remove the wheel spindle.
- Pull the rear wheel back until the brake caliper bracket is suspended freely between the brake disc and rim.

! Warning
Danger of accidents Damaged brake discs reduce the braking effect.

- Always lay the wheel down in such a way that the brake disc is not damaged.

- Take the rear wheel out of the link fork.

i Info
Do not operate the foot brake lever when the rear wheel is removed.

15.4 Installing the rear wheel ↗

! Warning
Danger of accidents Oil or grease on the brake discs reduces the braking effect.

- Always keep the brake discs free of oil and grease.
- Clean the brake discs with brake cleaner when necessary.



Warning

Danger of accidents There is no braking effect to start with at the rear brake after installing the rear wheel.

- Actuate the foot brake several times before going on a ride until you can feel a firm pressure point.

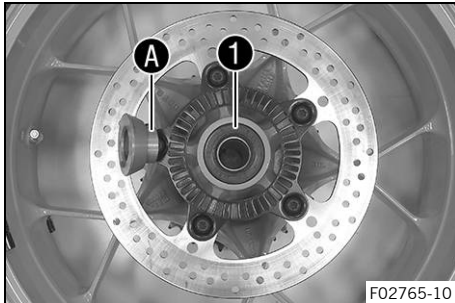

Main work

- Check the rear hub damping rubber pieces. 🛠️ (📖 p. 90)
- Check the wheel bearing for damage and wear.
 - » If the wheel bearing is damaged or worn:
 - Change the rear wheel bearing. 🛠️
- Remove spacer.
- Clean and grease shaft seal ring ① and contact surface ① of the spacer.

Long-life grease (📖 p. 138)

- Insert a spacer.
- Clean and grease the thread of the wheel spindle and nut.

Long-life grease (📖 p. 138)

- Clean and grease the wheel spindle.

Long-life grease (📖 p. 138)

- Clean the contact areas on the brake caliper bracket and link fork.

- Engage the thrust bearing of brake caliper bracket ② and the link fork.
- Jack up the rear wheel into the link fork, position it, and insert the wheel spindle.

✓ The brake linings are correctly positioned.

- Place the chain on the sprocket.
- Position chain adjuster ②. Mount nut ③, but do not tighten it yet.

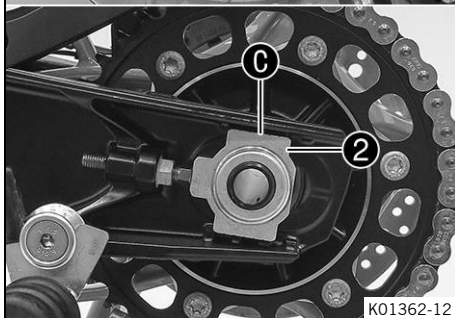
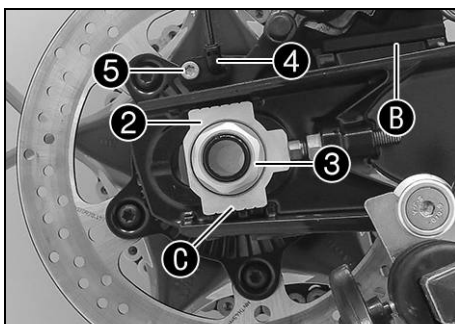

Info

Mount the left and right chain adjusters in the same position.

- Make sure that chain adjusters ② are fitted correctly on the adjusting screws. Tighten nut ③.

Guideline

In order for the rear wheel to be correctly aligned, the markings on the left and right chain adjusters must be in the same position relative to reference markings ③.

Nut, rear wheel spindle	M25x1.5	90 Nm (66.4 lbf ft) Thread and contact area of wheel spindle greased
-------------------------	---------	---

- Position wheel speed sensor ④ in the hole.
- Mount and tighten screw ⑤.

Guideline

Screw, wheel speed sensor	M6	6 Nm (4.4 lbf ft)
---------------------------	----	-------------------

- Operate the foot brake lever repeatedly until the brake linings are in contact with the brake disc and there is a pressure point.

Finishing work

- Check the chain tension. (📖 p. 73)
- Remove the rear of the motorcycle from the lifting gear. (📖 p. 68)

15.5 Checking the rear hub damping rubber pieces 🛠️

i Info

The engine power is transmitted from the rear sprocket to the rear wheel via the 6 damping rubber pieces. They eventually wear out during operation. If the damping rubber pieces are not changed in time, the rear sprocket carrier and the rear hub will be damaged.

Preparatory work

- Raise the motorcycle with the rear lifting gear. (📖 p. 68)
- Remove the rear wheel. 🛠️ (📖 p. 87)

Main work

- Check bearing **1**.
 - » If the bearing is damaged or worn:
 - Change the bearing of the rear sprocket carrier. 🛠️
- Check the damping rubber pieces **2** of the rear hub for damage and wear.
 - » If the damping rubber pieces of the rear hub are damaged or worn:
 - Change all the damping rubber pieces of the rear hub.
- Lay the rear wheel on a workbench with the rear sprocket facing upwards and insert the wheel spindle in the hub.
- To check play **A**, hold the rear wheel tight and try to turn the rear sprocket with your hand.



V01252-10

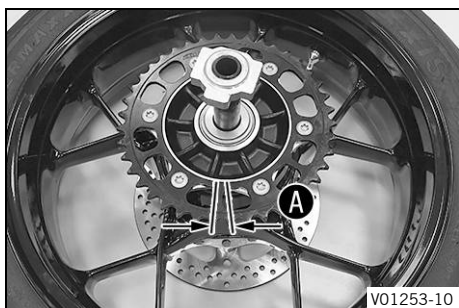

V01253-10

i Info

Measure the play on the outside of the rear sprocket.

Play of damping rubber pieces on rear wheel	≤ 5 mm (≤ 0.2 in)
---	-------------------

- » If clearance **A** is larger than the specified value:
 - Change all the damping rubber pieces of the rear hub. 🛠️

Finishing work

- Install the rear wheel. 🛠️ (📖 p. 88)
- Check the chain tension. (📖 p. 73)
- Remove the rear of the motorcycle from the lifting gear. (📖 p. 68)

15.6 Checking the tire condition



Warning

Danger of accidents If a tire bursts while riding, the vehicle becomes uncontrollable.

- Ensure that damaged or worn tires are replaced immediately. (Your authorized KTM workshop will be glad to help.)



Warning

Danger of crashing Different tire tread patterns on the front and rear wheel impair the handling characteristic.

Different tire tread patterns can make the vehicle significantly more difficult to control.

- Make sure that only tires with a similar tire tread pattern are fitted to the front and rear wheel.



Warning

Danger of accidents Non-approved or non-recommended tires and wheels impact the handling characteristic.

- Only use tires/wheels approved by KTM with the corresponding speed index.



Warning

Danger of accidents New tires have reduced road grip.

The contact surface on new tires is not yet roughened.

- Run in new tires with moderate riding and only gradually increase the lean angle.
Run-in distance 200 km (124 mi)



Info

The type, condition, and pressure of the tires all have a major impact on the handling characteristic of the motorcycle.

Worn tires have a negative effect on handling characteristics, especially on wet surfaces.

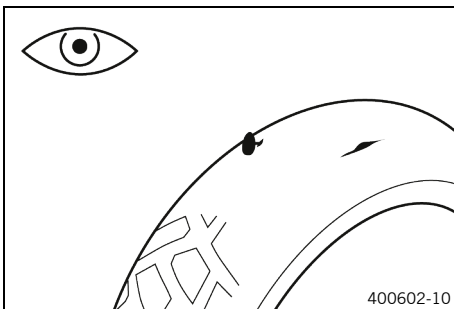

- Check the front and rear tires for cuts, run-in objects, and other damage.
 - » If the tires have cuts, run-in objects, or other damage:
 - Change the tires. 🛠️
- Check the tread depth.



Info

Adhere to the legally required minimum tread depth.

Minimum tread depth	$\geq 2 \text{ mm } (\geq 0.08 \text{ in})$
---------------------	---

- » If the tread depth is less than the minimum tread depth:
 - Change the tires. 🛠️

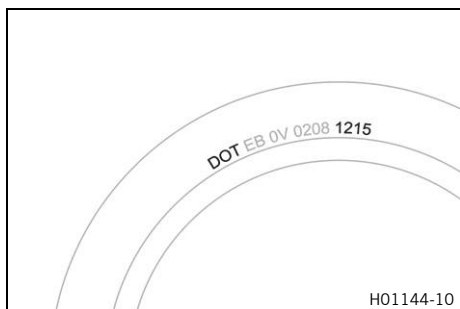

- Check the tire age.



Info

The tire date of manufacture is usually contained in the tire label and is indicated by the last four digits of the **DOT** number. The first two digits indicate the week of manufacture and the last two digits the year of manufacture.

KTM recommends that the tires be changed after 5 years at the latest, regardless of the actual state of wear.

- » If the tires are more than 5 years old:
 - Change the tires. 🛠️

15.7 Checking tire pressure



Info

Low tire pressure leads to abnormal wear and overheating of the tire.

Correct tire pressure ensures optimal riding comfort and maximum tire service life.

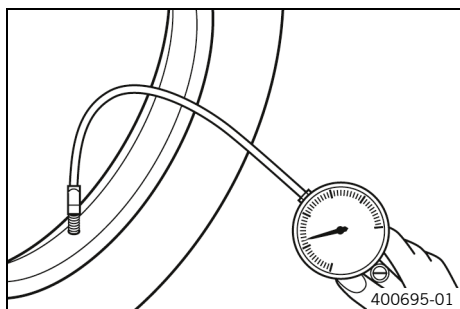

- Remove the protection cap.
- Check the tire pressure when the tires are cold.

Tire pressure when solo	
front	2.3 bar (33 psi)
rear	2.5 bar (36 psi)

Tire pressure with passenger / full payload	
front	2.3 bar (33 psi)
rear	2.6 bar (38 psi)

- » If the tire pressure does not meet specifications:
 - Correct the tire pressure.
- Mount the protection cap.

15.8 Using tire repair spray

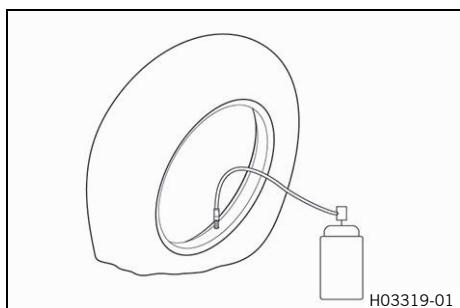

Warning

Danger of accidents Incorrect use of tire repair spray will result in the repaired tire losing pressure.

Tire repair spray cannot be used for all types of damage.

- Observe the instructions and specifications of the manufacturer of the tire repair spray.
- After repairing a tire with tire repair spray, ride slowly and carefully.
- Ride no further than to the nearest workshop and have the tire changed.

Tire repair spray should only be used in an emergency. We recommend transporting the broken down vehicle to the nearest workshop instead of using tire repair spray.

(Option: With TPMS)

Note

Material damage Tire repair spray damages the tire pressure sensor.

- Note that after using tire repair spray, the tire pressure sensor may need to be replaced.
-

16.1 Daytime running light (DRL)

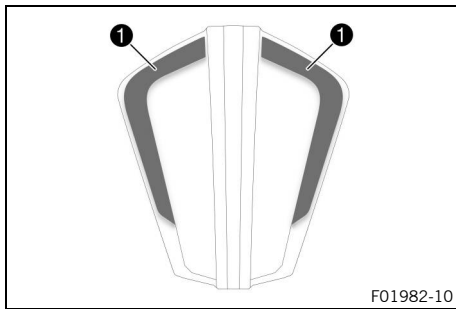

Warning

Danger of accidents When visibility is poor, the daytime running light is not a substitute for the low beam.

Automatic switching between the daytime running light and low beam may only be partially available when visibility is significantly impaired due to fog, snow or rain.

- Ensure that the appropriate type of lighting is always selected.
- If necessary switch off the daytime running lights using the menu before going on a ride or when stopped so that the low beam is switched on permanently.
- Make sure that the daytime running light is deactivated with the diagnostics tool when the menu item is not available, but the low beam is required. (Your authorized KTM workshop will be glad to help.)
- Note the legal regulations regarding the daytime running light.

The daytime running light (DRL) is integrated in the main headlight.

The daytime running light (DRL) must only be switched on when visibility conditions are good.

Activate the daytime running light (DRL) in the combination instrument.

This is controlled by the ambient light sensor in the combination instrument. When visibility conditions are good, the low beam is switched off and the daytime running light is switched on.



Info

The position light **1** lights up with all types of lighting.

16.2 Removing the 12-V battery



Warning

Risk of injury Battery acid and battery gases cause serious chemical burns.

- Keep 12 V batteries out of the reach of children.
- Wear suitable protective clothing and safety glasses.
- Avoid contact with battery acid and battery gases.
- Keep sparks or open flames away from the 12 V battery.
- Only charge 12 V batteries in well-ventilated rooms.
- Rinse the affected area immediately with plenty of water in the event of contact with the skin.
- Rinse eyes with water for at least 15 minutes and consult a doctor immediately if battery acid and battery gases get into the eyes.

Preparatory work

- Remove the passenger seat. (📖 p. 70)

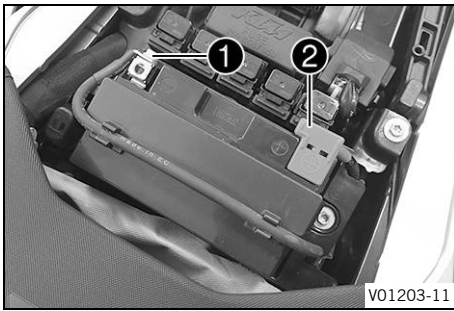

Main work

- Disconnect negative cable **1** from the 12-V battery.
- Remove positive terminal cover **2**.

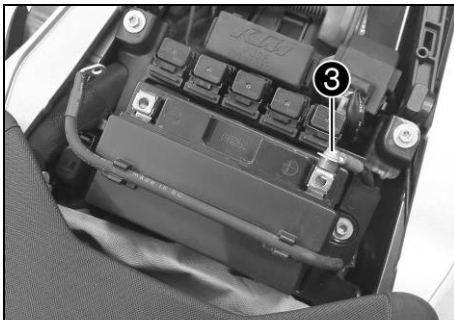

- Disconnect positive cable **3** from the 12-V battery.
- Take negative cable out of holders on the battery support bracket.
- Remove screw **4**.
- Pull battery support bracket **5** to the side.
- Pull the 12-V battery upwards and out of the battery compartment.

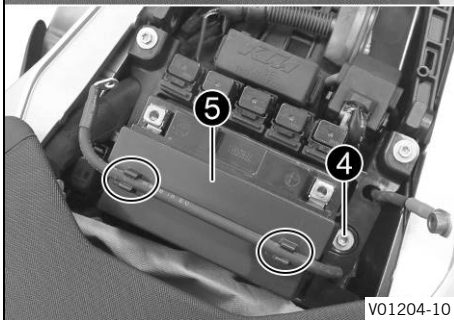

16.3 Installing the 12-V battery

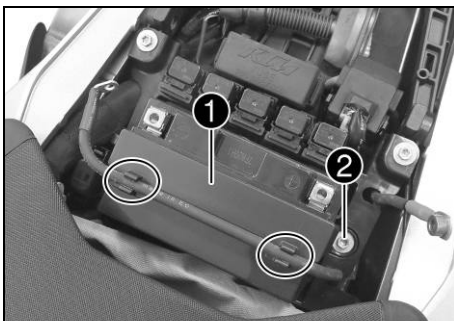

Main work

- Position the 12-V battery in the battery compartment.

12 V battery (HTZ12A-BS) (p. 129)

✓ The battery terminals face opposite the direction of travel.

- Position battery support bracket **1**.
- Mount and tighten screw **2**.

Guideline

Remaining screws, chassis	M6	10 Nm (7.4 lbf ft)
---------------------------	----	--------------------

- Connect positive cable **3** to the 12 V battery.

Guideline

Screw, battery terminal	M6x20	4.5 Nm (3.32 lbf ft)
-------------------------	-------	----------------------



Info

Make sure the cable lies in the recess provided for this next to the battery compartment.

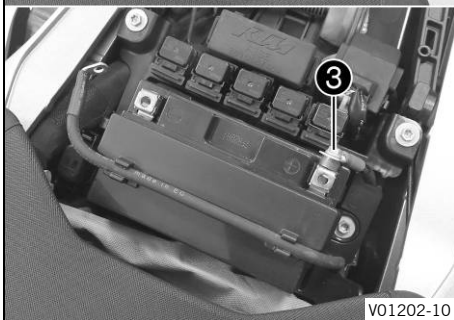

- Hook negative cable into the holders on the battery support bracket.

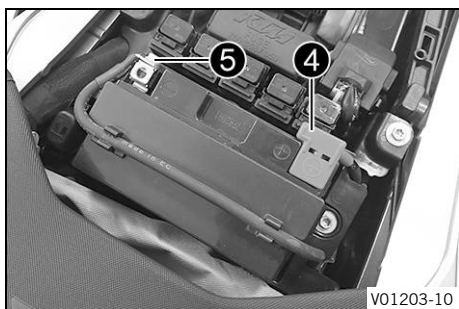

- Mount positive terminal cover ④.
- Connect negative cable ⑤ to the 12 V battery.

Guideline

Screw, battery terminal	M6x12	4.5 Nm (3.32 lbf ft)
-------------------------	-------	-------------------------

Finishing work

- Mount the passenger seat. (📖 p. 71)
- Set the time and date.

16.4 Charging the 12-V battery ↗



Warning

Risk of injury Battery acid and battery gases cause serious chemical burns.

- Keep 12 V batteries out of the reach of children.
- Wear suitable protective clothing and safety glasses.
- Avoid contact with battery acid and battery gases.
- Keep sparks or open flames away from the 12 V battery.
- Only charge 12 V batteries in well-ventilated rooms.
- Rinse the affected area immediately with plenty of water in the event of contact with the skin.
- Rinse eyes with water for at least 15 minutes and consult a doctor immediately if battery acid and battery gases get into the eyes.



Note

Environmental hazard 12 V batteries contain environmentally hazardous materials.

- Do not dispose of 12 V batteries as household waste.
- Dispose of 12 V batteries at a collection point for used batteries.



Note

Environmental hazard Hazardous substances cause environmental damage.

- Dispose of oils, grease, filters, fuel, cleaning agents, brake fluid, etc., correctly and in compliance with the applicable regulations.



Info

Even when there is no load on the 12-V battery, it discharges steadily each day.

The charging level and the method of charging are very important for the service life of the 12-V battery. Rapid recharging with a high charging current shortens the service life of the battery.

If the charging current, charging voltage, or charging time is exceeded, electrolyte escapes through the safety valves. This reduces the capacity of the 12-V battery.

If the 12-V battery is depleted from starting the vehicle repeatedly, the battery must be charged immediately.

If the 12-V battery is left in a discharged state for an extended period, it will become deeply discharged and sulfating occurs, destroying the battery.

The 12-V battery is maintenance-free. The acid level does not have to be checked.

Preparatory work

- Remove the passenger seat. (📖 p. 70)

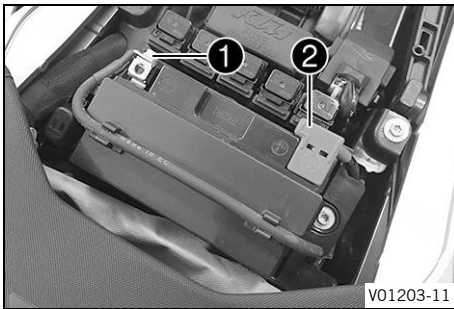

V01203-11

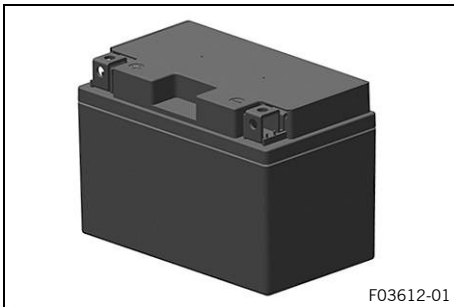

F03612-01

Main work

- Disconnect negative cable ① from the 12 V battery to avoid damaging the onboard electronics.
- Remove positive terminal cover ②.

- Connect a battery charger to the 12-V battery. Connect the battery charger to the mains connection.

Battery charger (58429074200)

It is impossible to overcharge the 12-V battery using this battery charger.

This battery charger is not suitable for lithium-ion batteries.



Info

Charge the 12-V battery to a maximum of 10 % of the capacity specified on the battery housing.

- Disconnect the battery charger from the mains connection and the 12-V battery after charging.

Guideline

The charging current, charging voltage, and charging time must not be exceeded.

Recharge the 12-V battery regularly when the motorcycle is not being used	3 months
---	----------

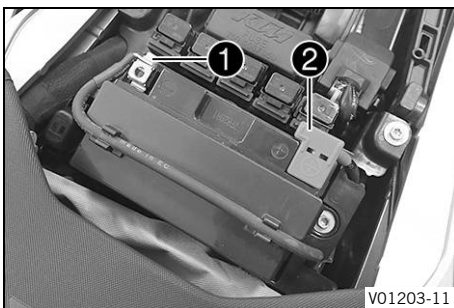

V01203-11

- Mount positive terminal cover ②.
- Connect negative cable ① to the 12 V battery.

Finishing work

- Mount the passenger seat. (📖 p. 71)
- Set time and date.



16.5 Changing the main fuse



Warning

Fire hazard Incorrect fuses overload the electrical system.

- Only use fuses with the required ampere value.
- Do not bypass or repair fuses.



Info

The main fuse protects all electrical power consumers of the vehicle. The main fuse is under the passenger seat.

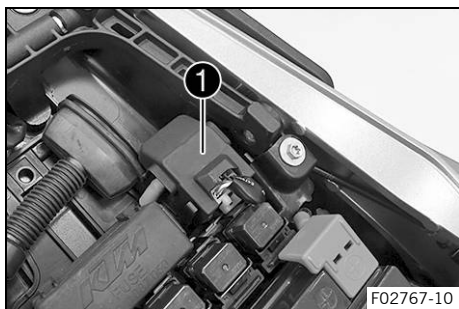
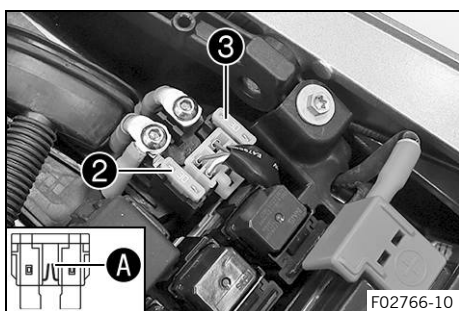
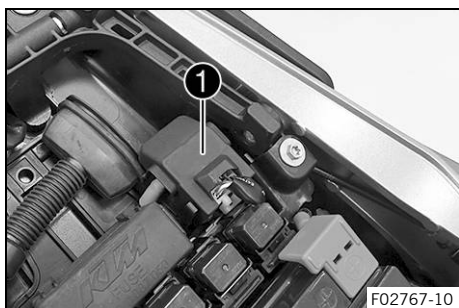

Preparatory work

- Remove the passenger seat. (📖 p. 70)

Main work

- Remove protection cap ①.

- Remove faulty main fuse ②.



Info

A faulty fuse has a burned-out fuse wire **A**.

A spare fuse **③** is located in the starter relay.

- Insert a new main fuse.

Fuse (58011109130) (📖 p. 129)



Tip

Insert a new spare fuse into the starter relay to have it available when needed.

- Mount protection cap ①.

Finishing work

- Mount the passenger seat. (📖 p. 71)
- Set time and date.

16.6 Changing the ABS fuses



Warning

Fire hazard Incorrect fuses overload the electrical system.

- Only use fuses with the required ampere value.
- Do not bypass or repair fuses.



Info

Two fuses for the ABS are located under the passenger seat. These fuses protect the return pump and the hydraulic unit of the ABS. The third fuse, which protects the ABS control unit, is located in the fuse box.

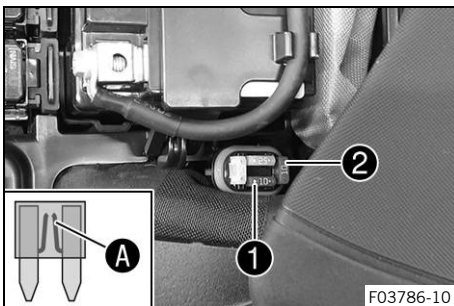

Preparatory work

- Remove the passenger seat. (📖 p. 70)

To change the fuse of the ABS hydraulic unit:

- Remove the protection cap and fuse ①.



Info

A faulty fuse has a burned-out fuse wire **A**.

- Insert the spare fuse with the correct rating.

Fuse (75011088010) (📖 p. 129)



Tip

Insert spare fuse ② in the fuse box so that it is available if needed.

- Mount the protection cap.

To change the fuse of the ABS return pump:

- Remove the protection cap and fuse ③.



Info

A faulty fuse has a burned-out fuse wire **A**.

- Insert the spare fuse with the correct rating.

Fuse (75011088025) (📖 p. 129)



Tip

Insert spare fuse ④ in the fuse box so that it is available if needed.

- Mount the protection cap.

Finishing work

- Mount the passenger seat. (📖 p. 71)

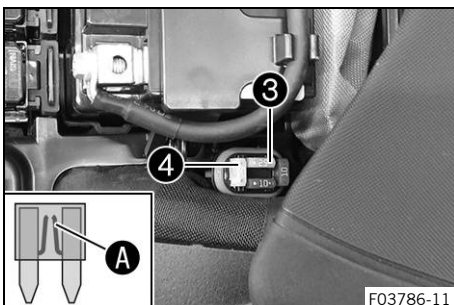

16.7 Changing the fuses of individual electrical power consumers



Warning

Fire hazard Incorrect fuses overload the electrical system.

- Only use fuses with the required ampere value.
- Do not bypass or repair fuses.



Info

The fuse box containing the fuses of individual electrical power consumers is located under the seat.

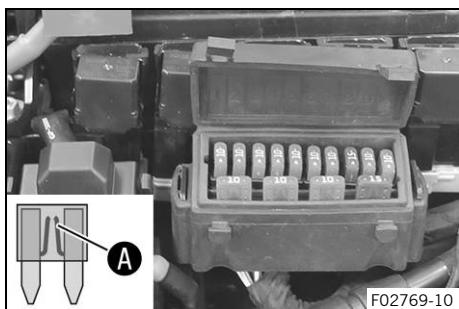
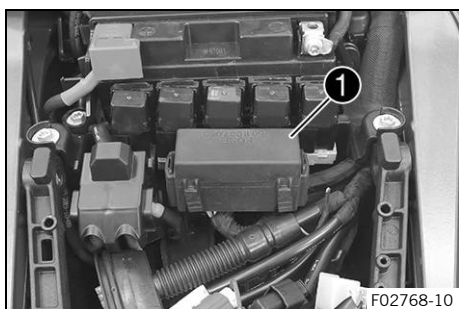

Preparatory work

- Remove the passenger seat. (📖 p. 70)

Main work

- Open fuse box cover ①.

- Remove the faulty fuse.

Guideline

Fuse 1 - 10 A - ignition
Fuse 2 - 10 A - ignition, engine control unit, electronic fuel injection, fuel vapor retention system, lambda sensor, immobilizer/alarm system
Fuse 3 - 10 A - fuel pump
Fuse 4 - 10 A - radiator fan
Fuse 5 - 10 A - horn, combination instrument, brake light
Fuse 6 - 10 A - high beam, low beam, position light, tail light, license plate lamp
Fuse 7 - 10 A - ACC1
Fuse 8 - 15 A - ACC2, HCU (optional)
Fuse 9 - 10 A - ABS control unit, diagnostics connector, 5D sensor, TPMS (function optional)
Fuse 10 - 10 A - light control unit
Fuse SPARE - 10 A/15 A - spare fuses



Info

A faulty fuse has a burned-out fuse wire ①.

- Insert the spare fuse with the correct rating.

Fuse (75011088010) (📖 p. 129)

Fuse (75011088015) (📖 p. 129)

i Tip
Put a spare fuse in the fuse box so that it is available if needed.

- Check the function of the electrical power consumer.
- Close the fuse box cover.

Finishing work

- Mount the passenger seat. (📖 p. 71)



16.8 Loosening the headlight mask with the headlight

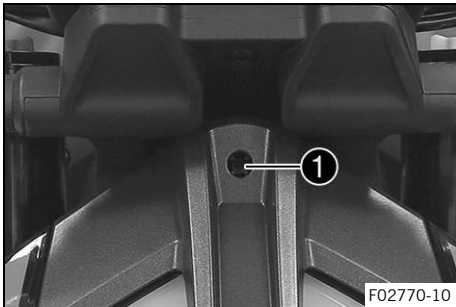

- Completely unscrew adjusting screw ①.

i Info
The adjusting screw is fastened to the headlight mask by a ball head holder.
Do not pull the adjusting screw out of the ball head adjuster.

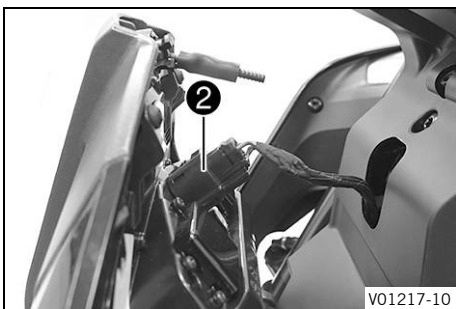

- Swivel the headlight mask forwards slightly and disconnect connector ②.
- Swivel the headlight mask all the way forwards.



16.9 Mounting the headlight mask with the headlight

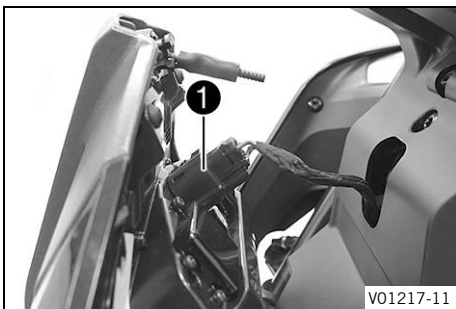

Main work

- Swivel the headlight mask up.
- Plug in connector ①.
- Position the headlight mask.

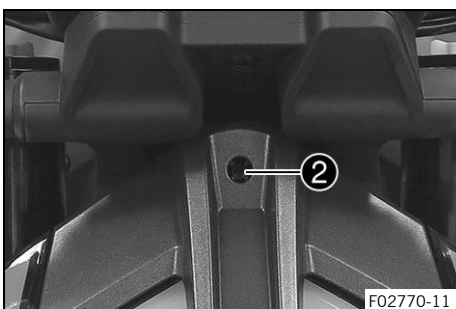

- Mount adjusting screw ②.

Finishing work

- Check the headlight setting. (📖 p. 103)

16.10 Removing the cover of the headlight mask rack



Info

The cover of the headlight mask rack must be removed in order to gain access to the ACC1 and ACC2 power supply.

Preparatory work

- Loosen the headlight mask with the headlight. (📖 p. 101)

Main work

- Remove screws ①.
- Remove screws ②.

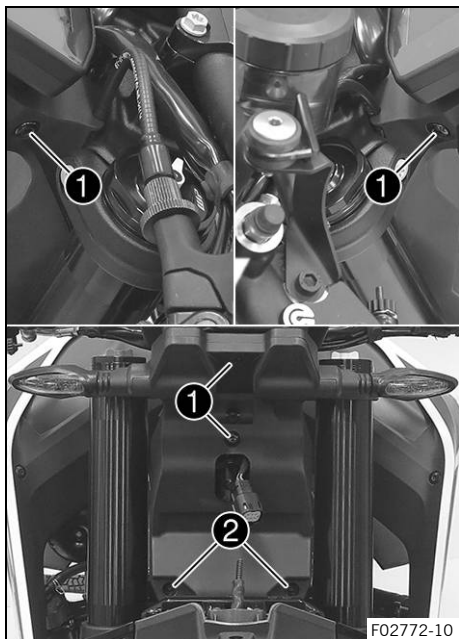

- Hold turn signal in the area **A** and carefully press against the direction of travel.
 - ✓ The cover is detached as illustrated.
- Repeat the operation on the opposite side.
- Take off the cover.

16.11 Installing the cover of the headlight mask rack

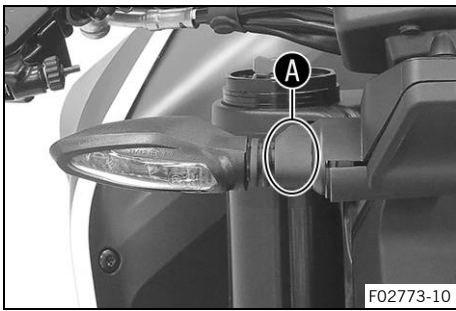

Main work

- Position cover by guiding the plug-in connector of the headlight through the opening.
- Hold turn signal in the area **A** and carefully press against the direction of travel, while pressing the cover tight at the same time.
- ✓ The cover engages with an audible click.
- Repeat the operation on the opposite side.

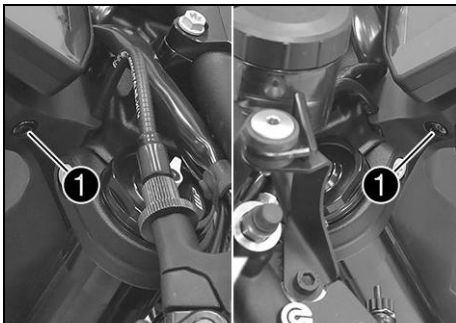

- Mount and tighten screws **1**.

Guideline

Remaining screws, chassis	M5	5 Nm (3.7 lbf ft)
---------------------------	----	-------------------

- Mount and tighten screws **2**.

Guideline

Screw, headlight	EJOT PT® K50x14	4 Nm (3 lbf ft)
------------------	---------------------------	-----------------

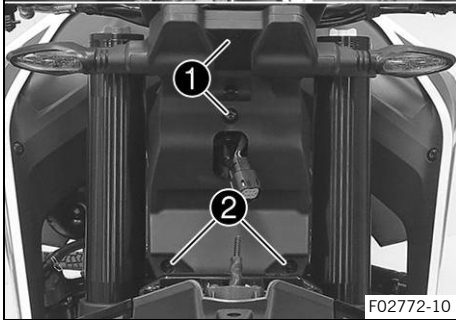

Finishing work

- Mount the headlight mask with the headlight. (📖 p. 101)
- Check the headlight setting. (📖 p. 103)



16.12 Checking the headlight setting

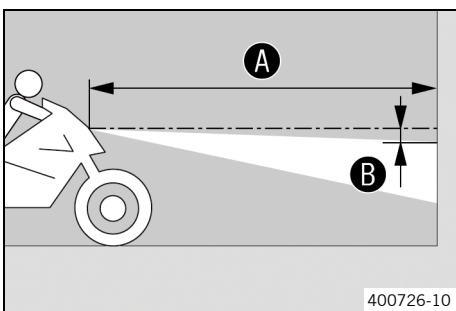

- Position the vehicle upright on a horizontal surface in front of a light wall and make a marking at the height of the center of the low beam headlight.

- Make another mark at a distance **B** under the first marking.

Guideline

Distance B	5 cm (2 in)
-------------------	-------------

- Position the vehicle perpendicular to the wall at a distance **A** from the wall and switch on the low beam.

Guideline

Distance A	5 m (16 ft)
-------------------	-------------

- The rider now mounts the motorcycle with luggage and passenger if applicable.
- Check the headlight setting.

The light-dark boundary must be exactly on the lower marking when the motorcycle is ready to be operated with the rider mounted along with any luggage and a passenger if applicable.

- » If the boundary between light and dark does not meet specifications:
 - Adjust the headlight range. (📖 p. 104)

16.13 Adjusting the headlight range

Preparatory work

- Check the headlight setting. (📖 p. 103)

Main work

- Turn adjusting screw ❶ to adjust the headlight range.

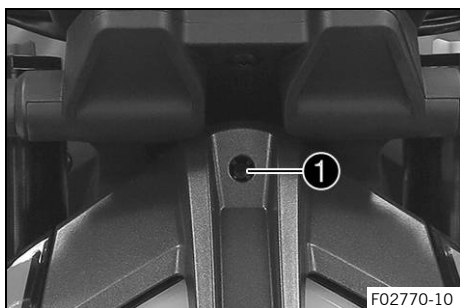

Info

Turn clockwise to increase the headlight range; turn counterclockwise to reduce the headlight range. If you have a payload, you may have to correct the headlight range.

Screw ❶ also secures the headlight. Ensure the screw is always screwed in far enough.

- Set the headlight to marking ❷.

Guideline

The light-dark boundary must lie exactly on lower marking ❷ when the motorcycle is ready to operate with the rider mounted along with any luggage and a passenger, if applicable.

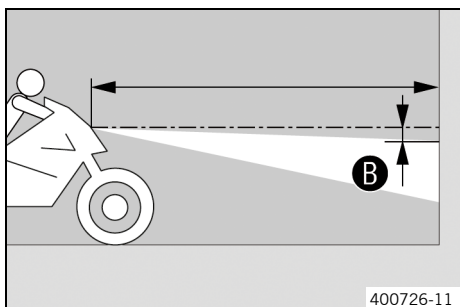

16.14 Diagnostics connector

Diagnostics connector ❶ is located under the passenger seat.

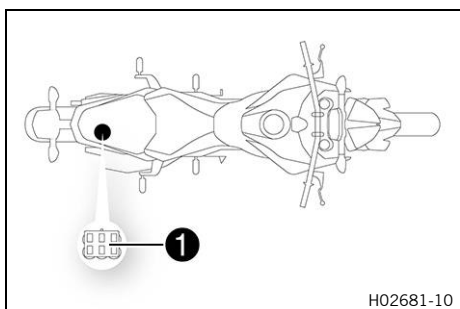

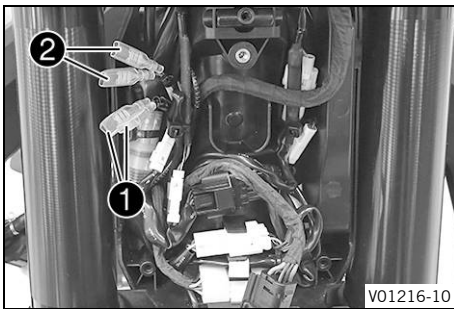
16.15 Front ACC1 and ACC2**Installation location**

- Power supplies ACC1 ① and ACC2 ② front are located under the cover of the headlight mask rack.

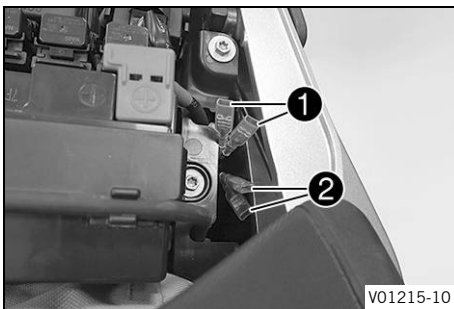
16.16 ACC1 and ACC2 rear**Installation location**

- The rear power supplies ACC1 ① and ACC2 ② are located under the passenger seat next to the battery compartment.

17.1 Cooling system

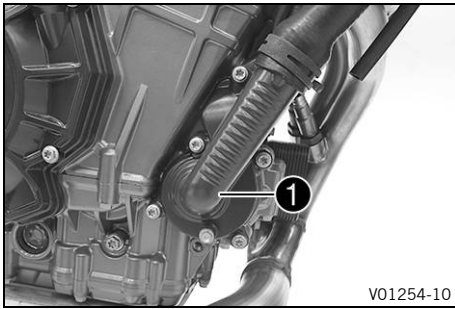

Water pump ① in the engine ensures forced circulation of the coolant.

The pressure resulting from the warming of the cooling system is regulated by a valve in radiator cap ②. Heat expansion causes excess coolant to flow into compensating tank ③. When the temperature falls, this surplus coolant is sucked back into the cooling system. This ensures that operating the vehicle at the specified coolant temperature will not result in a risk of malfunctions.

115 °C (239 °F)

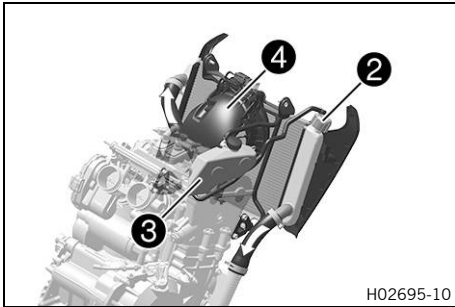

The coolant is cooled by the air stream and a radiator fan ④, which is activated at high temperature.

The lower the speed, the less the cooling effect. Dirty cooling fins also reduce the cooling effect.

17.2 Checking the antifreeze and coolant level



Warning

Danger of scalding During motorcycle operation, the coolant gets very hot and is under pressure.

- Do not open the radiator, the radiator hoses or other cooling system components if the engine or the cooling system are at operating temperature.
- Allow the cooling system and the engine to cool down before you open the radiator, the radiator hoses or other components of the cooling system.
- In the event of scalding, rinse the area affected immediately with lukewarm water.



Warning

Danger of poisoning Coolant is harmful to health.

- Keep coolant out of the reach of children.
- Do not allow coolant to come into contact with the skin, the eyes and clothing.
- Consult a doctor immediately if coolant is swallowed.
- Rinse the affected area immediately with plenty of water in the event of contact with the skin.
- Rinse eyes thoroughly with water and consult a doctor immediately if coolant gets into the eyes.
- Change clothing if coolant spills onto your clothing.

Condition

The engine is cold.

Preparatory work

- Stand the motorcycle upright on a horizontal surface.

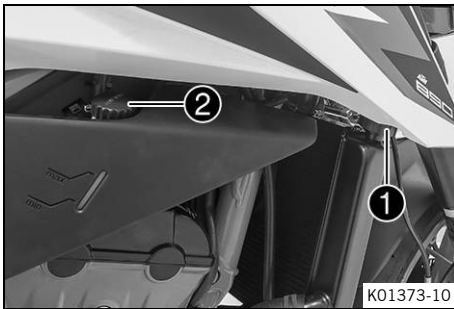

Main work

- Remove radiator cap ① and cap ② of the compensating tank.
- Check the antifreeze in the coolant.

Antifreeze	-25 ... -45 °C (-13 ... -49 °F)
------------	---------------------------------

- » If the antifreeze in the coolant does not match the specified value:
 - Correct the antifreeze in the coolant.
- Check the coolant level in the compensating tank.

The coolant level must be between **MIN** and **MAX**.

- » If the coolant level in the compensating tank is not at the required level, but the tank is not empty:
 - Replenish coolant up to a level between **MIN** and **MAX**.

Coolant (📖 p. 136)

- » If there is no coolant in the compensating tank:
 - Check the cooling system for leaks. 🛠️

i Info

Do not start up the motorcycle!

- Fill/bleed the cooling system. 🛠️ (📖 p. 109)
- Mount cap ② of the compensating tank.
- Check the coolant level in the radiator.

The radiator must be filled completely.

- » If the coolant level does not match the specified value:
 - Check the coolant level and the reason for the loss.
- » If you had to add more coolant than the specified amount:
 - > 0.50 l (> 0.53 qt.)
 - Fill/bleed the cooling system. 🛠️ (📖 p. 109)
- Mount radiator cap ①.



17.3 Checking the coolant level in the compensating tank



Warning

Danger of scalding During motorcycle operation, the coolant gets very hot and is under pressure.

- Do not open the radiator, the radiator hoses or other cooling system components if the engine or the cooling system are at operating temperature.
- Allow the cooling system and the engine to cool down before you open the radiator, the radiator hoses or other components of the cooling system.
- In the event of scalding, rinse the area affected immediately with lukewarm water.



Warning

Danger of poisoning Coolant is harmful to health.

- Keep coolant out of the reach of children.
- Do not allow coolant to come into contact with the skin, the eyes and clothing.
- Consult a doctor immediately if coolant is swallowed.
- Rinse the affected area immediately with plenty of water in the event of contact with the skin.
- Rinse eyes thoroughly with water and consult a doctor immediately if coolant gets into the eyes.
- Change clothing if coolant spills onto your clothing.



Condition

The engine is cold.

The radiator is completely full.

Preparatory work

- Stand motorcycle upright on a horizontal surface.

Main work

- Check coolant level in the compensating tank.

The coolant level must be between **MIN** and **MAX**.

- » If the coolant level in the compensating tank is not at the required level, but the tank is not empty:
 - Remove cap of the compensating tank.
 - Replenish coolant up to a level between **MIN** and **MAX**.

Coolant (📖 p. 136)

- Mount cap of the compensating tank.
- » If there is no coolant in the compensating tank:
 - Check the cooling system for leaks. 🛠️



Info

Do not start the motorcycle!

- Fill/bleed the cooling system. 🛠️ (📖 p. 109)

17.4 Draining the coolant 🛠️



Warning

Danger of scalding During motorcycle operation, the coolant gets very hot and is under pressure.

- Do not open the radiator, the radiator hoses or other cooling system components if the engine or the cooling system are at operating temperature.
- Allow the cooling system and the engine to cool down before you open the radiator, the radiator hoses or other components of the cooling system.
- In the event of scalding, rinse the area affected immediately with lukewarm water.



Warning

Danger of poisoning Coolant is harmful to health.

- Keep coolant out of the reach of children.
- Do not allow coolant to come into contact with the skin, the eyes and clothing.
- Consult a doctor immediately if coolant is swallowed.
- Rinse the affected area immediately with plenty of water in the event of contact with the skin.
- Rinse eyes thoroughly with water and consult a doctor immediately if coolant gets into the eyes.
- Change clothing if coolant spills onto your clothing.

Condition

The engine is cold.

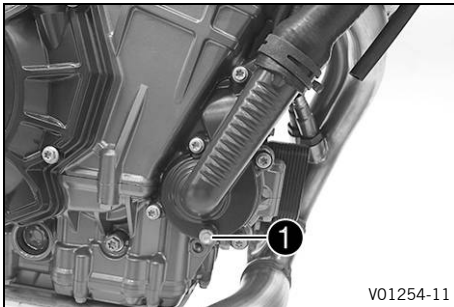

- Position the motorcycle upright.
- Position an appropriate container under the engine.
- Remove screw ① with the seal ring.
- Remove the radiator cap.
- Completely drain the coolant.
- Mount and tighten screw ① with a new seal ring.

Guideline

Screw plug, water pump drain hole	EJOTALtracs® Plus 60x14	8 Nm (5.9 lbf ft) Loctite®243™
-----------------------------------	--------------------------------	--

- Mount the radiator cap.



17.5 Filling/bleeding the cooling system ↘



Warning

Danger of poisoning Coolant is harmful to health.

- Keep coolant out of the reach of children.
- Do not allow coolant to come into contact with the skin, the eyes and clothing.
- Consult a doctor immediately if coolant is swallowed.
- Rinse the affected area immediately with plenty of water in the event of contact with the skin.
- Rinse eyes thoroughly with water and consult a doctor immediately if coolant gets into the eyes.
- Change clothing if coolant spills onto your clothing.

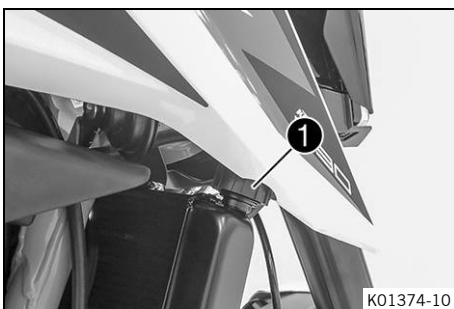

- Remove radiator cap ①.



- Remove bleeder screw ②.
- Tilt the vehicle slightly to the right.
- Pour in coolant until it emerges without bubbles at the vent hole, and then mount and tighten bleeder screw ② immediately.

Coolant	1.6 l (1.7 qt.)	Coolant (📖 p. 136)
---------	-----------------	--------------------

- Completely fill the radiator with coolant. Mount radiator cap ①.
- Rest the vehicle on the side stand.
- Check coolant level in the compensating tank. (📖 p. 107)

⚠ Danger
Danger of poisoning Exhaust gases are toxic and inhaling them may result in unconsciousness and death.

- Always make sure there is sufficient ventilation when running the engine.
- Use effective exhaust extraction when starting or running the engine in an enclosed space.

- Start the engine and run it until the 5th bar of the temperature indicator lights up.
- Stop the engine and allow it to cool down.
- When the engine is cool, check the coolant level in the radiator and, if necessary, add coolant.
- Check coolant level in the compensating tank. (📖 p. 107)

17.6 Changing the coolant

⚠ Warning
Danger of scalding During motorcycle operation, the coolant gets very hot and is under pressure.

- Do not open the radiator, the radiator hoses or other cooling system components if the engine or the cooling system are at operating temperature.
- Allow the cooling system and the engine to cool down before you open the radiator, the radiator hoses or other components of the cooling system.
- In the event of scalding, rinse the area affected immediately with lukewarm water.

⚠ Warning
Danger of poisoning Coolant is harmful to health.

- Keep coolant out of the reach of children.
- Do not allow coolant to come into contact with the skin, the eyes and clothing.
- Consult a doctor immediately if coolant is swallowed.
- Rinse the affected area immediately with plenty of water in the event of contact with the skin.
- Rinse eyes thoroughly with water and consult a doctor immediately if coolant gets into the eyes.
- Change clothing if coolant spills onto your clothing.

Condition
 The engine is cold.

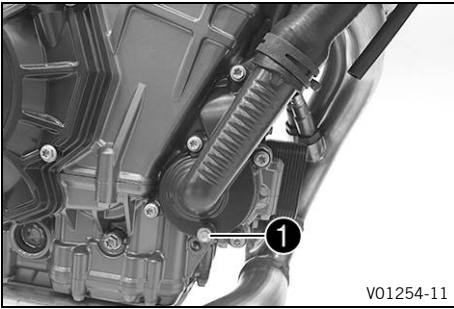

- Position the motorcycle upright.
- Position an appropriate container under the engine.
- Remove screw 1 with the seal ring.

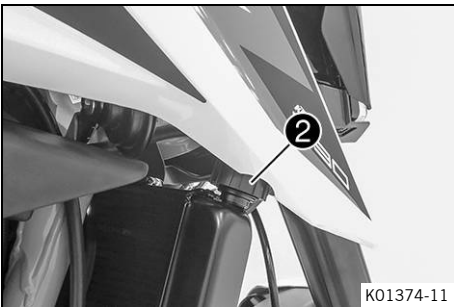

- Remove radiator cap 2.
- Completely drain the coolant.
- Mount and tighten screw 1 with a new seal ring.

Guideline

Screw plug, water pump drain hole	EJOTALtracs® Plus 60x14	8 Nm (5.9 lbf ft) Loctite®243™
-----------------------------------	--------------------------------	--

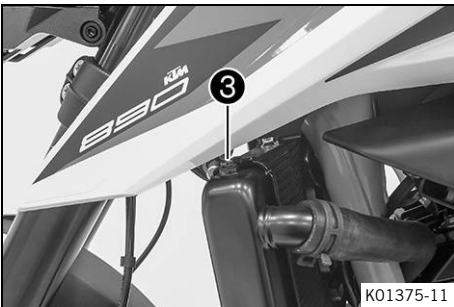

- Remove bleeder screw 3.
- Tilt the vehicle slightly to the right.
- Pour in coolant until it emerges without bubbles at the vent hole, and then mount and tighten bleeder screw 3 immediately.

Coolant	1.6 l (1.7 qt.)	Coolant (📖 p. 136)
---------	-----------------	--------------------

- Completely fill the radiator with coolant. Mount radiator cap 2.
- Rest the vehicle on the side stand.



Danger

Danger of poisoning Exhaust gases are toxic and inhaling them may result in unconsciousness and death.

- Always make sure there is sufficient ventilation when running the engine.
- Use effective exhaust extraction when starting or running the engine in an enclosed space.

- Start the engine and run it until the 5th bar of the temperature indicator lights up.
- Stop the engine and allow it to cool down.
- After the engine has cooled down, check the coolant level in the radiator and in the compensating tank again and add more coolant if necessary.



18.1 Ride Mode

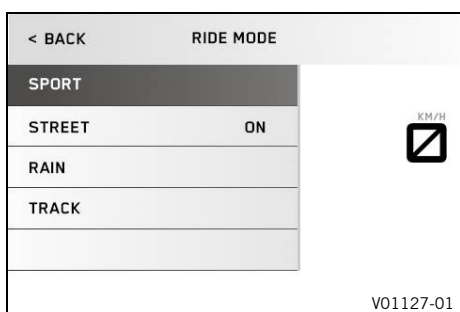

Possible states

- **SPORT** – Homologated performance with very direct response; the motorcycle traction control allows greater slip on the rear wheel.
- **STREET** – Homologated performance with balanced response; the motorcycle traction control allows normal slip on the rear wheel.
- **RAIN** – Homologated performance with soft response for improved rideability; the motorcycle traction control allows less slip on the rear wheel.
- **TRACK (optional)** – Setting with homologated performance and extremely direct response. The motorcycle traction control and the characteristic map of the throttle response can be individually set.

Various vehicle tunings can be selected in the **Ride Mode** menu. **SPORT**, **STREET**, **RAIN** and **TRACK** are available (optional). The riding mode selected last appears in the display. The drive mode can also be changed while riding with a closed throttle grip.

i Info

The riding mode selection does not influence the ABS.

18.2 Motorcycle traction control (MTC)

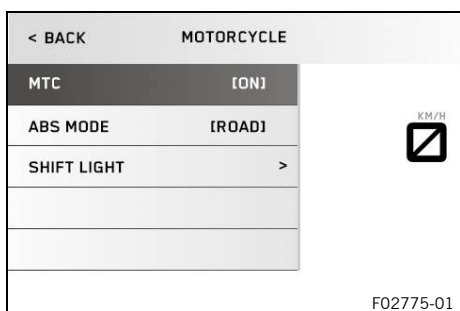

The motorcycle traction control (MTC) lowers the engine torque in case of loss of traction in the rear wheel.

i Info

When motorcycle traction control is switched off, the rear wheel may spin during strong acceleration and on surfaces with low grip, resulting in a risk of falling. After the ignition is switched on, motorcycle traction control is enabled again.

The motorcycle traction control is controlled via the **Ride Mode** (📖 p. 112) menu on the combination instrument. The motorcycle traction control can be switched off in the **Motorcycle** menu.

i Info

When the motorcycle traction control is active, the TC indicator lamp 📖 flashes. When motorcycle traction control is switched off, the TC indicator lamp 📖 lights up.

18.3 Slip adjustment (optional)

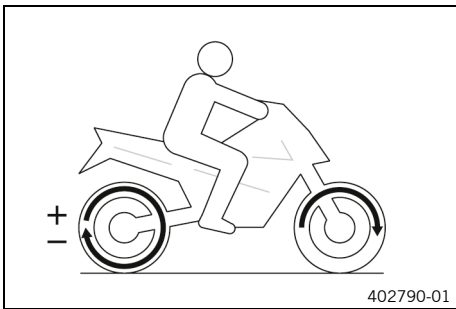

The spin adjuster is a motorcycle traction control function. The slip adjustment allows the motorcycle traction control to be tuned through nine levels to the desired characteristic map. Level 1 allows the maximum slip on the rear wheel, and level 9 the minimum.

The slip adjustment can be set while riding with a closed menu using the **UP** or **DOWN** button.

i Info

The slip adjustment is only available in **TRACK** riding mode (optional).

18.4 Throttle response (optional)

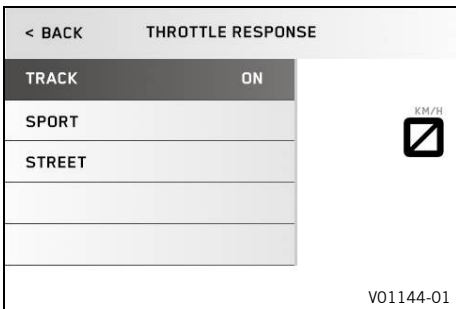

Possible states

- TRACK – Extremely direct response
- SPORT – Very direct response.
- STREET – Balanced response

The characteristic map of the throttle response can be adjusted in the **Throttle response** menu.

The **Throttle response** can also be set while riding with a closed throttle grip.

i Info

Throttle response is only available in drive mode **TRACK** (optional).

19.1 Checking the engine oil level

i Info

The engine oil level must be checked at normal engine operating temperature.

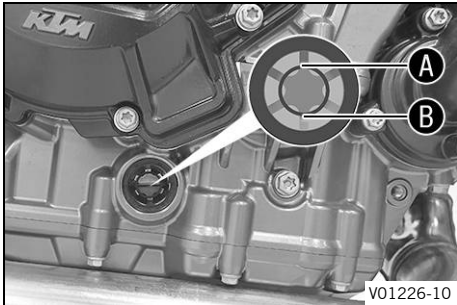

- Stand the motorcycle upright on a horizontal surface.
- Check the engine oil level.

i Info

After switching off the engine, wait one minute before checking the level.

The engine oil must be between marking **A** and marking **B** of the oil level viewer.

- » If the engine oil level is below the marking **B**:
 - Add engine oil. (📖 p. 116)
- » If the engine oil level is above the marking **A**:
 - Correct engine oil level.

19.2 Changing the engine oil and oil filter, cleaning the oil screens



Warning

Danger of scalding Engine and gear oil get very hot when the motorcycle is ridden.

- Wear suitable protective clothing and safety gloves.
- In the event of scalding, rinse the area affected immediately with lukewarm water.



Note

Environmental hazard Hazardous substances cause environmental damage.

- Dispose of oils, grease, filters, fuel, cleaning agents, brake fluid, etc., correctly and in compliance with the applicable regulations.

i Info

Drain the engine oil while the engine is at operating temperature.

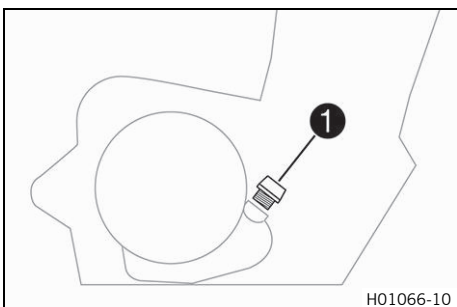

Main work

- Rest the motorcycle on its side stand on a horizontal surface.
- Position an appropriate container under the engine.
- Remove oil filler plug **1** with the O-ring from the clutch cover.

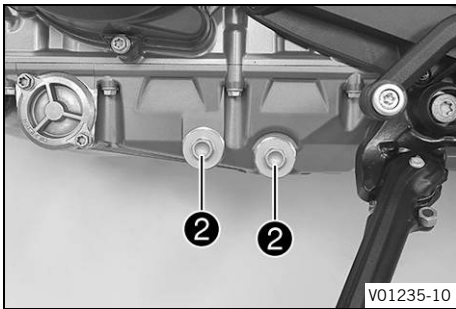

- Remove oil drain plugs **2** along with the magnets, the O-rings, and the oil screens.

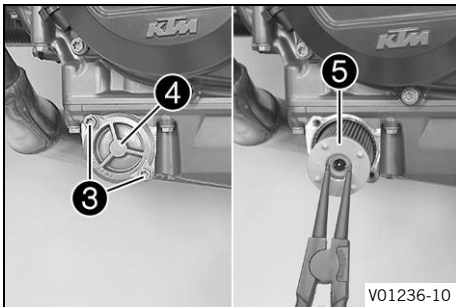

- Remove **3** screws. Take off oil filter cover **4** with the O-ring.
- Pull oil filter **5** out of the oil filter housing.

Lock ring plier (51012011000)

- Allow the engine oil to drain completely.
- Thoroughly clean the parts and the sealing surfaces.

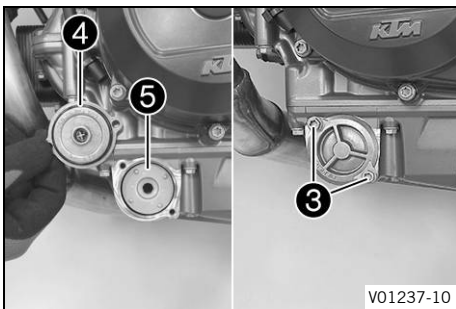

- Insert new oil filter **5**.

i Info	Only insert the oil filter by hand.
---------------	-------------------------------------

- Oil the O-ring of the oil filter cover. Position oil filter cover **4**.
- Mount and tighten screws **3**.

Guideline

Screw, oil filter cover	M5	6 Nm (4.4 lbf ft)
-------------------------	----	-------------------

- Thoroughly clean magnets **A** and oil screens **B** of the oil drain plugs.

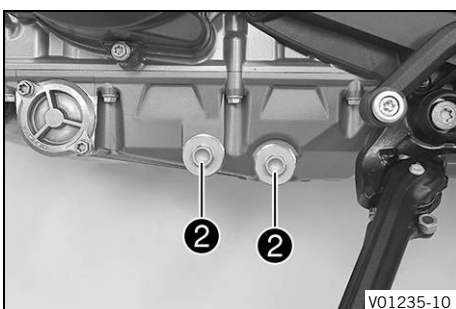
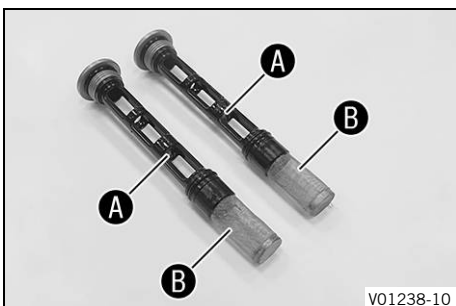

- Mount the oil drain plugs **2** with magnets and new seal rings, and tighten.

Guideline

Plug, oil screen	M20x1.5	20 Nm (14.8 lbf ft)
------------------	---------	---------------------

- Fill up with engine oil at the clutch cover.

Engine oil	2.9 l (3.1 qt.)	Engine oil (SAE 10W/50) (p. 136)
------------	-----------------	----------------------------------

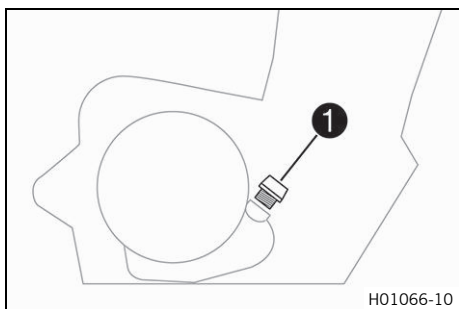

- Mount and tighten filler plug ① with the O-ring.



Danger

Danger of poisoning Exhaust gases are toxic and inhaling them may result in unconsciousness and death.

- Always make sure there is sufficient ventilation when running the engine.
- Use effective exhaust extraction when starting or running the engine in an enclosed space.

- Start the engine and check it for leaks.

Finishing work

- Check the engine oil level. (📖 p. 114)

19.3 Adding engine oil



Info

Too little engine oil or poor-quality engine oil will result in premature wear of the engine.

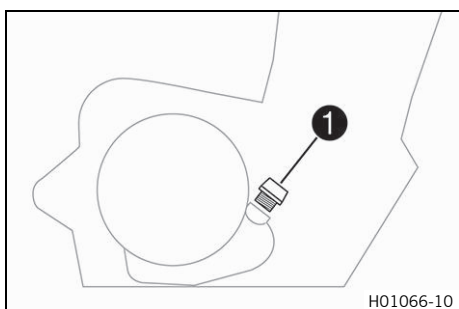

Main work

- Remove filler plug ① with the O-ring, and fill up with engine oil.
- Fill engine oil to the middle of the level viewer.

Engine oil (SAE 10W/50) (📖 p. 136)



Info

In order to achieve optimal engine oil performance, it is not advisable to mix different engine oils.

KTM recommends changing the engine oil where necessary.

- Mount and tighten filler plug ① with the O-ring.



Danger

Danger of poisoning Exhaust gases are toxic and inhaling them may result in unconsciousness and death.

- Always make sure there is sufficient ventilation when running the engine.
- Use effective exhaust extraction when starting or running the engine in an enclosed space.

- Start the engine and check for leaks.

Finishing work

- Check the engine oil level. (📖 p. 114)

19.4 Checking the free travel of the clutch lever

Note

Clutch damage If there is no free travel by the clutch lever, the clutch will begin to slip.

- Check the free travel of the clutch lever each time before using the motorcycle.
- Adjust the free travel of the clutch lever when necessary in accordance with the specification.



- Check the clutch lever for smooth operation.
- Move the handlebar to the straight-ahead position.
- Pull the clutch lever until resistance is perceptible, and determine the free travel **A**.

Free travel of clutch lever A	5 mm (0.2 in)
--------------------------------------	---------------

» If the free travel of the clutch lever does not meet specifications:

- Set the free travel of the clutch lever. ↗ (p. 117)

- Move the handlebar to and fro over the entire steering range.

The free travel of the clutch lever must not change.
--

- » If the free travel of the clutch lever changes:
 - Check the routing of the clutch cable.



19.5 Setting the free travel of the clutch lever ↗

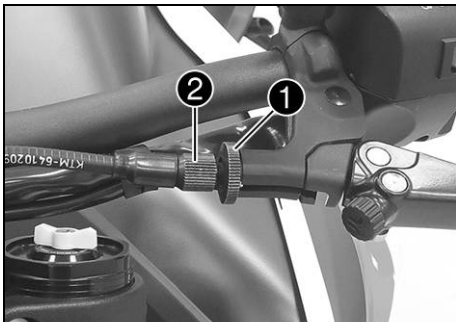

- Move the handlebar to the straight-ahead position.
- Loosen lock nut **1**.
- Adjust the free travel **A** by turning adjusting screw **2**.

Guideline

Free travel of clutch lever A	5 mm (0.2 in)
--------------------------------------	---------------

- Tighten lock nut **1**.

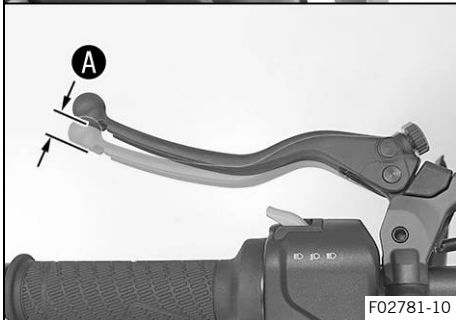

20.1 Cleaning the motorcycle

Note

Material damage Components become damaged or destroyed if a pressure cleaner is used incorrectly.

The high pressure forces water into the electrical components, connectors, throttle cables, and bearings, etc. Pressure which is too high causes malfunctions and destroys components.

- Do not direct the water jet directly on to electrical components, connectors, throttle cables or bearings.
- Maintain a minimum distance between the nozzle of the pressure cleaner and the component.

Minimum clearance 60 cm (23.6 in)



Note

Environmental hazard Hazardous substances cause environmental damage.

- Dispose of oils, grease, filters, fuel, cleaning agents, brake fluid, etc., correctly and in compliance with the applicable regulations.



Info

To maintain the value and appearance of the motorcycle over a long period, clean it regularly. Avoid direct sunshine when cleaning the motorcycle.

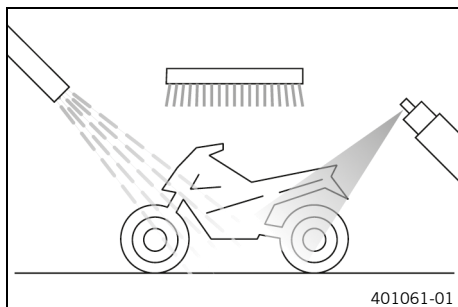

- Close off exhaust system to keep water from entering.
- Remove loose dirt first with a soft jet of water.
- Spray the heavily soiled parts with a normal commercial motorcycle cleaner and clean using a brush.

Motorcycle cleaner (🗉 p. 138)



Info

Use warm water containing normal motorcycle cleaner and a soft sponge. Never apply motorcycle cleaner to a dry vehicle; always rinse the vehicle with water first. If the vehicle was operated in road salt, clean it with cold water. Warm water would enhance the corrosive effects of salt.

- After rinsing the motorcycle with a gentle spray of water, allow it to dry thoroughly.
- Remove the closure of the exhaust system.



Warning

Danger of accidents Moisture and dirt impair the brake system.

- Brake carefully several times to dry out and remove dirt from the brake linings and the brake discs.

- After cleaning, ride the vehicle a short distance until the engine warms up.



Info

The heat produced causes water at inaccessible locations in the engine and on the brake system to evaporate.

- After the motorcycle has cooled down, lubricate all moving parts and pivot points.
- Clean the chain. (📖 p. 73)
- Treat bare metal (except for brake discs and the exhaust system) with a corrosion inhibitor.

Preserving materials for paints, metal and rubber (📖 p. 138)

- Treat all painted parts with a mild paint care product.

Perfect finish and high gloss polish for paints (📖 p. 138)

i Info
Do not polish parts that were matte when delivered as this would strongly impair the material quality.

- Treat all plastic parts and powder-coated parts with a mild cleaning and care product.

Special cleaner for glossy and matte paint finishes, metal and plastic surfaces (📖 p. 138)

- Lubricate the ignition/steering lock.

Universal oil spray (📖 p. 138)



20.2 Checks and maintenance steps for winter operation

i Info
If you use the motorcycle in winter, salt can be expected on the roads. You should therefore take precautions against aggressive road salt.
After riding on salted roads, thoroughly clean the vehicle with cold water and dry it well. Warm water enhances the corrosive effects of salt.

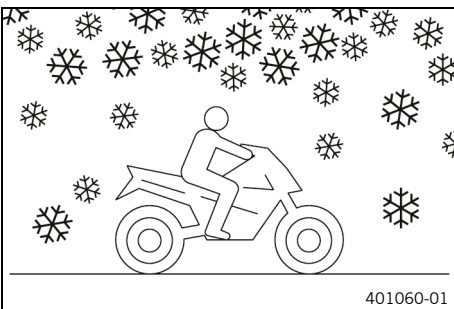

- Clean the motorcycle. (📖 p. 118)
- Clean the brake system.

i Info
After **EVERY** trip on salted roads, thoroughly clean the brake calipers and brake linings, after they have cooled down and without removing them, with cold water and dry them carefully.
After riding on salted roads, thoroughly clean the motorcycle with cold water and dry it well.

- Treat the engine, the swingarm, and all other bare or zinc-plated parts (except the brake discs) with a wax-based corrosion inhibitor.

i Info
Corrosion inhibitor must not come in contact with the brake discs as this would greatly reduce the braking force.

- Clean the chain. (📖 p. 73)



21.1 Storage

i Info

If you plan to garage the motorcycle for a longer period, perform the following steps or have them performed.

Before storing the motorcycle, check all parts for function and wear. If service, repairs, or replacements are necessary, you should do this during the storage period (less workshop overload). In this way, you can avoid long workshop waiting times at the start of the new season.

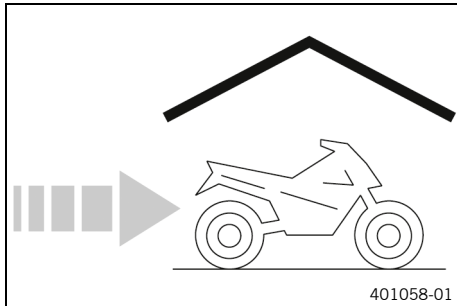

- When refueling for the last time before taking the motorcycle out of service, add fuel additive.

Fuel additive (📖 p. 138)

- Refuel. (📖 p. 60)

i Tip

Fill the fuel tank completely as specified, using fuel with the lowest possible ethanol content.

- Clean the motorcycle. (📖 p. 118)
- Change the engine oil and the oil filter, clean the oil screens. 🛠️ (📖 p. 114)
- Check the antifreeze and coolant level. (📖 p. 106)
- Check tire pressure. (📖 p. 92)
- Remove the 12-V battery. 🛠️ (📖 p. 94)
- Charge the 12-V battery. 🛠️ (📖 p. 96)

Guideline

Storage temperature of the 12-V battery without direct sunlight	0 ... 35 °C (32 ... 95 °F)
---	----------------------------

- Store the vehicle in a dry location that is not subject to large fluctuations in temperature.

i Info

KTM recommends jacking up the motorcycle.

- Raise the motorcycle with the rear lifting gear. (📖 p. 68)
- Lift the motorcycle with the front lifting gear. (📖 p. 68)
- Cover the motorcycle with a tarp or cover that is permeable to air.

i Info

Do not use non-porous materials since they prevent humidity from escaping, thus causing corrosion. Avoid running the engine for a short time only. Since the engine cannot warm up properly, the water vapor produced during combustion condenses and causes valves and the exhaust system to rust.

21.2 Preparing for use after storage

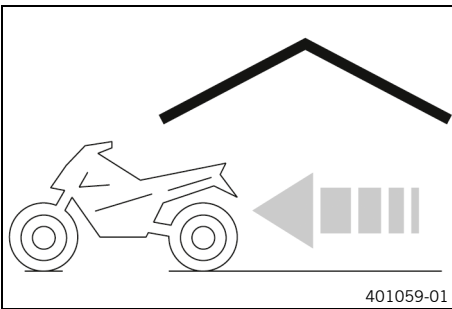

- Take the motorcycle off the front lifting gear. (📖 p. 69)
- Remove the rear of the motorcycle from the lifting gear. (📖 p. 68)
- Charge the 12-V battery. 🛡️ (📖 p. 96)
- Install the 12-V battery. 🛡️ (📖 p. 95)
- Set the time and date.
- Perform checks and maintenance measures when preparing for use. (📖 p. 51)
- Take a test ride.



Faults	Possible cause	Action
The engine does not turn when the start button is pressed	Operating error	– Carry out start procedure. (📖 p. 51)
	12 V battery discharged	– Charge the 12-V battery. 🛠️ (📖 p. 96) – Check the open-circuit current. 🛠️
	Fuse 1, 2 or 3 blown	– Change the fuses of individual electrical power consumers. (📖 p. 100)
	Main fuse burned out	– Change the main fuse. (📖 p. 98)
	No ground connection present	– Check the ground connection.
Engine turns only if the clutch lever is drawn	The vehicle is in gear	– Shift the transmission to neutral position.
	The vehicle is in gear and the side stand is folded out	– Shift the transmission to neutral position.
Engine turns but does not start	Operating error	– Carry out start procedure. (📖 p. 51)
	Fuse 3 blown	– Change the fuses of individual electrical power consumers. (📖 p. 100)
	Quick release coupling not joined	– Join quick release coupling.
	Malfunction in the electronic fuel injection	– Read out the fault memory using the KTM diagnostics tool. 🛠️
	Throttle opened while starting	– When starting, DO NOT open the throttle. – Carry out start procedure. (📖 p. 51)
Engine has too little power	Air filter is very dirty	– Remove the air filter. 🛠️ – Install the air filter. 🛠️
	Fuel filter is very dirty	– Check the fuel pressure. 🛠️
	Malfunction in the electronic fuel injection	– Read out the fault memory using the KTM diagnostics tool. 🛠️
Engine overheats	Too little coolant in cooling system	– Check the cooling system for leakage. – Check coolant level in the compensating tank. (📖 p. 107)
	Radiator fins very dirty	– Clean radiator fins.
	Foam formation in cooling system	– Drain the coolant. 🛠️ (📖 p. 108) – Fill/bleed the cooling system. 🛠️ (📖 p. 109)
	Buckled or damaged radiator hose	– Change the radiator hose. 🛠️
	Thermostat is faulty	– Check the thermostat. 🛠️
	Fuse 4 blown	– Change the fuses of individual electrical power consumers. (📖 p. 100)
	Defect in radiator fan system	– Check the radiator fan system. 🛠️
Malfunction indicator lamp lights up or flashes	Malfunction in the electronic fuel injection	– Read out the fault memory using the KTM diagnostics tool. 🛠️
N The idling speed indicator lamp does not light up when the transmission is in neutral	Gear position sensor not programmed	– Read out the fault memory using the KTM diagnostics tool. 🛠️
Engine dies during the trip	Lack of fuel	– Refuel. (📖 p. 60)
	Fuse 1, 2 or 3 blown	– Change the fuses of individual electrical power consumers. (📖 p. 100)
The ABS warning lamp lights up	ABS fuse blown	– Change the ABS fuses. (📖 p. 99)

Faults	Possible cause	Action
The ABS warning lamp lights up	Large difference in wheel speeds of the front and rear wheels	– Stop the vehicle, switch off the ignition, and start it again.
	Malfunction in ABS	– Read out the fault memory using the KTM diagnostics tool. 🛠️
High oil consumption	Engine vent hose bent	– Route the vent hose without bends or change it if necessary.
	Engine oil level too high	– Check the engine oil level. (📖 p. 114)
	Engine oil too thin (low viscosity)	– Change the engine oil and the oil filter, clean the oil screens. 🛠️ (📖 p. 114)
Headlight and position light are not functioning	Fuse 6 blown	– Change the fuses of individual electrical power consumers. (📖 p. 100)
Turn signal, brake light, and horn are not functional	Fuse 5 blown	– Change the fuses of individual electrical power consumers. (📖 p. 100)
Time is not (correctly) displayed	Fuse 1 is blown	– Change the fuses of individual electrical power consumers. (📖 p. 100) – Set the time and date.
12 V battery discharged	Ignition not switched off when vehicle was parked	– Charge the 12-V battery. 🛠️ (📖 p. 96)
	The 12-V battery is not being charged by the alternator	– Check the charging voltage. 🛠️ – Check the open-circuit current. 🛠️
Combination instrument shows nothing on the display	Fuse 1 or 2 blown	– Change the fuses of individual electrical power consumers. (📖 p. 100) – Set the time and date.

23.1 Engine

Design	2-cylinder 4-stroke in-line engine, water-cooled
Displacement	890 cm ³ (54.31 cu in)
Stroke	68.8 mm (2.709 in)
Bore	90.7 mm (3.571 in)
Compression ratio	13.5:1
Control	DOHC, 4 valves per cylinder controlled via cam lever, chain drive
Valve diameter, intake	37 mm (1.46 in)
Valve diameter, exhaust	30 mm (1.18 in)
Valve play, cold	
Intake at: 20 °C (68 °F)	0.10 ... 0.15 mm (0.0039 ... 0.0059 in)
Exhaust at: 20 °C (68 °F)	0.15 ... 0.20 mm (0.0059 ... 0.0079 in)
Crankshaft bearing	Slide bearing
Conrod bearing	Slide bearing
Piston pin bearing	Steel pin in bronze bush
Pistons	Forged light alloy
Piston rings	1 compression ring, 1 lower compression ring, 1 oil ring with spring expander
Engine lubrication	Pressure circulation lubrication with 2 trochoidal pumps
Primary transmission	39:75
Clutch	Slipper clutch in oil bath/mechanically operated
Transmission	6-gear transmission, claw shifted
Transmission ratio	
First gear	13:37
Second gear	17:34
Third gear	20:31
Fourth gear	22:28
Fifth gear	24:26
Sixth gear	23:22
Mixture preparation	Electronic fuel injection
Ignition	Contactless controlled fully electronic ignition with digital ignition adjustment
Alternator	12 V, 400 W
Spark plug	NGK LMAR9AI-10
Spark plug electrode gap	1.0 mm (0.039 in)
Cooling	Water cooling, permanent circulation of coolant by water pump
Idle speed	1,600 ± 50 rpm
Starting aid	Starter motor

23.2 Engine tightening torques

Screw plug, water pump drain hole	EJOTALtracs®Plus 60x14	8 Nm (5.9 lbf ft)	Loctite®243™
Screw, bleeder flange	EJOTALtracs® M6x12	8 Nm (5.9 lbf ft)	Loctite®243™
Hose clamp, intake flange	M4	2.5 Nm (1.84 lbf ft)	
Nozzle, engine vent	M5	2 Nm (1.5 lbf ft)	
Oil nozzle for piston cooling	M5	2 Nm (1.5 lbf ft)	
Oil nozzle in cylinder head	M5	2 Nm (1.5 lbf ft)	
Remaining screws, engine	M5	6 Nm (4.4 lbf ft)	
Screw, cam lever axial lock	M5	6 Nm (4.4 lbf ft)	Loctite®243™
Screw, crankshaft speed sensor	M5	6 Nm (4.4 lbf ft)	Loctite®243™
Screw, gear position sensor	M5	5 Nm (3.7 lbf ft)	Loctite®243™
Screw, oil filter cover	M5	6 Nm (4.4 lbf ft)	
Screw, pressure plate	M5	3 Nm (2.2 lbf ft)	Loctite®243™
Screw, shift drum retaining bracket	M5	6 Nm (4.4 lbf ft)	Loctite®243™
Screw, shift shaft sensor	M5	6 Nm (4.4 lbf ft)	Loctite®243™
Screw, thermostat case	M5	6 Nm (4.4 lbf ft)	Loctite®243™
Securing screw, balancer shaft	M5	5 Nm (3.7 lbf ft)	Loctite®243™
Swing angle sensor screw	M5	6 Nm (4.4 lbf ft)	Loctite®243™
Nut, starter motor cable	M6	5 Nm (3.7 lbf ft)	
Remaining screws, engine	M6	10 Nm (7.4 lbf ft)	
Screw, alternator cover	M6x30	10 Nm (7.4 lbf ft)	
Screw, alternator cover	M6x35	10 Nm (7.4 lbf ft)	
Screw, camshaft bearing bridge	M6	10 Nm (7.4 lbf ft)	
Screw, clutch cable retaining bracket	M6	10 Nm (7.4 lbf ft)	Loctite®243™
Screw, clutch cover	M6	10 Nm (7.4 lbf ft)	
Screw, clutch release lever	M6	10 Nm (7.4 lbf ft)	Loctite®243™
Screw, clutch spring	M6	8 Nm (5.9 lbf ft)	
Screw, cylinder head	M6	10 Nm (7.4 lbf ft)	
Screw, engine case	M6x30	12 Nm (8.9 lbf ft)	
Screw, engine case	M6x60	12 Nm (8.9 lbf ft)	
Screw, freewheel ring	M6	14 Nm (10.3 lbf ft)	Loctite®243™
Screw, ignition coil	M6	8 Nm (5.9 lbf ft)	

23 TECHNICAL SPECIFICATIONS

Screw, locking lever	M6	10 Nm (7.4 lbf ft) Loctite®243™
Screw, main shaft bearing support	M6	10 Nm (7.4 lbf ft) Loctite®243™
Screw, oil pan	M6x30	10 Nm (7.4 lbf ft)
Screw, oil pan	M6x35	10 Nm (7.4 lbf ft)
Screw, oil pump cover	M6	10 Nm (7.4 lbf ft) Loctite®243™
Screw, oil pump unit	M6	10 Nm (7.4 lbf ft)
Screw, oil/water heat exchanger	M6	10 Nm (7.4 lbf ft) Loctite®243™
Screw, shift drum locating	M6	10 Nm (7.4 lbf ft) Loctite®243™
Screw, shift lever	M6	14 Nm (10.3 lbf ft) Loctite®243™
Screw, shift shaft retaining bracket	M6	10 Nm (7.4 lbf ft) Loctite®243™
Screw, starter motor	M6	10 Nm (7.4 lbf ft)
Screw, stator	M6	10 Nm (7.4 lbf ft) Loctite®243™
Screw, timing chain shaft	M6	10 Nm (7.4 lbf ft)
Screw, upper guide rail	M6	8 Nm (5.9 lbf ft) Loctite®243™
Screw, valve cover	M6	10 Nm (7.4 lbf ft)
Screw, water pump cover	M6	10 Nm (7.4 lbf ft) Loctite®243™
Screw, water pump wheel	M6	10 Nm (7.4 lbf ft) Loctite®243™
Nut, exhaust flange	M8	15 Nm (11.1 lbf ft) Copper paste
Oil nozzle for clutch lubrication	M8	5 Nm (3.7 lbf ft) Loctite®243™
Remaining screws for engine	M8	20 Nm (14.8 lbf ft)
Screw plug, locking screw	M8	15 Nm (11.1 lbf ft)
Screw, engine case	M8x45	25 Nm (18.4 lbf ft) Screw support greased
Screw, engine case	M8x55	25 Nm (18.4 lbf ft) Screw support greased
Screw, engine case	M8x65	25 Nm (18.4 lbf ft) Screw support greased
Screw, engine case	M8x90	25 Nm (18.4 lbf ft) Screw support greased
Screw, knock sensor	M8	20 Nm (14.8 lbf ft)
Screw, oil pump idler gear	M8	15 Nm (11.1 lbf ft) Loctite®243™
Screw, tensioning rail	M8	15 Nm (11.1 lbf ft) Loctite®243™
Stud, exhaust flange	M8	15 Nm (11.1 lbf ft) Loctite®243™

Screw, conrod bearing	M8x0.75	1st stage 5 Nm (3.7 lbf ft) 2nd stage 20 Nm (14.8 lbf ft) 3rd stage 90° Screw support and thread oiled
Spark plug	M10	11 Nm (8.1 lbf ft)
Oil pressure sensor	M10x1	10 Nm (7.4 lbf ft)
Screw plug, bearing support	M10x1	12 Nm (8.9 lbf ft) Loctite®243™
Screw plug, cam lever axis	M10x1	8 Nm (5.9 lbf ft)
Screw, unlocking of timing chain tensioner	M10x1	8 Nm (5.9 lbf ft)
Coolant temperature sensor	M10x1.25	10 Nm (7.4 lbf ft)
Screw, cylinder head	M10x1.25	Tightening sequence: Observe tightening sequence. 1st stage 5 Nm (3.7 lbf ft) 2nd stage 15 Nm (11.1 lbf ft) 3rd stage 90° 4th stage 90° Screw support greased/thread oiled
Screw plug, cylinder head oil drain	M12x1.5	15 Nm (11.1 lbf ft)
Screw, rotor	M12x1.5	90 Nm (66.4 lbf ft) Thread greased
Screw plug, water jacket	M16x1.5	20 Nm (14.8 lbf ft) Loctite®243™
Nut, engine sprocket	M20x1.5	120 Nm (88.5 lbf ft) Loctite®243™
Nut, inner clutch hub	M20x1.5	135 Nm (99.6 lbf ft)
Plug, oil screen	M20x1.5	20 Nm (14.8 lbf ft)
Plug, timing chain tensioner	M24x1.5	25 Nm (18.4 lbf ft)
Screw plug, alternator cover	M24x1.5	8 Nm (5.9 lbf ft)

23.3 Capacities

23.3.1 Engine oil

Engine oil	2.9 l (3.1 qt.)	Engine oil (SAE 10W/50) ( p. 136)
------------	-----------------	--

23.3.2 Coolant

Coolant	1.6 l (1.7 qt.)	Coolant ( p. 136)
---------	-----------------	---

23.3.3 Fuel

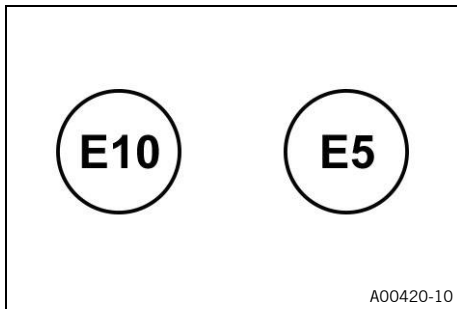

Please observe the labels on EU fuel pumps.

Fuel tank capacity, approx.	14 l (3.7 US gal)	Super unleaded (ROZ 95) ( p. 137)
-----------------------------	-------------------	--

23.4 Chassis

Frame	Lattice frame made of chrome molybdenum steel tubing, powder-coated
Fork	WP APEX 3343
Shock absorber	WP APEX 5746
Brake system	
front	Double disc brake with radially mounted four-piston brake calipers, floating brake discs
rear	Disc brake with single-piston brake caliper, floating
Brake discs - diameter	
front	320 mm (12.6 in)
rear	240 mm (9.45 in)
Brake discs - wear limit	
front	4.2 mm (0.165 in)
rear	4.5 mm (0.177 in)
Tire pressure when solo	
front	2.3 bar (33 psi)
rear	2.5 bar (36 psi)
Tire pressure with passenger / full payload	
front	2.3 bar (33 psi)
rear	2.6 bar (38 psi)
Secondary drive ratio	16:41
Chain	5/8 x 1/4" (520) X-ring
Steering head angle	65.7°
Wheelbase	1,482 ± 15 mm (58.35 ± 0.59 in)
Seat height unloaded	834 mm (32.83 in)
Ground clearance unloaded	206 mm (8.11 in)
Roadworthy weight	186.4 kg (410.9 lb.)
Maximum permissible front axle load	160 kg (353 lb.)
Maximum permissible rear axle load	270 kg (595 lb.)
Maximum permissible overall weight	430 kg (948 lb.)

23.5 Electrical system

12 V battery	HTZ12A-BS	Battery voltage: 12 V Nominal capacity: 10 Ah Maintenance-free
Fuse	75011088010	10 A
Fuse	75011088015	15 A
Fuse	75011088025	25 A
Fuse	58011109130	30 A

Low beam/high beam	LED
Daytime running light/position light	LED
Combination instrument lighting and indicator lamps	LED
Turn signal	LED
Brake/tail light	LED
License plate lamp	LED

23.6 Tires

Front tire	Rear tire
120/70 ZR 17 M/C (58W) TL Michelin Power Cup 2	180/55 ZR 17 M/C (73W) TL Michelin Power Cup 2
The tires specified represent one of the possible series production tires. For alternative manufacturers, if any, contact an authorized dealer or qualified tire dealership. If local road approval regulations apply, these and the respective technical specifications must be observed. Additional information is available in the Service section under: KTM.COM	

23.7 Fork

Fork article number	05.58.8T.49
Fork	WP APEX 3343
Compression damping	
Comfort	20 clicks
Standard	15 clicks
Sport	4 clicks
Full payload	15 clicks
Rebound damping	
Comfort	20 clicks
Standard	15 clicks
Sport	10 clicks
Full payload	15 clicks
Spring rate	
Soft	6.5 N/mm (37.1 lb/in)
Medium (standard)	7.5 N/mm (42.8 lb/in)
Hard	8.5 N/mm (48.5 lb/in)
Spring length with preload spacer(s)	417.5 mm (16.437 in)
Fork length	781 mm (30.75 in)

Fork oil per fork leg	495 ± 5 ml (16.74 ± 0.17 fl. oz.)	Fork oil (SAE 4) (48601166S1) ( p. 137)
-----------------------	-----------------------------------	--

23.8 Shock absorber

Shock absorber article number	15.18.7T.49	
Shock absorber	WP APEX 5746	
Low-speed compression damping		
Comfort	16 clicks	
Standard	14 clicks	
Sport	10 clicks	
Full payload	14 clicks	
High-speed compression damping		
Comfort	1.5 turns	
Standard	1.5 turns	
Sport	1.5 turns	
Full payload	1.5 turns	
Rebound damping		
Comfort	17 clicks	
Standard	14 clicks	
Sport	12 clicks	
Full payload	11 clicks	
Spring preload - Preload Adjuster		
Comfort	1 turn	
Standard	3 turns	
Sport	5.5 turns	
Full payload	6 turns	
Spring rate		
Soft	138 N/mm (788 lb/in)	
Medium (standard)	150 N/mm (857 lb/in)	
Hard	162 N/mm (925 lb/in)	
Spring length	195 mm (7.68 in)	
Gas pressure	10 bar (145 psi)	
Fitted length	392 mm (15.43 in)	
Damper oil		Shock absorber fluid (SAE 2.5) (50180751S1) ( p. 137)

23.9 Chassis tightening torques

Brake fluid reservoir cover, front	-	0.7 Nm (0.52 lbf ft)
Radiator hose hose clamp	-	2.2 Nm (1.62 lbf ft)
Remaining screws, chassis	EJOTPT® K45x12	1 Nm (0.7 lbf ft)
Remaining screws, chassis	EJOTPT® K50x12	1 Nm (0.7 lbf ft)
Remaining screws, chassis	EJOTPT® K50x14	1 Nm (0.7 lbf ft)
Remaining screws, chassis	EJOTPT® K50x16	2 Nm (1.5 lbf ft)
Remaining screws, chassis	EJOTPT® K50x18	2 Nm (1.5 lbf ft)
Screw, headlight	EJOT PT® K50x14	4 Nm (3 lbf ft)

Throttle valve body hose clamp	-	2.8 Nm (2.07 lbf ft)	
Remaining nuts, chassis	M4	3 Nm (2.2 lbf ft)	
Remaining screws, chassis	M4	3 Nm (2.2 lbf ft)	
Screw, fixed grip, left	M4	3 Nm (2.2 lbf ft)	
Remaining nuts, chassis	M5	5 Nm (3.7 lbf ft)	
Remaining screws, chassis	M5	5 Nm (3.7 lbf ft)	
Screw, air filter box	M5	3 Nm (2.2 lbf ft)	
Screw, brake fluid reservoir for rear brake	M5	5 Nm (3.7 lbf ft)	
Screw, combination instrument	M5	4 Nm (3 lbf ft)	
Screw, combination switch, left	M5	2 Nm (1.5 lbf ft)	
Screw, combination switch, right	M5	5 Nm (3.7 lbf ft)	
Screw, engine sprocket cover	M5	5 Nm (3.7 lbf ft)	Loctite®243™
Screw, fuel level sensor	M5	3 Nm (2.2 lbf ft)	
Screw, fuel tank cover	M5	3 Nm (2.2 lbf ft)	
Screw, headlight mask	M5	5 Nm (3.7 lbf ft)	Loctite®243™
Screw, heat guard	M5	5 Nm (3.7 lbf ft)	
Screw, license plate holder	M5	3 Nm (2.2 lbf ft)	
Screw, lower rear panel	M5	3 Nm (2.2 lbf ft)	
Screw, mask support	M5	3 Nm (2.2 lbf ft)	
Screw, side stand sensor	M5	2 Nm (1.5 lbf ft)	Loctite®243™
Screw, support roller	M5	4 Nm (3 lbf ft)	Loctite®243™
Screw, throttle grip	M5	3.5 Nm (2.58 lbf ft)	
Screw, trim	M5	3 Nm (2.2 lbf ft)	
Nut, cable on starter motor	M6	5 Nm (3.7 lbf ft)	
Nut, hand brake lever	M6	5 Nm (3.7 lbf ft)	
Nut, push rod, foot brake lever	M6	6 Nm (4.4 lbf ft)	
Nut, shift rod	M6	6 Nm (4.4 lbf ft)	
Nut, shift rod	M6LH	6 Nm (4.4 lbf ft)	
Remaining nuts, chassis	M6	10 Nm (7.4 lbf ft)	
Remaining screws, chassis	M6	10 Nm (7.4 lbf ft)	
Screw, activated carbon filter holder	M6	6 Nm (4.4 lbf ft)	
Screw, ball joint of push rod on foot brake cylinder	M6	10 Nm (7.4 lbf ft)	Loctite®243™
Screw, battery support bracket	M6	4.5 Nm (3.32 lbf ft)	
Screw, battery terminal	M6x12	4.5 Nm (3.32 lbf ft)	
Screw, battery terminal	M6x20	4.5 Nm (3.32 lbf ft)	
Screw, brake assembly	M6	5 Nm (3.7 lbf ft)	
Screw, clutch assembly	M6	5 Nm (3.7 lbf ft)	
Screw, foot brake cylinder	M6	10 Nm (7.4 lbf ft)	Loctite®243™

23 TECHNICAL SPECIFICATIONS

Screw, foot brake lever stub	M6	10 Nm (7.4 lbf ft) Loctite®243™
Screw, front rider's seat	M6	10 Nm (7.4 lbf ft) Loctite®243™
Screw, fuel tank rollers	M6	10 Nm (7.4 lbf ft) Loctite®243™
Screw, fuel tank spoiler	M6	3 Nm (2.2 lbf ft)
Screw, ground wire on frame	M6	6 Nm (4.4 lbf ft)
Screw, ground wire to starter motor	M6	10 Nm (7.4 lbf ft)
Screw, ignition lock (tamper-proof screw)	M6	Tighten until the head tears off. Loctite®243™
Screw, inertial measurement unit	M6	5 Nm (3.7 lbf ft)
Screw, license plate holder	M6	10 Nm (7.4 lbf ft) Loctite®243™
Screw, magnetic holder on side stand	M6	2 Nm (1.5 lbf ft) Loctite®243™
Screw, main silencer clamp	M6	8 Nm (5.9 lbf ft)
Screw, manifold clamp	M6	8 Nm (5.9 lbf ft)
Screw, radiator bracket, bottom	M6	5 Nm (3.7 lbf ft)
Screw, seat lock	M6	8 Nm (5.9 lbf ft) Loctite® 222™
Screw, shift lever stub	M6	10 Nm (7.4 lbf ft) Loctite®243™
Screw, shift rod	M6	10 Nm (7.4 lbf ft) Loctite®243™
Screw, shift shaft deflector on shift shaft	M6	10 Nm (7.4 lbf ft) Loctite®243™
Screw, wheel speed sensor	M6	6 Nm (4.4 lbf ft)
Nut, manifold on cylinder head	M8	Tighten the nuts evenly. Do not bend the metal. 13 Nm (9.6 lbf ft) Copper paste
Nut, rear sprocket screw	M8	35 Nm (25.8 lbf ft) Loctite®2701™
Pin, rear brake caliper	M8	14 Nm (10.3 lbf ft)
Remaining nuts, chassis	M8	25 Nm (18.4 lbf ft)
Remaining screws, chassis	M8	25 Nm (18.4 lbf ft)
Screw, bottom triple clamp	M8	12 Nm (8.9 lbf ft)
Screw, cross member	M8x18	25 Nm (18.4 lbf ft) Loctite®243™
Screw, cross member in rear	M8x35	25 Nm (18.4 lbf ft) Loctite®243™
Screw, engine fixing arm linkage bracket	M8	25 Nm (18.4 lbf ft) Loctite®243™
Screw, foot brake lever	M8	25 Nm (18.4 lbf ft) Loctite®2701™
Screw, footrest bracket, rear	M8x25	25 Nm (18.4 lbf ft) Loctite®243™

Screw, footrest bracket, rear	M8x40	25 Nm (18.4 lbf ft) Loctite®243™
Screw, fork stub	M8	15 Nm (11.1 lbf ft)
Screw, front brake disc	M8	28 Nm (20.7 lbf ft) Loctite®2701™
Screw, grab handle	M8x50	25 Nm (18.4 lbf ft) Loctite®243™
Screw, handlebar clamp	M8	20 Nm (14.8 lbf ft)
Screw, main silencer fastening	M8	15 Nm (11.1 lbf ft)
Screw, main silencer holder	M8x25	25 Nm (18.4 lbf ft) Loctite®243™
Screw, main silencer holder	M8x40	25 Nm (18.4 lbf ft) Loctite®243™
Screw, main silencer holder	M8x45	25 Nm (18.4 lbf ft) Loctite®243™
Screw, main silencer holder	M8x60	25 Nm (18.4 lbf ft) Loctite®243™
Screw, passenger seat bracket	M8	25 Nm (18.4 lbf ft) Loctite®243™
Screw, presilencer on frame	M8	15 Nm (11.1 lbf ft) Loctite®243™
Screw, rear brake disc	M8	28 Nm (20.7 lbf ft) Loctite®2701™
Screw, shift lever	M8	25 Nm (18.4 lbf ft) Loctite®2701™
Screw, spring holder plate on side stand bracket	M8	15 Nm (11.1 lbf ft) Loctite®2701™
Screw, steering damper on holder	M8	8 Nm (5.9 lbf ft) Loctite®243™
Screw, steering damper on triple clamp	M8	8 Nm (5.9 lbf ft) Loctite®243™
Screw, steering stem	M8	20 Nm (14.8 lbf ft) Loctite®243™
Screw, subframe brace	M8	25 Nm (18.4 lbf ft) Loctite®243™
Screw, top triple clamp	M8	15 Nm (11.1 lbf ft)
Engine carrying screw	M10	45 Nm (33.2 lbf ft) Loctite®243™
Remaining nuts, chassis	M10	45 Nm (33.2 lbf ft)
Remaining screws, chassis	M10	45 Nm (33.2 lbf ft)
Screw, front footrest bracket	M10x65	45 Nm (33.2 lbf ft) Loctite®243™
Screw, front footrest bracket	M10x80	45 Nm (33.2 lbf ft) Loctite®243™
Screw, handlebar support	M10	45 Nm (33.2 lbf ft) Loctite®243™
Screw, side stand	M10	35 Nm (25.8 lbf ft) Loctite®243™

23 TECHNICAL SPECIFICATIONS

Screw, side stand bracket	M10	45 Nm (33.2 lbf ft) Loctite®243™
Screw, subframe	M10	50 Nm (36.9 lbf ft) Loctite®243™
Banjo bolt, brake line	M10x1	25 Nm (18.4 lbf ft)
Screw, front brake caliper	M10x1.25	45 Nm (33.2 lbf ft) Loctite®243™
Screw, bottom shock absorber	M12	80 Nm (59 lbf ft) Loctite®2701™
Screw, swingarm pivot	M12	100 Nm (73.8 lbf ft)
Screw, top shock absorber	M12	80 Nm (59 lbf ft) Loctite®2701™
Lambda sensor	M18x1.5	50 Nm (36.9 lbf ft)
Adjusting screw, swingarm	M20LHx1.5	10 Nm (7.4 lbf ft)
Screw, steering head	M20x1.5	18 Nm (13.3 lbf ft)
Nut, rear wheel spindle	M25x1.5	90 Nm (66.4 lbf ft) Thread and contact area of wheel spindle greased
Screw, front wheel spindle	M25x1.5	45 Nm (33.2 lbf ft) Thread greased

24.1 Declarations of conformity

i Info

The functional and equipment scope is model-dependent and may not include all wireless systems and application areas referred to.

COBO SpA hereby declares that the **BT-ROUTER** wireless system conforms with the relevant guidelines. The full text of the Declaration of Conformity is available at the following Internet address.

Certification website: <http://www.ktm.com/btrouter>

KTM AG hereby declares that the **Immo641** wireless system conforms with the relevant guidelines. The full text of the Declaration of Conformity is available at the following Internet address.

Certification website: <http://www.ktm.com/immo641>

Schrader Electronics Ltd hereby declares that the **Tyre Pressure Monitoring System** wireless system conforms with the relevant guidelines. The full text of the Declaration of Conformity is available at the following Internet address.

Certification website: <http://www.ktm.com/tpms>

24.2 Country-specific declarations of conformity

Immo641



MCMC
CIDF18000141





CNC COMISIÓN NACIONAL
DE COMUNICACIONES
H-21170

Complies with
IMDA Standards
N2035-18

ictQATAR
Type Approval reg. No.:
CRA/SA/2018/R-7050

RTIKTM18-0315, KTM, Minda Immo641
La operación de este equipo está sujeta a las siguientes dos condiciones: (1) es posible que este equipo o dispositivo no cause interferencia perjudicial y (2) este equipo o dispositivo debe aceptar cualquier interferencia, incluyendo la que pueda causar su operación no deseada.



R-R-KTM-MindaImmo641

Company Name: KTM AG
Equipment Name: Immobilizer System
Model Name: Minda Immo641
Manufactured Date:
Manufacturer / Country: Minda Corporation Limited / India



UA.TR.109

Israel 51-65016

מוצר זה פטור מרישיון הפעלה אחרות.
המוצר אסור לשימוש למתן שירות לצד ג'.
אסור להחליף אנטנת המכשיר המקורית.
אסור לעשות במכשיר כל שינוי טכני.

This product does not need an Israeli wireless operation license.
It is forbidden to use this product for service to third party.
It is forbidden to replace the original antenna
It is forbidden to make any technical change in this product.

This product contains radio equipment (125 kHz transmitter) which is conform with the regulations for communications equipment (extremely low-power radio station) specified in article 6, paragraph 1 of the Radio Law Enforcement Regulations.

AGREE PAR L'ANRT MAROC
Numéro d'agrément: MIR 16565 ANRT 2018
Date d'agrément: 15/05/2018



ANATEL
Agência Nacional de Telecomunicações
03469-18-11400

Este equipamento opera em caráter secundário, isto é, não tem direito a proteção contra interferência prejudicial, mesmo de estações do mesmo tipo, e não pode causar interferência a sistemas operando em caráter primário.

F03629-01

Brake fluid DOT 4 / DOT 5.1

Standard/classification

- DOT

Guideline

- Use only brake fluid that complies with the specified standard (see specifications on the container) and that exhibits the corresponding properties.

Recommended supplier

Castrol

- REACT PERFORMANCE DOT 4

MOTOREX®

- Brake Fluid DOT 5.1

Coolant

Guideline

- Only use high-grade, silicate-free coolant with corrosion inhibitor additive for aluminum motors. Low grade and unsuitable antifreeze causes corrosion, deposits and frothing.
- Do not use pure water as only coolant is able to meet the requirements needed in terms of corrosion protection and lubrication properties.
- Only use coolant that complies with the requirements stated (see specifications on the container) and that has the relevant properties.

Antifreeze protection to at least	-25 °C (-13 °F)
-----------------------------------	-----------------

The mixture ratio must be adjusted to the necessary antifreeze protection. Use distilled water if the coolant needs to be diluted.

The use of premixed coolant is recommended.

Observe the coolant manufacturer specifications for antifreeze protection, dilution and miscibility (compatibility) with other coolants.

Recommended supplier

MOTOREX®

- COOLANT M3.0

Engine oil (SAE 10W/50)

Standard/classification

- JASO T903 MA2 (📖 p. 139)
- SAE (📖 p. 139) (SAE 10W/50)

Guideline

- Use only engine oils that comply with the specified standards (see specifications on the container) and that possess the corresponding properties.

Fully synthetic engine oil

Recommended supplier

MOTOREX®

- Power Synt 4T

Fork oil (SAE 4) (48601166S1)**Standard/classification**

- SAE (📖 p. 139) (SAE 4)

Guideline

- Use only oils that comply with the specified standards (see specifications on the container) and that exhibit the corresponding properties.

Shock absorber fluid (SAE 2.5) (50180751S1)**Standard/classification**

- SAE (📖 p. 139) (SAE 2.5)

Guideline

- Use only oils that comply with the specified standards (see specifications on the container) and that exhibit the corresponding properties.

Super unleaded (ROZ 95)**Standard/classification**

- DIN EN 228 (ROZ 95)

Guideline

- Only use super unleaded fuel that matches or is equivalent to the specified standard.
- Fuel with an ethanol content of up to 10% (E10 fuel) is safe to use.

**Info**

Do **not** use fuel containing methanol (e.g., M15, M85, M100) or more than 10% ethanol (e.g., E15, E25, E85, E100).

Chain cleaner

Recommended supplier

MOTOREX®

- Chain Clean

Fuel additive

Recommended supplier

MOTOREX®

- Fuel Stabilizer

Long-life grease

Recommended supplier

MOTOREX®

- Bike Grease 2000

Motorcycle cleaner

Recommended supplier

MOTOREX®

- Moto Clean

Perfect finish and high gloss polish for paints

Recommended supplier

MOTOREX®

- Moto Shine

Preserving materials for paints, metal and rubber

Recommended supplier

MOTOREX®

- Moto Protect

Special cleaner for glossy and matte paint finishes, metal and plastic surfaces

Recommended supplier

MOTOREX®

- Quick Cleaner

Street chain spray

Guideline

Recommended supplier

MOTOREX®

- Chainlube Road Strong

Universal oil spray

Recommended supplier

MOTOREX®

- Joker 440 Synthetic

JASO T903 MA2

Different technical development directions required a separate specification for motorcycles – the **JASO T903 MA2** standard.

Earlier, engine oils from the automobile industry were used for motorcycles because there was no separate motorcycle specification.

Whereas long service intervals are demanded for automobile engines, the focus for motorcycle engines is on high performance at high engine speeds.

In most motorcycle engines, the transmission and clutch are lubricated with the same oil.

The **JASO T903 MA2** standard meets these special requirements.

SAE



The SAE viscosity classes were defined by the Society of Automotive Engineers and are used for classifying oils according to their viscosity. The viscosity describes only one property of oil and says nothing about quality.

ABS	Anti-lock braking system	Safety system that prevents locking of the wheels when driving straight ahead without the influence of lateral forces
DRL	Daytime Running Light	Light, which enhances the visibility of the vehicle during the day but is not focused, and in contrast to low beam does not illuminate the road surface
ETTC	Engine traction torque control	Auxiliary function of the engine control, which prevents rear wheel locking with excessive engine braking effect, by lightly opening the throttle valve
-	KTM MY RIDE	System for wireless communication with appropriate cellphones and headsets for telephony and audio
-	Launch control	Vehicles electronics functions for achieving the best possible acceleration from a standing position
MTC	Motorcycle Traction Control	Auxiliary function of the motor control that reduces engine torque with spinning rear wheel
OBD	On-board diagnosis	Vehicle system, which monitors the specified parameters of the vehicle electronics
-	Quickshifter +	Engine electronics function for shifting up and down without clutch actuation

Art. no.	Article number
ca.	circa
cf.	compare
e.g.	for example
etc.	et cetera
i.a.	inter alia
no.	number
poss.	possibly





30.1 Red symbols

Red symbols indicate an error condition that requires immediate intervention.

	The immobilizer indicator lamp lights up or flashes red – Status or error message of the alarm system.
	The oil pressure warning lamp lights up red – The oil pressure is too low. Stop immediately, taking care not to endanger yourself or other road users in the process, and switch off the engine.





30.2 Yellow and orange symbols

Yellow and orange symbols indicate an error condition that requires prompt intervention. Active driving aids are also represented by yellow or orange symbols.

	Malfunction indicator lamp lights up yellow – The OBD has detected a malfunction in the vehicle electronics. Come safely to a halt, and contact an authorized KTM workshop.
	ABS warning lamp lights up yellow – Status or error messages relating to ABS.
	TC indicator lamp lights up yellow – MTC (📖 p. 112) is not enabled or is currently intervening. The TC indicator lamp also lights up if a malfunction is detected. Contact an authorized KTM workshop. The TC indicator lamp flashes if MTC actively engages or if the Launch Control (📖 p. 52) is activated.
	The cruise control system indicator lamp (optional) lights up yellow – The cruise control system function is switched on, but cruise control is not activated.
	The general warning lamp lights up yellow – A note/warning on operating safety has been detected. This is also shown in the display.

30.3 Green and blue symbols

Green and blue symbols reflect information.

	The turn signal indicator lamp flashes green simultaneously with the turn signal – The turn signal is switched on.
	The idle indicator lamp lights up green – The transmission is in neutral.
	The cruise control system indicator lamp (optional) lights up green – The cruise control system function is switched on and cruise control is activated.
	The high beam indicator lamp lights up blue – The high beam is switched on.

1	
12-V battery	
charging	96
installing	95
removing	94
A	
ABS	78
ABS fuses	
changing	99
ACC1	
front	105
rear	105
ACC2	
front	105
rear	105
Antifreeze	
checking	106
Anti-lock braking system	78
Auxiliary substances	9
B	
Brake discs	
checking	79
Brake fluid	
of front brake, adding	80
of rear brake, adding	83
Brake fluid level	
front brake, checking	79
rear brake, checking	82
Brake lining retainers	
of front brake, checking	81
of rear brake, checking	84
Brake linings	
of front brake, checking	81
of rear brake, checking	84
Brake system	78-84
Brakes	57
Brakes, applying	57
Breakdown	
towing	59
C	
Capacity	
coolant	110-111, 127
Engine oil	115, 127
fuel	60, 128
Chain	
checking	75
cleaning	73
dirt, checking for	72
Chain tension	
adjusting	74
checking	73
Clutch lever	14
basic position, adjusting	45
Combination instrument	22-43
ABS display	28
ABS Mode	40
activation and test	22
Anti-wheelie mode (optional)	38
Audio player	42
Bluetooth®	31
Clock/Date	33
Consumption	32
coolant temperature indicator	27
cruise control indicator	27
day-night mode	22
display	25
Distance	31
DRL	33
Extra functions	36
Favorites	29
fuel level display	27
General Info	30
heated grip (optional)	26
Heated Grips (optional)	36, 39
indicator lamps	23
KTM MY RIDE	41
Language	33
Launch control (optional)	38
menu	29
MTC	39
MTC + MSR (optional)	39
overview	22
Pairing	41
Pressure	32
Quick Selector 1	35
Quick Selector 2	35
quickshifter + (optional)	40
Ride Mode	37, 112
Service	36
Set Favorites	36
Settings	31
shift warning light	28
Shift Light	40
slip adjustment (optional)	113
telephony	43
Temp	32
Throttle response (optional)	113
time	28
TPMS warning	34
Track (optional)	38

TRACK Display (optional)	26	Fork part number	13
trip odometer	28	Free travel of clutch lever	
Trip 1	29	checking	117
Trip 2	30	setting	117
warnings	23, 37	Front rider's seat	
Combination switch	14	mounting	72
overview	14	Front rider's seat	
Coolant		removing	71
draining	108	Front wheel	
Coolant level		installing	86
checking	106	removing	85
checking in the compensating tank	107	Fuel tank filler cap	
Cooling system	106	closing	19
filling/bleeding	109	opening	18
Cover of the headlight mask rack		Fuel, oils, etc.	9
installing	103	Fuse	
removing	102	of individual electrical power consumers,	
Cruise control system		changing	100
operation	15	G	
Customer service	9	Grab handle	20
D		H	
Declarations of conformity	135	Hand brake lever	14
country-specific	135	adjusting the response	45
Diagnostics connector	104	basic position, adjusting	45
E		Handlebar position	44
Emergency OFF switch	17	adjusting	44
Engine		Headlight	
running in	49	daytime running light	94
Engine number	12	range, adjusting	104
Engine oil		setting, checking	103
adding	116	Headlight mask with headlight	
changing	114	mounting	101
Engine oil level		releasing	101
checking	114	Horn button	17
Engine sprocket		I	
checking	75	Ignition lock	18
Engine traction torque control	57	Implied warranty	9
Environment	8	Indicator lamps	23
F		Intended use	6
Figures	9	K	
Foot brake lever	21	Key number	12
basic position, adjusting	46	L	
free travel, checking	82	Launch Control (optional)	52
Fork	63	Light switch	15
compression damping, adjusting	63	Loading the vehicle	49
rebound, adjusting	63	Luggage	49
Fork legs			
dust boots, cleaning	69		

M		S	
Main fuse		Safe operation	7
changing	98	Seat lock	19
Manufacturer warranty	9	Service	9
Misuse	6	Service schedule	61-62
Motorcycle		Shift lever	21
cleaning	118	basic position, adjusting	47
lifting with front lifting gear	68	basic position, checking	47
raising with the rear lifting gear	68	Shifting	54
rear from the lifting gear, removing	68	Shock absorber	63
taking off front lifting gear	69	compression damping	64
Motorcycle traction control	112	high-speed compression damping, adjusting	65
MSR	57	low-speed compression damping, adjusting	64
MTC	112	rebound damping, adjusting	66
O		spring preload, adjusting	66
Oil filter		Shock absorber article number	13
changing	114	Side stand	21
Oil screens		Slip adjustment (optional)	113
cleaning	114	Spare parts	9
Owner's Manual	8	Start button	17
P		Starting	51
Parking	58	Steering damper article number	13
Passenger foot pegs	20	Steering lock	18
Passenger seat		Stopping	58
mounting	71	Storage	120-121
removing	70	Switch	
Preparing for use		on the left side of the handlebar	14
advice on preparing for first use	48	on the right side of the handlebar	17
after storage	121	T	
checks and maintenance measures when preparing for use	51	Technical accessories	9
Protective clothing	7	Technical specifications	
Q		capacities	127
Quickshifter + (optional)	53	chassis	128
R		chassis tightening torques	130
Rear hub damping rubber pieces		electrical system	129
checking	90	engine	124-134
Rear sprocket		engine tightening torques	125
checking	75	fork	129
Rear wheel		shock absorber	130
installing	88	tires	129
removing	87	Throttle grip	14
Refueling		Tire condition	
fuel	60	checking	91
Riding	54	Tire pressure	
starting off	52	checking	92
starting off with launch control (optional)	53	Tire repair spray	
		using	92
		Tool set	20
		Towing	59
		Transporting	59

Troubleshooting	122-123
Turn signal switch	17
Type label	12
U	
Use definition	6
V	
Vehicle identification number	12
View of vehicle	
front left	10
rear right	11
W	
Winter operation	
checks and maintenance steps	119
Work rules	8



3214759en

05.01.2023

