

690 ENDURO R

ART. NO. 3214564EN



Perform the work described in these setup instructions before the vehicle is delivered to the customer.

Read the setup instructions in their entirety before beginning work.

These setup instructions were written to correspond to the latest state of this model series. We reserve the right to make modifications in the interest of technical advancement without at the same time updating these setup instructions.

We shall not provide a description of general workshop methods. Likewise, safety rules that apply in a workshop are not specified here. It is assumed that the work will be performed by a fully trained mechanic.

All specifications contained herein are non-binding. KTM Sportmotorcycle GmbH specifically reserves the right to modify or delete technical specifications, prices, colors, forms, materials, services, designs, equipment, etc., without prior notice and without specifying reasons, to adapt these to local conditions, as well as to stop production of a particular model without prior notice. KTM accepts no liability for delivery options, deviations from figures and descriptions, misprints, and other errors. The models portrayed partly contain special equipment that does not belong to the regular scope of supply.

© 2022 KTM Sportmotorcycle GmbH, Mattighofen Austria

All rights reserved

Reproduction, even in part, as well as copying of all kinds, is permitted only with the express written permission of the copyright owner.



ISO 9001(12 100 6061)

KTM applies quality assurance processes that lead to the highest possible product quality as defined in the ISO 9001 international quality management standard.

Issued by: TÜV Management Service

REG.NO. 12 100 6061

KTM Sportmotorcycle GmbH
Stallhofnerstraße 3
5230 Mattighofen, Austria

This document is valid for the following models:

690 ENDURO R EU (F9703V8)



1 MEANS OF REPRESENTATION

1.1 Symbols used

The meaning of specific symbols is described below.



Indicates an expected reaction (e.g. of a work step or a function).



Indicates an unexpected reaction (e.g. of a work step or a function).



Indicates a page reference (more information is provided on the specified page).



Indicates information with more details or tips.



Indicates the result of a testing step.



Indicates a voltage measurement.



Indicates a current measurement.



Indicates a resistance measurement.



Indicates the end of an activity including potential rework.

1.2 Formats used

The typographical formats used in this document are explained below.

Proprietary name

Indicates a proprietary name.

Name[®]

Indicates a protected name.

Brand[™]

Indicates a brand available on the open market.

Underlined terms

Refer to technical details of the vehicle or indicate technical terms, which are explained in the glossary.

2.1 Transport mode

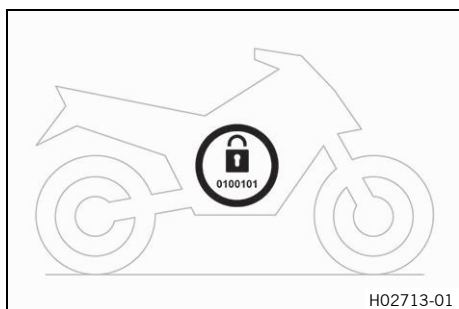

This vehicle was blocked for transport in the software. To operate the vehicle, the vehicle electronics must be enabled. This process is conducted during initial setup in KTM Dealer.net. Enabling ensures that the initial setup in KTM Dealer.net is documented.

Enabling can be performed either temporarily, e.g. for a test ride, or permanently for vehicle handover.

i Info

Make sure that the vehicle is permanently enabled before handing it over to the customer.

2.2 Diagnostics connector

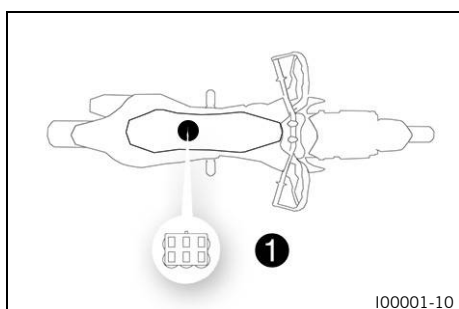

Diagnostics connector ① is located under the engine control unit.

2.3 Unpacking and setting up the vehicle

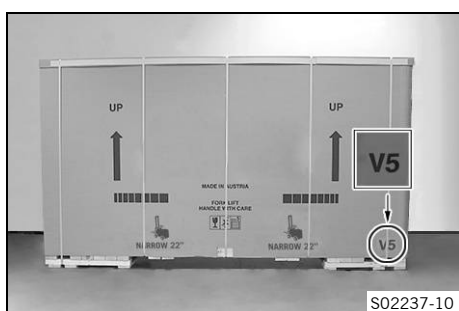

- Remove the straps and the box.



- Remove the adhesive tape in the upper area of the motorcycle.
- Roll down the film at the sides.

i Info

To avoid damaging the motorcycle during unpacking, leave the other films on the vehicle until you have finished work on the vehicle.

- Remove the separate enclosure and unpack it. Check that the separate enclosure is complete using the enclosed packing list.

i Info

The procedure for missing components is described in the Customer Service Manual.

- Check the vehicle for transport damage.

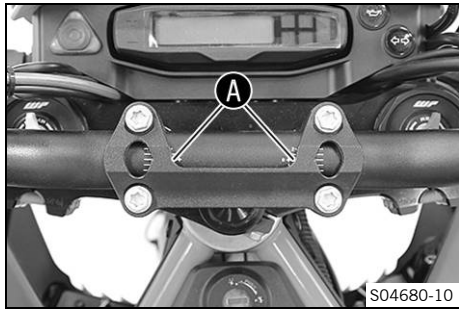

i Info

The procedure in the event of transport damage is described in the Customer Service Manual.

- Remove cable ties and protective film on the handlebar.



Warning

Danger of accidents A repaired handlebar poses a safety risk.

If the handlebar is bent or straightened, the material becomes fatigued. The handlebar may break as a result.

- Change the handlebar if the handlebar is damaged or bent.

- Position the handlebar.

i Info

Make sure the cables and wiring are positioned correctly.

- Position the handlebar clamp. Mount the four screws and tighten evenly.

Guideline

Mount the handlebar clamp as shown in the figure.

Screw, handlebar clamp	M8	20 Nm (14.8 lbf ft)
------------------------	----	---------------------

- ✓ The markings **A** of the handlebar scale are located centrally between the handlebar clamp.

i Info

The handlebar clamp is in the separate enclosure together with the screws.

- Position the controls on the right half of the handlebar.
- Mount the screws, but do not tighten them yet.





- Position the controls on the left handlebar half.
- Mount the screws, but do not tighten them yet.

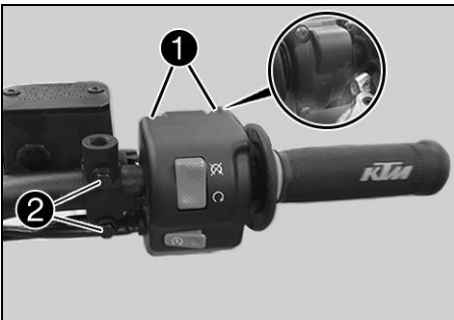

- Position all controls in their exact positions on the handlebar.
- Tighten screws **1** and **2**.

Guideline

Screw, throttle grip	M5	3.5 Nm (2.58 lbf ft)
Screw, brake assembly	M6	5 Nm (3.7 lbf ft)

- Check the throttle grip for smooth operation.
- Tighten screws **3** and **4**.

Guideline

Screw, combination switch, left	M5	3.5 Nm (2.58 lbf ft)
Screw, clutch assembly	M6	5 Nm (3.7 lbf ft)

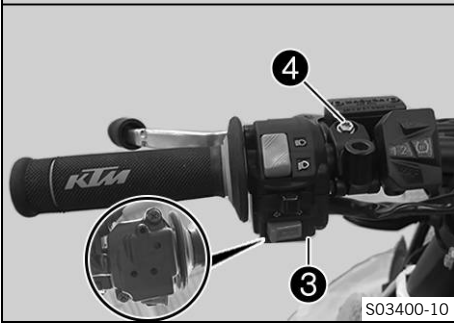

- Assemble the hand guards and mount on both sides.

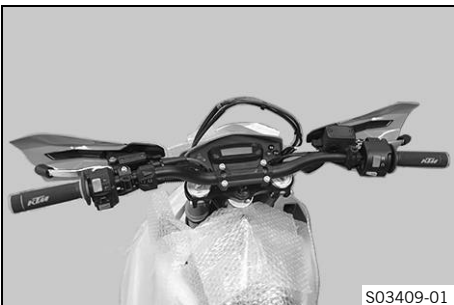

- Mount and tighten the rear mirror adapter and the rear mirror on both sides.



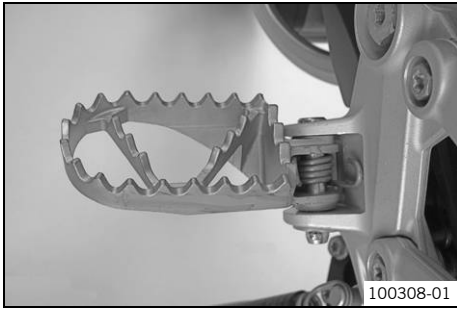

- Mount the footrests with springs and pins. Secure the pins using washers and cotter pins.

Footrest spring plier (58429083000)

- Remove the protective film.
- Carefully loosen and remove the tension belt over the link fork.



Info

An assistant prevents the motorcycle from falling over.

- Carefully loosen and remove the tension belts around the lower triple clamp.

✓ The vehicle is released at the front.

- Together with an assistant, take the vehicle off the pallet.

- Charge the 12-V battery. (📖 p. 10)

Guideline

The 12-V battery must be fully charged before it is handed over to the customer.

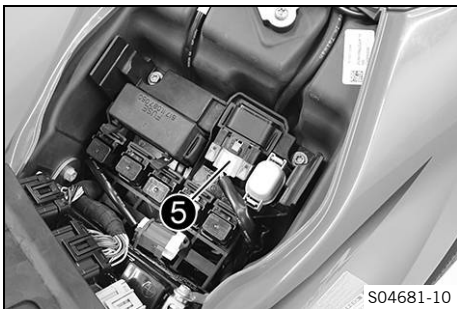

Info

The first charging process may take longer with a new 12-V battery.

- Install the 12-V battery. (📖 p. 11)

- Plug in connector **5** on the starter relay.

- Remove the rear fairing. (📖 p. 13)

- Take off the side cover. (📖 p. 13)

- Remove the rear left side cover. (📖 p. 14)

- Remove the rear right side cover. (📖 p. 14)

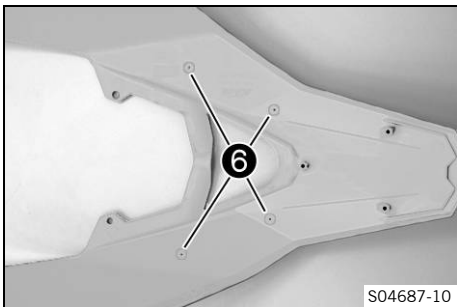

Info

A total of four markings **6** have been added to the underside of the rear fairing and the two side covers.

- Drill the holes for the grab handle in three steps at these points.

Guideline

Bore diameter for the grab handle	14.5 mm (0.571 in)
-----------------------------------	--------------------

- Install the rear left side cover. (📖 p. 15)

- Install the rear right side cover. (📖 p. 15)

- Fit the rear fairing. (📖 p. 16)

- Store tool set **7** in the tool set compartment.

- Mount side cover. (📖 p. 16)



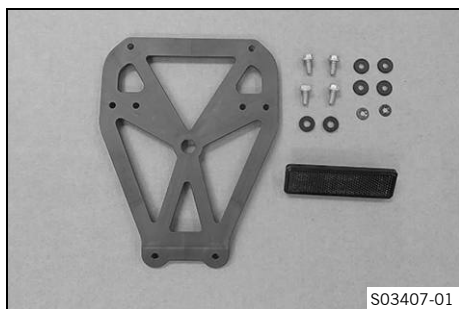

- Mount the reflector.

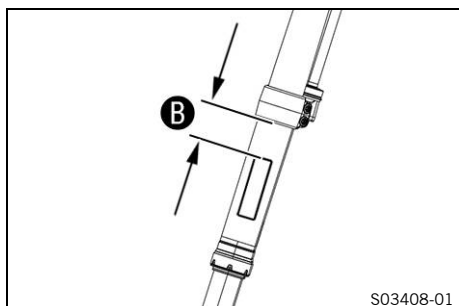

- Mount the reflectors with distance **B** on the fork.
Guideline

Distance B for reflectors	100 mm (3.94 in)
----------------------------------	------------------

Operation as a 2-seater

- Mount rear footrest bracket. (📖 p. 17)

Operation as a 1-seater (only if requested by customer)

Note

Voiding of the government approval for road use and the insurance coverage If the heel protector is fitted instead of the footrest bracket, the vehicle no longer conforms to the homologation.

The vehicle is homologated in the factory as 2-seater.

- Set up the vehicle as standard as a 2-seater.
- If you set up the vehicle as a 1 seater, ensure the change is entered in the registration papers before preparing for use.

- Mount heel protector. (📖 p. 17)
- Refuel. (📖 p. 18)
- Remove the remaining film, padding, the corrugated cardboard, and the other packaging material.
- Prepare the vehicle according to the specifications in **KTM Dealer.net** for handover to the customer.



Info

Transport mode must be deactivated to be able to start the motorcycle.

- Set the kilometers or miles. (📖 p. 20)



3.1 Removing the seat

Preparatory work

- Open the fuel tank filler cap. (📖 p. 12)

Main work

- Pull on loop ❶ and raise the rear of the seat.
- Pull the seat back and lift it off.

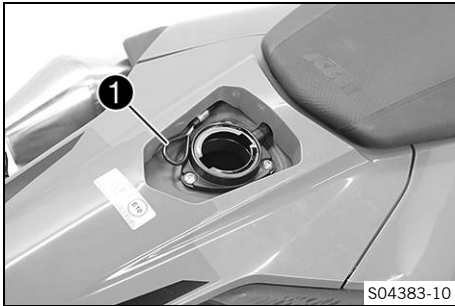

Finishing work

- Close the fuel tank filler cap. (📖 p. 13)

3.2 Mounting the seat



- Hook the seat using holding lugs ❶ on to bushings ❷, lower the seat at the rear and push it forward.
- Push locking pin ❸ into lock housing ❹ and push the back of the seat down until the locking pin locks in place with an audible click.
- Check that the seat is correctly mounted.

3.3 Removing the 12-V battery



Warning

Risk of injury Battery acid and battery gases cause serious chemical burns.

- Keep 12 V batteries out of the reach of children.
- Wear suitable protective clothing and safety glasses.
- Avoid contact with battery acid and battery gases.
- Keep sparks or open flames away from the 12 V battery.
- Only charge 12 V batteries in well-ventilated rooms.
- Rinse the affected area immediately with plenty of water in the event of contact with the skin.
- Rinse eyes with water for at least 15 minutes and consult a doctor immediately if battery acid and battery gases get into the eyes.

Preparatory work

- Open the fuel tank filler cap. (📖 p. 12)
- Remove the seat. (📖 p. 8)

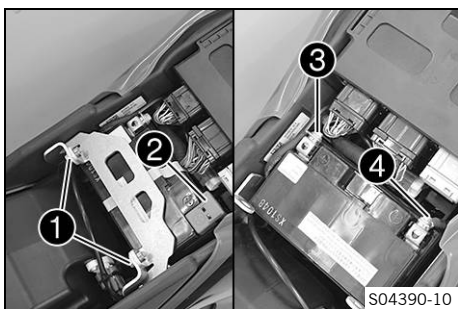

Main work

- Remove screws ①.
- Push the retaining bracket toward the rear and remove it.
- Take off positive terminal cover ②.
- Disconnect negative cable ③ from the 12-V battery.
- Disconnect positive cable ④ from the 12-V battery.
- Lift out the 12-V battery.



Info

Never operate the motorcycle with a discharged 12-V battery or without a 12-V battery. In both cases, electrical components and safety devices can be damaged. The vehicle will therefore no longer be roadworthy.

3.4 Disconnecting the 12-V battery

Preparatory work

- Open the fuel tank filler cap. (📖 p. 12)
- Remove the seat. (📖 p. 8)

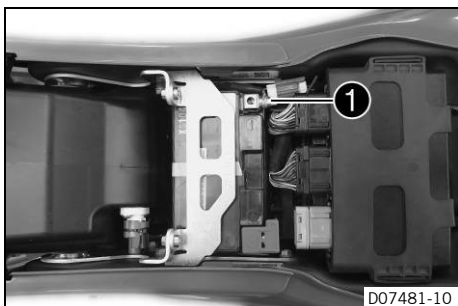

Main work

- Disconnect negative cable ① of the 12-V battery.



Info

Never operate the motorcycle with a discharged 12-V battery or without a 12-V battery. In both cases, electrical components and safety devices can be damaged. The vehicle will therefore no longer be roadworthy.

3.5 Connecting the 12-V battery

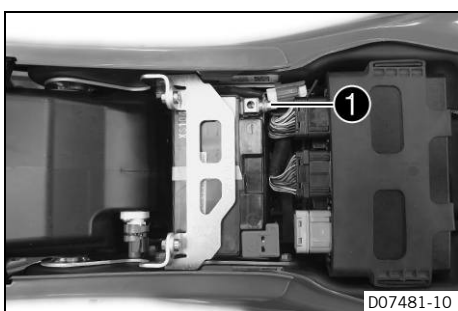

Main work

- Position washer and negative cable ①, and mount and tighten the screw.

Guideline

Screw, battery terminal	M6	4.5 Nm (3.32 lbf ft)
-------------------------	----	-------------------------

Finishing work

- Mount the seat. (📖 p. 8)
- Set the clock. (📖 p. 19)

3.6 Charging the 12-V battery



Warning

Risk of injury Battery acid and battery gases cause serious chemical burns.

- Keep 12 V batteries out of the reach of children.
- Wear suitable protective clothing and safety glasses.
- Avoid contact with battery acid and battery gases.
- Keep sparks or open flames away from the 12 V battery.
- Only charge 12 V batteries in well-ventilated rooms.
- Rinse the affected area immediately with plenty of water in the event of contact with the skin.
- Rinse eyes with water for at least 15 minutes and consult a doctor immediately if battery acid and battery gases get into the eyes.

Note

Danger of damage An incorrectly selected charging mode will damage the 12-V battery.

- Always select a charging mode that is compatible with the type of battery.



Note

Environmental hazard 12 V batteries contain environmentally hazardous materials.

- Do not dispose of 12 V batteries as household waste.
- Dispose of 12 V batteries at a collection point for used batteries.



Note

Environmental hazard Hazardous substances cause environmental damage.

- Dispose of oils, grease, filters, fuel, cleaning agents, brake fluid, etc., correctly and in compliance with the applicable regulations.



Info

Even when there is no load on the 12-V battery, it discharges steadily each day.

The charging level and the method of charging are very important for the service life of the 12-V battery.

Rapid recharging with a high charging current shortens the service life of the battery.

If the charging current, charging voltage, and charging time are exceeded, the 12-V battery will be destroyed.

If the 12-V battery is depleted from starting the vehicle repeatedly, the battery must be charged immediately.

If the 12-V battery is left in a discharged state for an extended period, it will become deeply discharged and sulfating occurs, thus destroying the battery.

The 12-V battery is maintenance-free, i.e. the acid level does not have to be checked.

Preparatory work

- Open the fuel tank filler cap. (📖 p. 12)
- Remove the seat. (📖 p. 8)
- Disconnect the 12-V battery. (📖 p. 9)

Main work

- Connect a battery charger to the 12-V battery. Switch on the battery charger.

EU battery charger **XCharge-professional** (00029095050)

Alternative 1

US battery charger **XCharge-professional**
(00029095051)

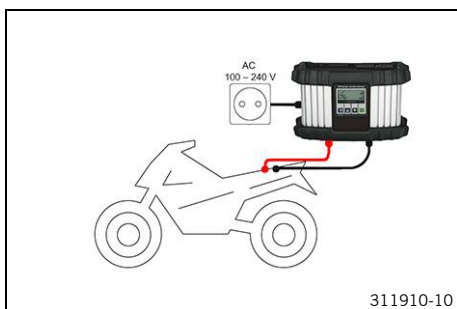

Alternative 2

UK battery charger **XCharge-professional**
(00029095052)

i Info
Follow the charger's instructions exactly.

- Disconnect the battery charger after charging the 12-V battery.

Guideline

The charging current, charging voltage, and charging time must not be exceeded.	
Recharge the 12-V battery regularly when the motorcycle is not being used	3 months

Finishing work

- Connect the 12-V battery. (📖 p. 9)
- Mount the seat. (📖 p. 8)
- Set the clock. (📖 p. 19)

3.7 Installing the 12-V battery



Main work

- Insert the 12-V battery into the battery compartment with the terminals facing to the rear.

12-V battery (YTZ10S)

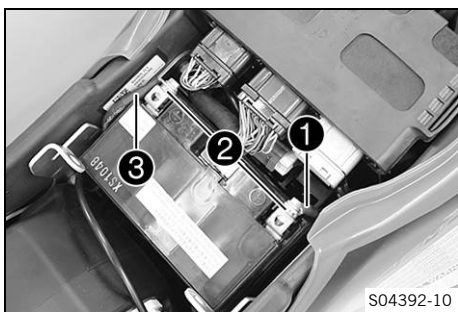

- Position positive cable ① with washer ②.
- Position negative cable ③ with washer ②.
- Mount and tighten the screw.

Guideline

Screw, battery terminal	M6	4.5 Nm (3.32 lbf ft)
-------------------------	----	-------------------------

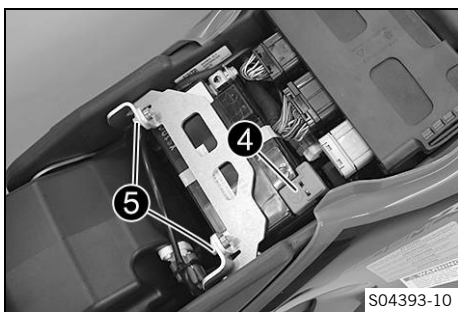

- Position positive terminal cover ④.
- Position retaining bracket and mount and tighten screws ⑤.

Guideline

Remaining screws, chassis	M6	10 Nm (7.4 lbf ft)
---------------------------	----	--------------------

Finishing work

- Mount the seat. (🔧 p. 8)
- Set the clock. (🔧 p. 19)

3.8 Opening the fuel tank filler cap**Danger**

Fire hazard Fuel is highly flammable.

The fuel in the fuel tank expands when warm and can escape if overfilled.

- Do not fuel the vehicle in the vicinity of open flames or lit cigarettes.
- Switch off the engine for refueling.
- Make sure that no fuel is spilled; particularly not on hot parts of the vehicle.
- If any fuel is spilled, wipe it off immediately.
- Observe the specifications for refueling.

**Warning**

Danger of poisoning Fuel is poisonous and a health hazard.

- Avoid skin, eye and clothing contact with fuel.
- Immediately consult a doctor if you swallow fuel.
- Do not inhale fuel vapors.
- In case of skin contact, rinse the affected area with plenty of water.
- Rinse the eyes thoroughly with water, and consult a doctor in case of fuel contact with the eyes.
- Change your clothing in case of fuel spills on them.
- Keep fuels correctly in a suitable canister, and out of the reach of children.

**Note**

Environmental hazard Improper handling of fuel is a danger to the environment.

- Do not allow fuel to enter the groundwater, the soil, or the sewage system.

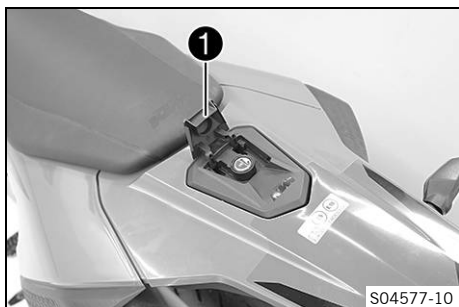

- Lift cover ❶ of fuel tank filler cap and insert the ignition key.
- Turn the ignition key 90° counterclockwise and take off the fuel tank filler cap.

**Info**

The fuel tank filler cap has a fuel tank breather.

3.9 Closing the fuel tank filler cap

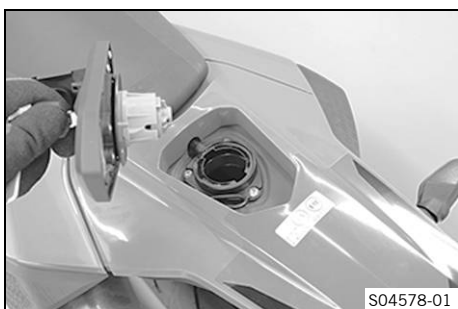

- Put the fuel tank filler cap back on and turn the ignition key 90° clockwise.
- Remove the ignition key and close the cover.

3.10 Removing the rear fairing

Preparatory work

- Open the fuel tank filler cap. (📖 p. 12)
- Remove the seat. (📖 p. 8)

Main work

- Remove screws ❶ with the bushings.
- Remove screws ❷ and take off the grab handle.

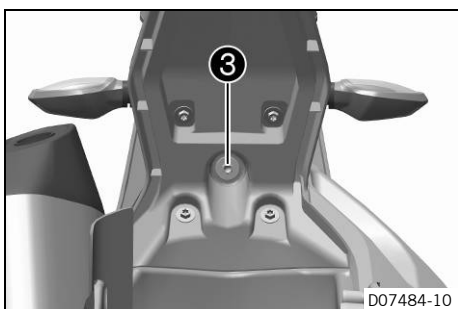
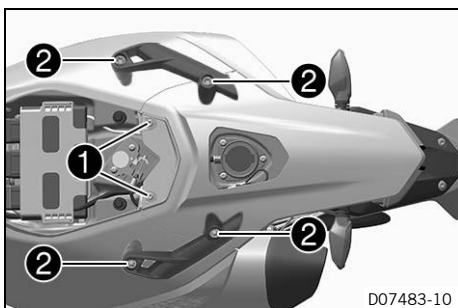

- Remove screw ❸.
- Take off the rear fairing.

Finishing work

- Close the fuel tank filler cap. (📖 p. 13)

3.11 Take off the side cover

Preparatory work

- Open the fuel tank filler cap. (📖 p. 12)
- Remove the seat. (📖 p. 8)

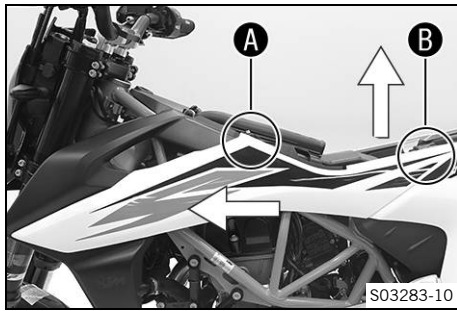

Main work

- Remove the left side cover from the rubber bushing in area **A**.
- Remove the left side cover upwards from the bushing in area **B**.
- Take off the left side cover from the front.
- Repeat these steps on the opposite side.

3.12 Removing the rear left side cover

Preparatory work

- Open the fuel tank filler cap. (📖 p. 12)
- Remove the seat. (📖 p. 8)
- Remove the rear fairing. (📖 p. 13)
- Take off the side cover. (📖 p. 13)

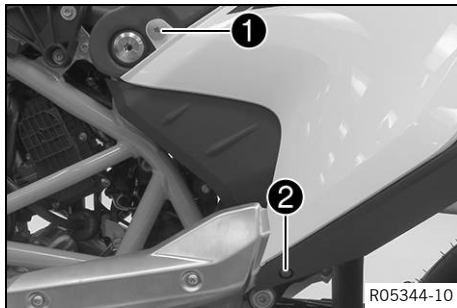

Main work

- Remove screw **1**.
- Remove screw **2**.
- Take off the side cover.

3.13 Removing the rear right side cover

Preparatory work

- Open the fuel tank filler cap. (📖 p. 12)
- Remove the seat. (📖 p. 8)
- Take off the side cover. (📖 p. 13)
- Remove the rear fairing. (📖 p. 13)

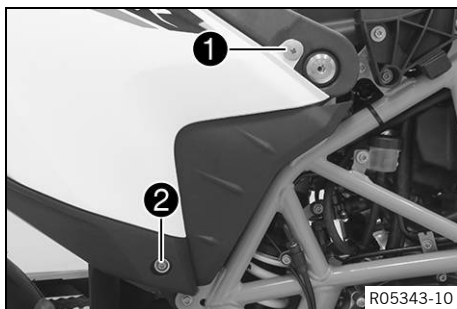

Main work

- Remove screw **1**.
- Remove screw **2** with the bushing.
- Take off the side cover.

3.14 Installing the rear left side cover

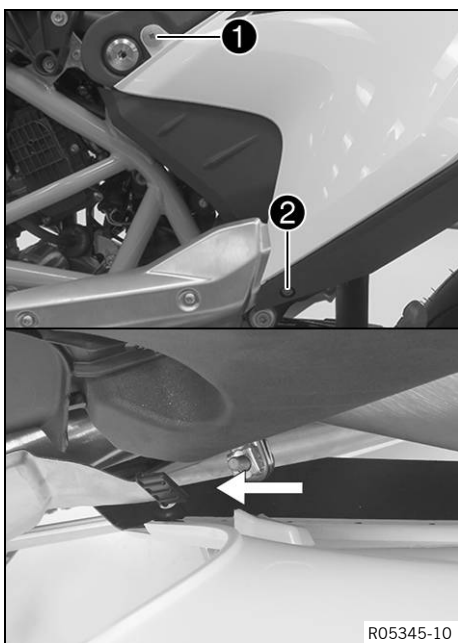

Main work

- Mount the trim.
- ✓ The trim engages in the bracket.
- Mount and tighten screw ①.
- Mount and tighten screw ②.

Guideline

Remaining screws, chassis	M5	5 Nm (3.7 lbf ft)
---------------------------	----	-------------------

Finishing work

- Mount side cover. (📖 p. 16)
- Fit the rear fairing. (📖 p. 16)
- Mount the seat. (📖 p. 8)
- Close the fuel tank filler cap. (📖 p. 13)



3.15 Installing the rear right side cover

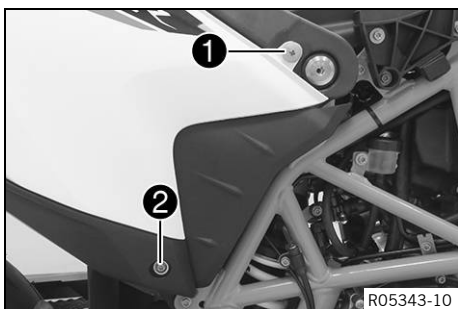

Main work

- Mount side cover.
- Mount and tighten screw ①.
- Mount and tighten screw ② with the bushing.

Guideline

Screw, seat support, center	M6x12	5 Nm (3.7 lbf ft)
-----------------------------	-------	-------------------

Finishing work

- Fit the rear fairing. (📖 p. 16)
- Close the fuel tank filler cap. (📖 p. 13)
- Mount side cover. (📖 p. 16)
- Mount the seat. (📖 p. 8)



3.16 Mounting side cover

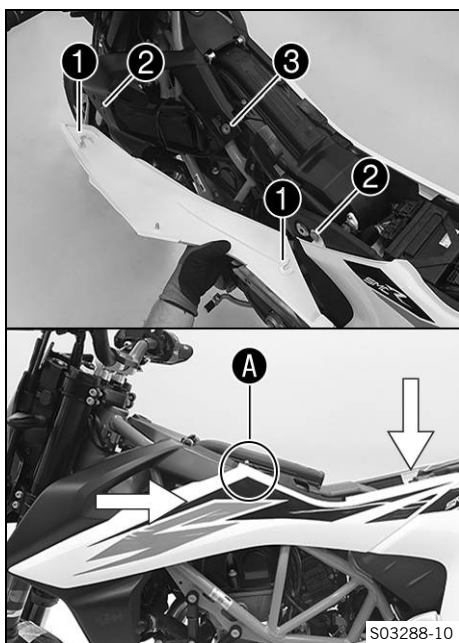

Main work

- Position the left side cover using holding lugs **1** on bushings **2** and push towards the rear and, in the rear section, downward.
- Press the left side cover into the rubber bushing **3** in area **A**.
- Repeat these steps on the opposite side.

Finishing work

- Mount the seat. (📖 p. 8)

3.17 Fitting the rear fairing

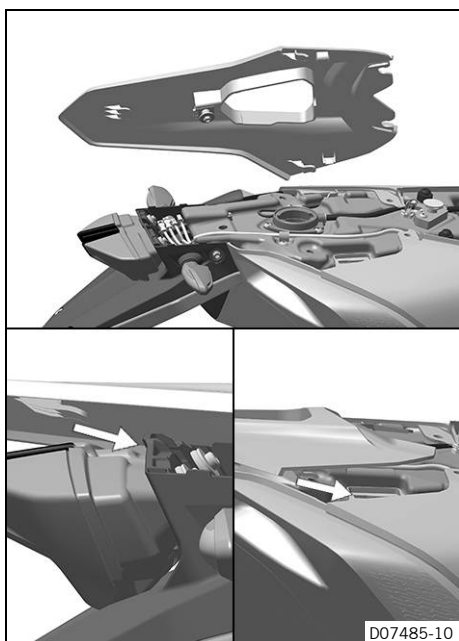

Preparatory work

- Open the fuel tank filler cap. (📖 p. 12)

Main work

- Slip in the rear fairing and position it.

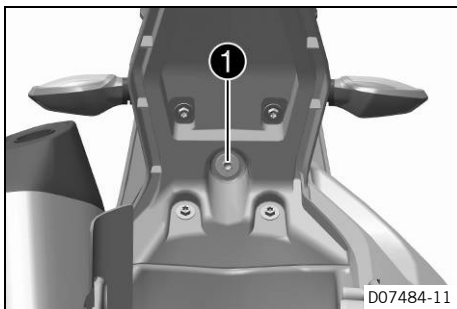

- Mount and tighten screw ①.

Guideline

Screw, tail section	M6x21	10 Nm (7.4 lbf ft)
---------------------	-------	--------------------

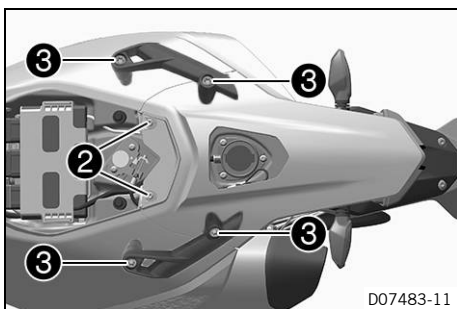

- Mount screws ② with the bushings and tighten.

Guideline

Screw, trim	M5x20	2 Nm (1.5 lbf ft)
-------------	-------	-------------------

- Position the grab handle.
- Mount and tighten screws ③.

Guideline

Screw, grab handle	M8	10 Nm (7.4 lbf ft)
--------------------	----	--------------------

Finishing work

- Mount the seat. (📖 p. 8)
- Close the fuel tank filler cap. (📖 p. 13)

3.18 Mounting rear footrest bracket



Info

The operations are the same for the left and right sides.

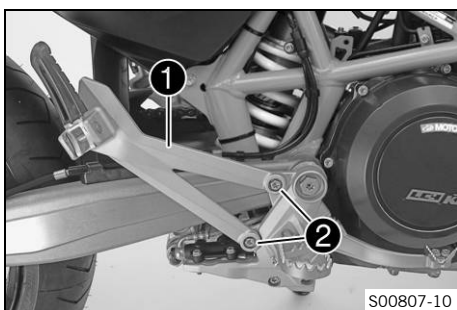

- Position the footrest bracket ①. Mount and tighten screws ②.

Guideline

Screw, rear footrest bracket	M8x16	25 Nm (18.4 lbf ft)
------------------------------	-------	---------------------

3.19 Mounting heel protector



Info

The operations are the same for the left and right sides.

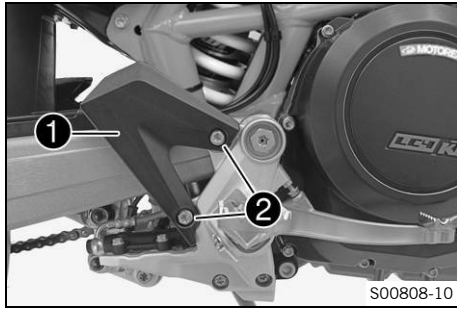

S00808-10

Note

Voiding of the government approval for road use and the insurance coverage If the heel protector is fitted instead of the footrest bracket, the vehicle no longer conforms to the homologation.

The vehicle is homologated in the factory as 2-seater.

- Set up the vehicle as standard as a 2-seater.
- If you set up the vehicle as a 1 seater, ensure the change is entered in the registration papers before preparing for use.

- Position the heel protector ①. Mount and tighten screws ②.

Guideline

Screw, heel protector	M8x12	5 Nm (3.7 lbf ft) Loctite®243™
-----------------------	-------	--

3.20 Installing the engine guard

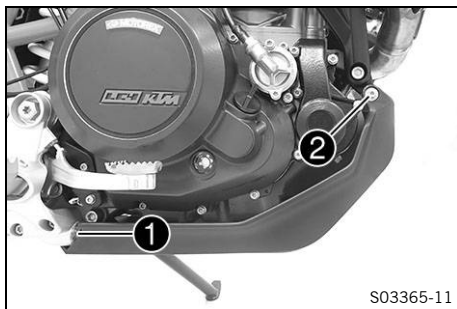

S03365-11

- Slide the engine guard into holders ① at the rear.
- Position the engine guard. Mount and tighten screws ② on both sides.

Guideline

Remaining screws, chassis	M6	10 Nm (7.4 lbf ft)
---------------------------	----	--------------------

3.21 Refueling



Danger

Fire hazard Fuel is highly flammable.

The fuel in the fuel tank expands when warm and can escape if overfilled.

- Do not fuel the vehicle in the vicinity of open flames or lit cigarettes.
- Switch off the engine for refueling.
- Make sure that no fuel is spilled; particularly not on hot parts of the vehicle.
- If any fuel is spilled, wipe it off immediately.
- Observe the specifications for refueling.



Warning

Danger of poisoning Fuel is poisonous and a health hazard.

- Avoid skin, eye and clothing contact with fuel.
- Immediately consult a doctor if you swallow fuel.
- Do not inhale fuel vapors.
- In case of skin contact, rinse the affected area with plenty of water.
- Rinse the eyes thoroughly with water, and consult a doctor in case of fuel contact with the eyes.
- Change your clothing in case of fuel spills on them.

Note

Material damage Inadequate fuel quality causes the fuel filter to quickly become clogged.

In some countries and regions, the available fuel quality and cleanliness may not be sufficient. This will result in problems with the fuel system.

- Refuel only with clean fuel that meets the specified standards.



Note

Environmental hazard Improper handling of fuel is a danger to the environment.

- Do not allow fuel to enter the groundwater, the soil, or the sewage system.

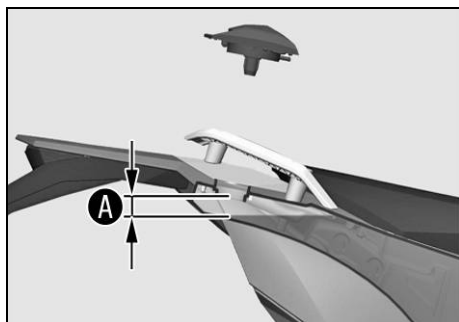

- Switch off the engine.
- Open the fuel tank filler cap. (📖 p. 12)
- Fill the fuel tank with fuel up to level **A**.

Guideline

Dimension A	20 mm (0.79 in)
--------------------	-----------------

Fuel tank capacity, approx.	13.3 l (3.51 US gal)	Super unleaded (ROZ 95) (📖 p. 25)
-----------------------------	----------------------	-----------------------------------

- Close the fuel tank filler cap. (📖 p. 13)

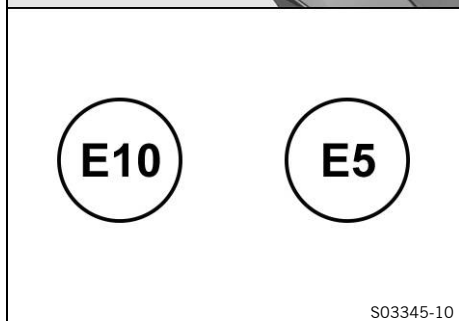

S03345-10

3.22 Setting the clock

Condition

The motorcycle is stationary.

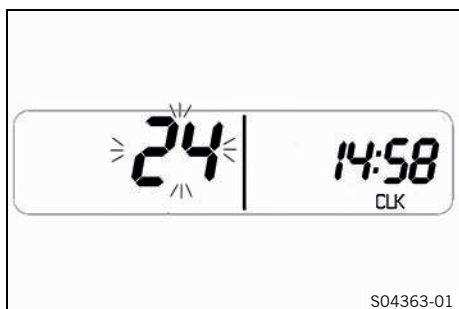

S04363-01

- Press the + or - button until the indicator **CLK** appears in the combination instrument.
- Press and hold the - button for 3-5 seconds.
 - ✓ The combination instrument switches to the clock setting mode.
- Press the - button to select the 24 h display or 12 h display for the clock.
- Confirm the selection using the + button.
 - ✓ The setting is adopted and the combination instrument changes to the next menu item.

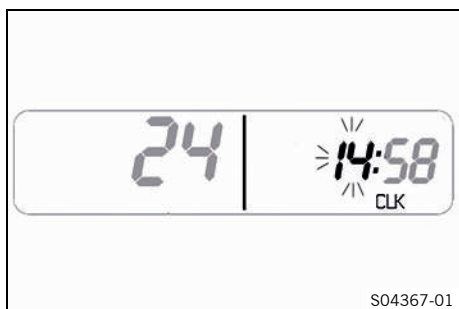

S04367-01

- Press the - button to set the hour.
- Confirm the selection using the + button.
 - ✓ The setting is adopted and the combination instrument changes to the next menu item.
- Press the - button to set the minute.
- Confirm the selection using the + button.
 - ✓ The setting is adopted and the setting mode is closed.

3.23 Setting kilometers or miles

i Info

If the unit is changed, the value is retained and converted accordingly.
Make the setting according to the country.

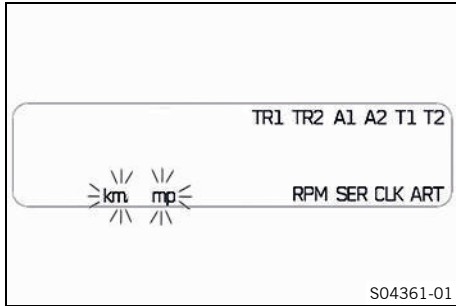

Condition

The motorcycle is stationary.

- Press and hold both buttons for 3 – 5 seconds.
 - ✓ The Setup menu is displayed.
- Press the **+** button repeatedly until **km** or **mp** flashes on the indicator.
- Press the **-** button to change from **km** to **mp** or from **mp** to **km**.
- Press the **+** button.
 - ✓ The settings are adopted and the setup menu is closed.

4.1 chassis tightening torques

Screw, chain guard	EJOT	1.5 Nm (1.11 lbf ft)
Screw, combination instrument	EJOT	1 Nm (0.7 lbf ft)
Screw, combination switch	EJOT PT® K50x18 T20	2 Nm (1.5 lbf ft)
Screw, radiator guard	EJOT PT K50x14 T20	2 Nm (1.5 lbf ft)
Screw, side cover on spoiler	EJOT	1 Nm (0.7 lbf ft)
Screw, side stand sensor	EJOT	1 Nm (0.7 lbf ft)
Screw, tail light	EJOT PT® K45x17-Z	1.5 Nm (1.11 lbf ft)
Fitting, side stand sensor	M4	2 Nm (1.5 lbf ft)
Spoke nipple, front wheel	M4.5	4 Nm (3 lbf ft)
Remaining nuts, chassis	M5	5 Nm (3.7 lbf ft)
Remaining screws, chassis	M5	5 Nm (3.7 lbf ft)
Screw, brake line holder on link fork	M5	5 Nm (3.7 lbf ft)
Screw, cable on starter motor	M5	3 Nm (2.2 lbf ft)
Screw, combination switch, left	M5	3.5 Nm (2.58 lbf ft)
Screw, electrical holder	M5	3 Nm (2.2 lbf ft)
Screw, exhaust heat shield	M5	8 Nm (5.9 lbf ft)
		Loctite®243™
Screw, foot brake lever stub	M5	6 Nm (4.4 lbf ft)
		Loctite®243™
Screw, fuel hose clamp on fuel tank	M5	5 Nm (3.7 lbf ft)
Screw, fuel level sensor	M5	3 Nm (2.2 lbf ft)
Screw, fuel pump	M5	4 Nm (3 lbf ft)
Screw, fuel tank closure flange	M5	2.5 Nm (1.84 lbf ft)
Screw, headlight mask	M5	2 Nm (1.5 lbf ft)
Screw, pressure regulator	M5	4 Nm (3 lbf ft)
Screw, radiator fan cover	M5	3.2 Nm (2.36 lbf ft)
Screw, radiator guard	M5	3.5 Nm (2.58 lbf ft)
Screw, seat lock cable	M5	3 Nm (2.2 lbf ft)
Screw, side cover, fuel tank, left	M5x20	2 Nm (1.5 lbf ft)
Screw, throttle grip	M5	3.5 Nm (2.58 lbf ft)
Screw, trim	M5x12	3.5 Nm (2.58 lbf ft)
Spoke nipple, rear wheel	M5	4 Nm (3 lbf ft)
Remaining nuts, chassis	M6	10 Nm (7.4 lbf ft)
Remaining screws on fuel tank	M6	5 Nm (3.7 lbf ft)
Remaining screws, chassis	M6	10 Nm (7.4 lbf ft)
Screw connection, foot brake cylinder	M6	10 Nm (7.4 lbf ft)
Screw, ABS control unit	M6	5 Nm (3.7 lbf ft)
Screw, ABS module retaining bracket on frame	M6	10 Nm (7.4 lbf ft)
Screw, air filter box, on frame	M6	6 Nm (4.4 lbf ft)
Screw, ball joint of push rod on foot brake cylinder	M6	10 Nm (7.4 lbf ft)
		Loctite®243™

4 TECHNICAL DATA

Screw, battery cable to starter motor	M6	6 Nm (4.4 lbf ft)	
Screw, battery terminal	M6	4.5 Nm (3.32 lbf ft)	
Screw, brake assembly	M6	5 Nm (3.7 lbf ft)	
Screw, brake fluid reservoir for rear brake	M6	5 Nm (3.7 lbf ft)	
Screw, brake line holder on frame	M6x12	6 Nm (4.4 lbf ft)	Loctite®243™
Screw, chain guard	M6	2 Nm (1.5 lbf ft)	Loctite®243™
Screw, chain guide	M6	10 Nm (7.4 lbf ft)	
Screw, chain sliding guard	M6	10 Nm (7.4 lbf ft)	Loctite®243™
Screw, clutch assembly	M6	5 Nm (3.7 lbf ft)	
Screw, electrical holder in fuel tank	M6	2 Nm (1.5 lbf ft)	
Screw, electrical holder under 12-V battery	M6	10 Nm (7.4 lbf ft)	
Screw, front brake disc	M6	14 Nm (10.3 lbf ft)	Loctite®243™
Screw, front left trim	M6x12	5 Nm (3.7 lbf ft)	
Screw, front trim	M6x14	5 Nm (3.7 lbf ft)	
Screw, ignition lock	M6	10 Nm (7.4 lbf ft)	Loctite®243™
Screw, license plate holder, bottom	M6	8 Nm (5.9 lbf ft)	
Screw, license plate holder, bottom	M6x14	5 Nm (3.7 lbf ft)	
Screw, license plate holder, top	M6	8 Nm (5.9 lbf ft)	
Screw, magnetic holder on side stand	M6	6 Nm (4.4 lbf ft)	Loctite®243™
Screw, main silencer clamp	M6	10 Nm (7.4 lbf ft)	Copper paste
Screw, radiator bleeding	M6	8 Nm (5.9 lbf ft)	
Screw, radiator bracket, bottom	M6	8 Nm (5.9 lbf ft)	
Screw, radiator bracket, top	M6	10 Nm (7.4 lbf ft)	
Screw, rear brake disc	M6	14 Nm (10.3 lbf ft)	Loctite®243™
Screw, SAS valve	M6	4 Nm (3 lbf ft)	
Screw, seat lock	M6	5 Nm (3.7 lbf ft)	
Screw, seat support, center	M6x12	5 Nm (3.7 lbf ft)	
Screw, seat support, front	M6x14	5 Nm (3.7 lbf ft)	
Screw, side cover	M6	5 Nm (3.7 lbf ft)	
Screw, tail section	M6x21	10 Nm (7.4 lbf ft)	
Screw, trim	M6x12	3 Nm (2.2 lbf ft)	
Screw, upper part of the air filter box	M6	2 Nm (1.5 lbf ft)	
Screw, voltage regulator	M6	8 Nm (5.9 lbf ft)	
Screw, wheel speed sensor	M6	6 Nm (4.4 lbf ft)	

Nut, manifold on cylinder head	M8	Tighten the nuts evenly. The plate should not be bent. Copper paste
Nut, rear sprocket screw	M8	35 Nm (25.8 lbf ft) Loctite®2701™
Remaining nuts, chassis	M8	25 Nm (18.4 lbf ft)
Remaining screws, chassis	M8	25 Nm (18.4 lbf ft)
Screw, bottom triple clamp	M8	12 Nm (8.9 lbf ft)
Screw, chain sliding piece	M8	15 Nm (11.1 lbf ft)
Screw, connection lever on frame	M8	30 Nm (22.1 lbf ft) Loctite®243™
Screw, engine sprocket cover	M8	15 Nm (11.1 lbf ft)
Screw, foot brake lever	M8	25 Nm (18.4 lbf ft) Loctite®243™
Screw, fork stub	M8	15 Nm (11.1 lbf ft)
Screw, front brake caliper	M8	25 Nm (18.4 lbf ft) Loctite®243™
Screw, front footrest bracket	M8	25 Nm (18.4 lbf ft)
Screw, fuel tank bracket	M8	15 Nm (11.1 lbf ft)
Screw, fuel tank, bottom	M8	25 Nm (18.4 lbf ft) Loctite®243™
Screw, fuel tank, top	M8	25 Nm (18.4 lbf ft) Loctite®243™
Screw, grab handle	M8	10 Nm (7.4 lbf ft)
Screw, handlebar clamp	M8	20 Nm (14.8 lbf ft)
Screw, heel protector	M8x12	5 Nm (3.7 lbf ft) Loctite®243™
Screw, main silencer holder	M8	25 Nm (18.4 lbf ft)
Screw, main silencer holder on fuel tank	M8	25 Nm (18.4 lbf ft)
Screw, rear footrest bracket	M8x16	25 Nm (18.4 lbf ft)
Screw, side stand bracket	M8	25 Nm (18.4 lbf ft) Loctite®243™
Screw, spring holder plate on side stand bracket	M8	25 Nm (18.4 lbf ft) Loctite®243™
Screw, steering stem	M8	20 Nm (14.8 lbf ft)
Screw, top triple clamp	M8	17 Nm (12.5 lbf ft)
Engine carrying screw	M10	45 Nm (33.2 lbf ft) Loctite®243™
Remaining nuts, chassis	M10	45 Nm (33.2 lbf ft)
Remaining screws, chassis	M10	45 Nm (33.2 lbf ft)
Screw, bottom shock absorber	M10	45 Nm (33.2 lbf ft) Loctite®243™
Screw, engine bearer on frame	M10	45 Nm (33.2 lbf ft)
Screw, handlebar support	M10	45 Nm (33.2 lbf ft) Loctite®243™
Screw, side stand	M10	35 Nm (25.8 lbf ft) Loctite®243™

4 TECHNICAL DATA

Screw, top shock absorber	M10	45 Nm (33.2 lbf ft) Loctite®243™
Banjo bolt, brake line	M10x1	25 Nm (18.4 lbf ft)
Lambda sensor	M12x1.25	25 Nm (18.4 lbf ft) Copper paste
Screw, swingarm pivot	M12x1.5	80 Nm (59 lbf ft)
Nut, angle lever to link fork	M14x1.5	100 Nm (73.8 lbf ft)
Nut, linkage lever to rocker arm	M14x1.5	100 Nm (73.8 lbf ft)
Screw, radiator temperature sensor	M18	20 Nm (14.8 lbf ft)
Screw, bottom steering head	M20x1.5	60 Nm (44.3 lbf ft) Loctite®243™
Screw, top steering head	M20x1.5	12 Nm (8.9 lbf ft)
Screw, front wheel spindle	M24x1.5	45 Nm (33.2 lbf ft)
Nut, rear wheel spindle	M25x1.5	90 Nm (66.4 lbf ft)

Super unleaded (ROZ 95)

Standard/classification

- DIN EN 228 (ROZ 95)

Guideline

- Only use super unleaded fuel that matches or is equivalent to the specified standard.
- Fuel with an ethanol content of up to 10% (E10 fuel) is safe to use.



Info

Do **not** use fuel containing methanol (e.g., M15, M85, M100) or more than 10% ethanol (e.g., E15, E25, E85, E100).



3214564en

03/2022

